

Project Name:	Approval:
Location:	Date:
Engineer:	Construction:
Submitted to:	Unit #:
Submitted by:	Drawing #:
Reference:	

MODEL COMPATIBILITY:

Part Number	Compatible Indoor Unit Models
BRP9A71	FXFA, FXTA ^{1,2} , FTA ^{1,2}
BRP9A72	FXTA ^{1,2} , FTA ^{1,2}
BRP9A73	FXMA, FXSA, FBA

Note 1: FXTA (FTA) units have built-in contacts for ventilation alarm, however an adapter can be used if more contacts are required.
 Note 2: BRP9A72 can be used if a longer harness is required for mounting external to the unit.

Installation Plate/Mounting Kit

Install Kit	Compatible Indoor Unit Models
KRP4A93	FXTA, FTA
KRP4A98	FXMA, FXSA, FBA
KRP1H98A	FXFA

SPECIFICATIONS:

Model	BRP9A71, BRP9A72, BRP9A73
Description	Ventilation and Alarm Adapter PCB
PCB Weight	1.4oz (40g)
Wiring Length	KRP9A71 – 59in (1.5m) KRP9A72 – 94in (2.4m) KRP9A73 – 23in (0.6m)
Alarm Contact Rating	1.2 A at 24VAC
PCB Dimensions	3.7" x 2.3" (94mm x 58mm)
Indoor Unit Connection	X40A
Maximum Connections	1 Indoor Unit

PRODUCT IMAGE:



FEATURES:

- Adapter PCB is field installed in the indoor unit to add two relay contacts for alarm or ventilation control
- Included harness plugs directly to indoor unit PCB
- Alarm and ventilation contacts close simultaneously when a refrigerant leak is detected by the refrigerant sensor, and an error code is displayed: A0-17 or A0-19. Contacts will also close when the refrigerant leak detection sensor fault (CH-11) has been detected.
- Contacts open when leak detection errors (A0-17, A0-19) are cleared, and/or the sensor fault (CH-11) is cleared.

Submittal Data Sheet

BRP9A7X – Ventilation and Alarm Adapter

Project Name: _____	Approval: _____
Location: _____	Date: _____
Engineer: _____	Construction: _____
Submitted to: _____	Unit #: _____
Submitted by: _____	Drawing #: _____
Reference: _____	

Items	Adapter PCB	Wire Ties	PCB Support	Relay Harness	Wire Sticker	Install Manual
Quantity	1	3	4	1	2	1
Image						

DIMENSIONS:

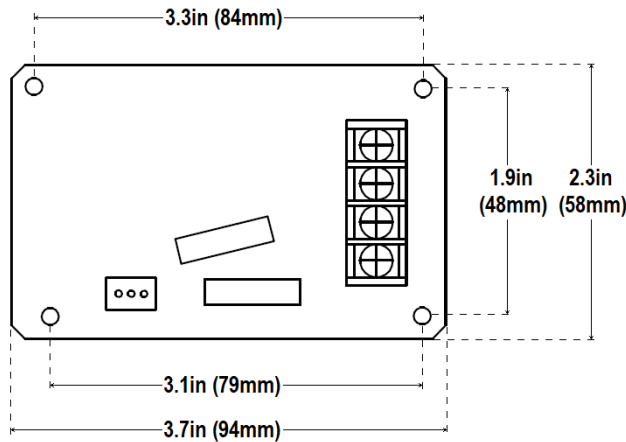

WIRING DIAGRAM:

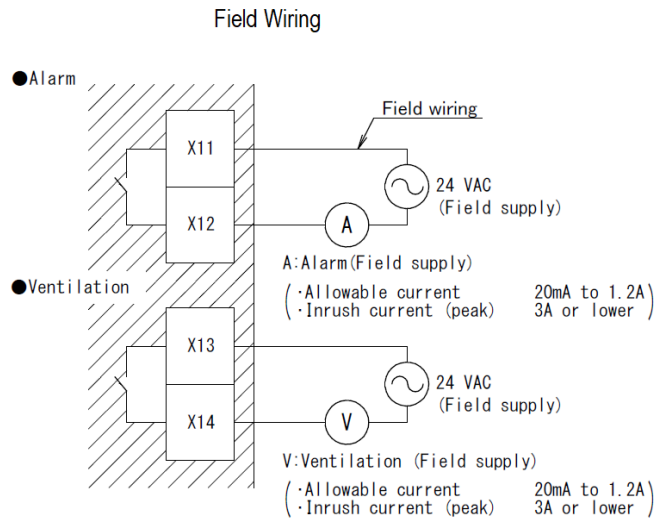
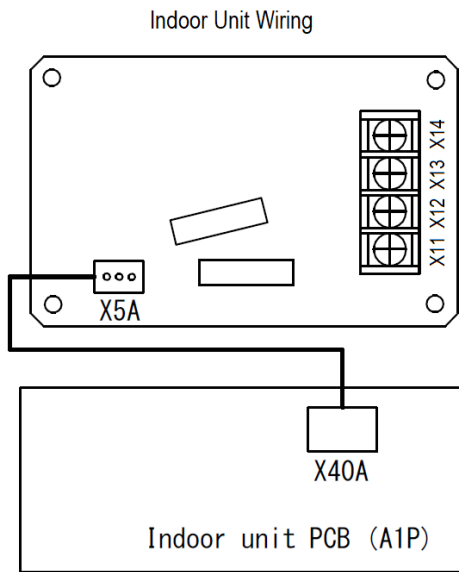

Project Name:	_____	Approval:	_____
Location:	_____	Date:	_____
Engineer:	_____	Construction:	_____
Submitted to:	_____	Unit #:	_____
Submitted by:	_____	Drawing #:	_____
Reference:	_____		

MOUNTING EXAMPLE:

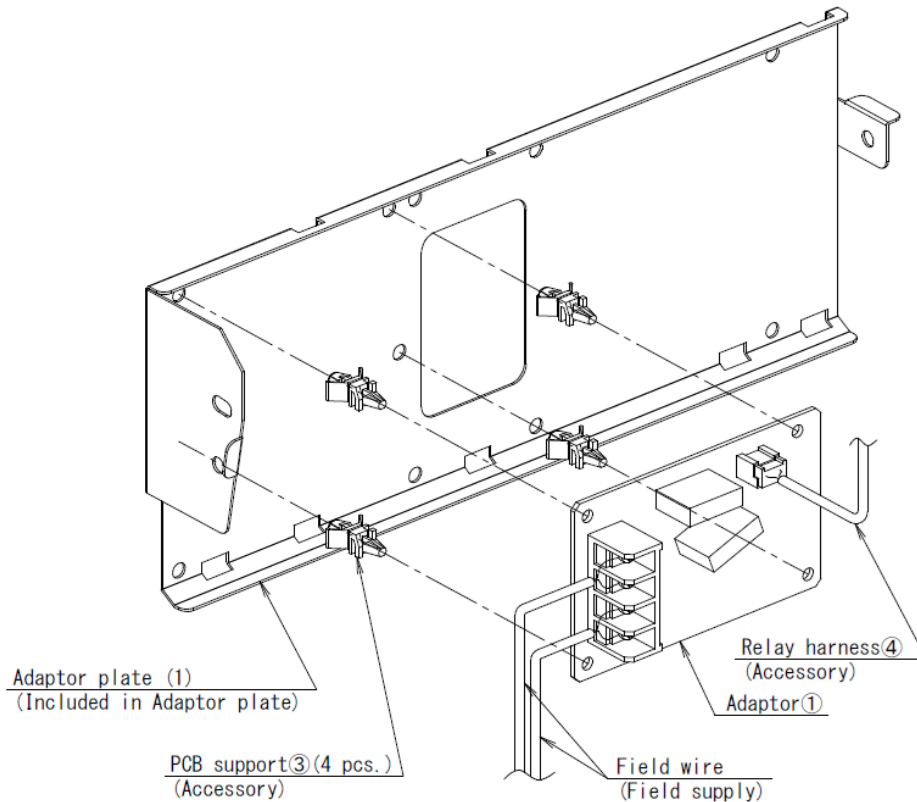

DOCUMENTATION:

Documentation available on www.daikincity.com and/or www.daikincomfort.com:

- Submittal
- Installation Manual