



## Submittal Data Sheet

7.5 Ton Light Commercial Air Handler 460V 3PH R32

DAQ09034

### STANDARD FEATURES

- TXV Control; Units have two (2) thermal expansion valves • DAQ units feature two 5-speed direct-drive motors • Copper tube/aluminum fin coils • AHRI Certified; ETL Listed • R-32 leak mitigation system

### CABINET FEATURES

- Heavy-gauge, reinforced, galvanized-steel cabinet • Fully insulated with fiberglass blanket • Horizontal and vertical condensate pans • Built-in filter rack (2" filter included) • Entry on top of panel for both low and high voltage • Removable access panels make servicing of unit faster and easier





## Submittal Data Sheet

7.5 Ton Light Commercial Air Handler 460V 3PH R32

DAQ09034

### PERFORMANCE

Product Model No.	DAQ09034	Product Model Name:	7.5 Ton Light Commercial Air Handler 460V 3PH R32
Type:	Light Commercial Air Handler	Cooling Capacity (Nominal) (Btu/hr):	90,000

### PRODUCT DETAILS

Dimensions (HxWxD) (in):	24.1875 x 60.46875 x 48.09375	Suction Valve Connection Size (inch):	1-1/8
Net Weight (lb):	430	Liquid Valve Connection Size (inch):	5/8
Gross Weight (lb):	399	Condensate Connection (inch):	3/4

## Submittal Data Sheet

7.5 Ton Light Commercial Air Handler 460V 3PH R32

DAQ09034

## DIMENSIONAL DRAWING

### DIMENSIONS

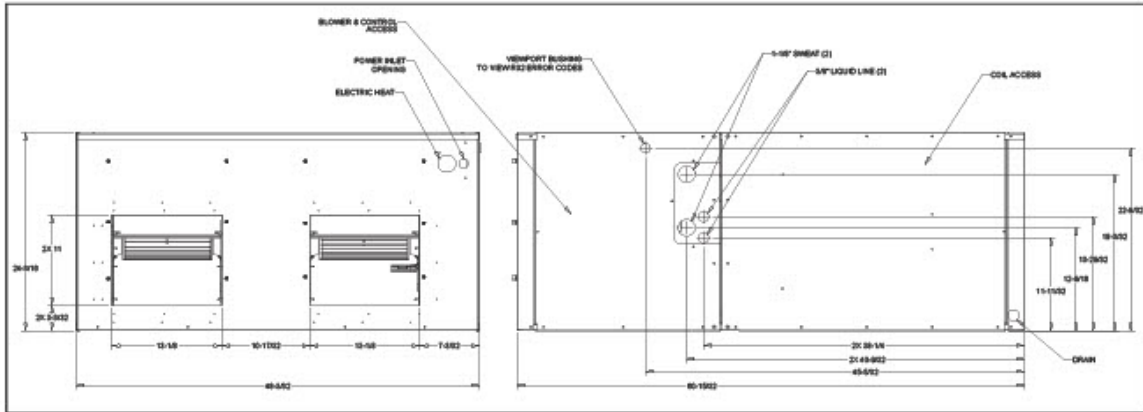

### DUCT CONNECTION SIZING WITHOUT ELECTRIC HEATERS

#### MINIMUM SUPPLY AND RETURN DUCT DIMENSIONS

##### DIMENSIONAL DATA FOR ELECTRIC HEATER KITS

- 15, 20, & 30 kW Heater Kits
- Supply opening is 13 3/4" x 40 3/4"

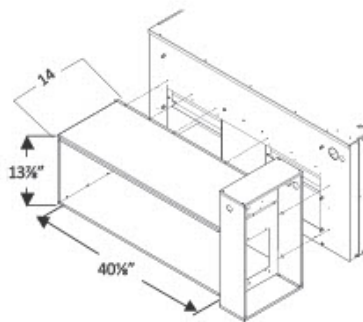

SUPPLY DUCT		RETURN DUCT	
A	B	C	D
13 3/4"	40"	24"	48"

