



Submittal Data Sheet

10 Ton Light Commercial Air Handler 208/230V 3PH R32

DAQ12033

STANDARD FEATURES

- TXV Control; Units have two (2) thermal expansion valves • DAQ units feature two 5-speed direct-drive motors • Copper tube/aluminum fin coils • AHRI Certified; ETL Listed • R-32 leak mitigation system

CABINET FEATURES

- Heavy-gauge, reinforced, galvanized-steel cabinet • Fully insulated with fiberglass blanket • Horizontal and vertical condensate pans • Built-in filter rack (2" filter included) • Entry on top of panel for both low and high voltage • Removable access panels make servicing of unit faster and easier





Submittal Data Sheet

10 Ton Light Commercial Air Handler 208/230V 3PH R32

DAQ12033

PERFORMANCE

Product Model No.	DAQ12033	Product Model Name:	10 Ton Light Commercial Air Handler 208/230V 3PH R32
Type:	Light Commercial Air Handler	Cooling Capacity (Nominal) (Btu/hr):	120,000

PRODUCT DETAILS

Dimensions (HxWxD) (in):	24.1875 x 60.46875 x 48.09375	Suction Valve Connection Size (inch):	1-1/8
Net Weight (lb):	430	Liquid Valve Connection Size (inch):	5/8
Gross Weight (lb):	391	Condensate Connection (inch):	3/4

Submittal Data Sheet

10 Ton Light Commercial Air Handler 208/230V 3PH R32

DAQ12033

DIMENSIONAL DRAWING

DIMENSIONS

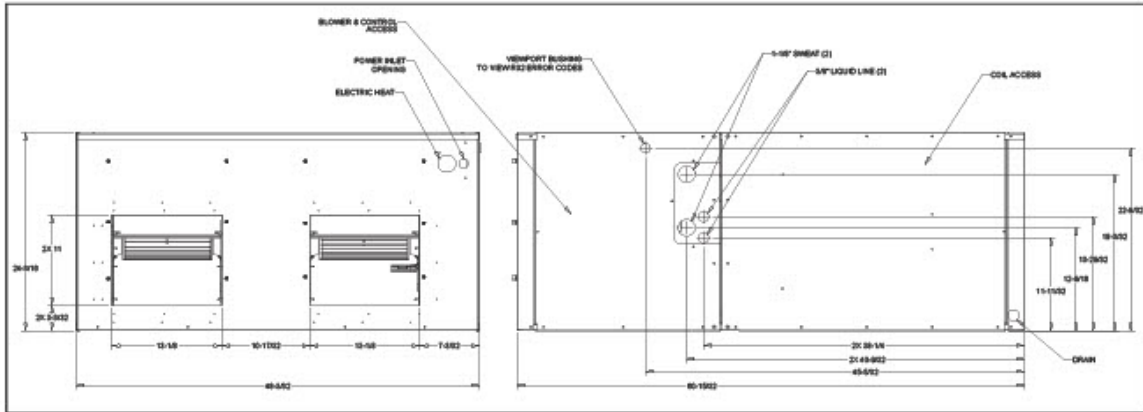

DUCT CONNECTION SIZING WITHOUT ELECTRIC HEATERS

MINIMUM SUPPLY AND RETURN DUCT DIMENSIONS

DIMENSIONAL DATA FOR ELECTRIC HEATER KITS

- 15, 20, & 30 kW Heater Kits
- Supply opening is 13 $\frac{3}{4}$ " x 40 $\frac{3}{4}$ "

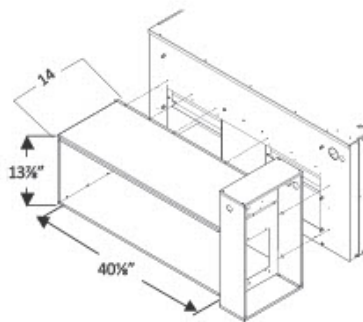

SUPPLY DUCT		RETURN DUCT	
A	B	C	D
13 $\frac{3}{4}$ "	40"	24"	48"

