



Submittal Data Sheet

10 Ton Light Commercial Air Handler 460V 3PH R32

DAQ12034

STANDARD FEATURES

- TXV Control; Units have two (2) thermal expansion valves • DAQ units feature two 5-speed direct-drive motors • Copper tube/aluminum fin coils • AHRI Certified; ETL Listed • R-32 leak mitigation system

CABINET FEATURES

- Heavy-gauge, reinforced, galvanized-steel cabinet • Fully insulated with fiberglass blanket • Horizontal and vertical condensate pans • Built-in filter rack (2" filter included) • Entry on top of panel for both low and high voltage • Removable access panels make servicing of unit faster and easier





Submittal Data Sheet

10 Ton Light Commercial Air Handler 460V 3PH R32

DAQ12034

PERFORMANCE

Product Model No.	DAQ12034	Product Model Name:	10 Ton Light Commercial Air Handler 460V 3PH R32
Type:	Light Commercial Air Handler	Cooling Capacity (Nominal) (Btu/hr):	120,000

PRODUCT DETAILS

Dimensions (HxWxD) (in):	24.1875 x 60.46875 x 48.09375	Suction Valve Connection Size (inch):	1-1/8
Net Weight (lb):	430	Liquid Valve Connection Size (inch):	5/8
Gross Weight (lb):	399	Condensate Connection (inch):	3/4

Submittal Data Sheet

10 Ton Light Commercial Air Handler 460V 3PH R32

DAQ12034

DIMENSIONAL DRAWING

DIMENSIONS

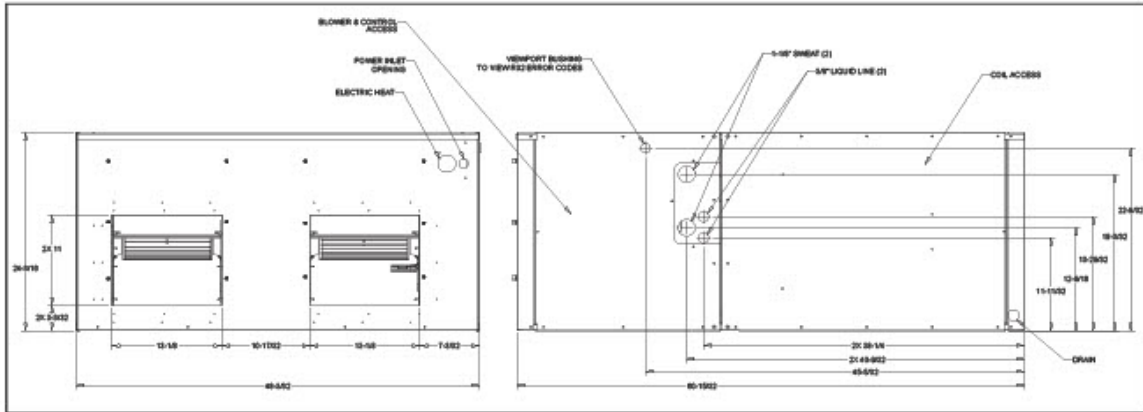

DUCT CONNECTION SIZING WITHOUT ELECTRIC HEATERS

MINIMUM SUPPLY AND RETURN DUCT DIMENSIONS

DIMENSIONAL DATA FOR ELECTRIC HEATER KITS

- 15, 20, & 30 kW Heater Kits
- Supply opening is 13 3/4" x 40 3/4"

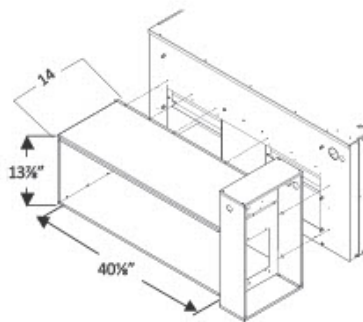

SUPPLY DUCT		RETURN DUCT	
A	B	C	D
13 3/4"	40"	24"	48"

