



SiUS331708EC

**R-410A**

# Service Manual

**VRV**



**RXSQ24/36/48/60TAVJU(A)  
RXSQ24/36/48/60TBVJUA**

**Heat Pump 60 Hz**

<b>Introduction .....</b>	<b>1</b>
1. Safety Cautions.....	2
1.1 Warnings and Cautions Regarding Safety of Workers.....	2
1.2 Warnings and Cautions Regarding Safety of Users.....	4
2. Icons Used .....	7
3. Revision History .....	8
<b>Part 1 General Information .....</b>	<b>9</b>
1. Model Names and Power Supply.....	10
1.1 Outdoor Unit.....	10
1.2 Indoor Unit.....	10
1.3 Air Treatment Equipment .....	11
2. External Appearance.....	12
2.1 Outdoor Unit.....	12
2.2 Indoor Unit.....	12
2.3 Air Treatment Equipment .....	13
3. Capacity Range.....	14
3.1 Connection Ratio.....	14
3.2 Outdoor Unit Combinations .....	14
4. Specifications .....	15
<b>Part 2 Refrigerant Circuit.....</b>	<b>21</b>
1. Refrigerant Circuit (Piping Diagrams) .....	22
1.1 Outdoor Unit.....	22
1.2 Indoor Unit.....	31
1.3 Outdoor-Air Processing Unit.....	34
2. Functional Parts Layout .....	35
2.1 RXSQ24/36TAVJU .....	35
2.2 RXSQ24/36TAVJUA, RXSQ24/36TBVJUA .....	37
2.3 RXSQ48TAVJU .....	39
2.4 RXSQ48TAVJUA, RXSQ48TBVJUA .....	41
2.5 RXSQ60TAVJU.....	43
2.6 RXSQ60TAVJUA, RXSQ60TBVJUA .....	45
<b>Part 3 Remote Controller .....</b>	<b>47</b>
1. Applicable Models .....	48
2. Names and Functions .....	49
2.1 BRC1E73 .....	49
2.2 BRC1H71W.....	52
2.3 Wireless Remote Controller .....	60
3. Main/Sub Setting.....	61
3.1 BRC1E73 .....	61
3.2 BRC1H71W.....	63
3.3 When Wireless Remote Controller is Used Together.....	65

4. Address Setting for Wireless Remote Controller.....	66
5. Centralized Control Group No. Setting.....	68
5.1 BRC1E73 .....	68
5.2 BRC1H71W.....	70
5.3 Wireless Remote Controller .....	70
5.4 Group No. Setting Example.....	71
6. Service Settings Menu, Maintenance Menu.....	72
6.1 BRC1E73 .....	72
7. Administrator Menu, Installer Menu .....	76
7.1 BRC1H71W.....	76

## **Part 4 Functions and Control ..... 77**

1. Operation Mode .....	79
2. Basic Control .....	80
2.1 Normal Operation .....	80
2.2 Compressor PI Control.....	81
2.3 Electronic Expansion Valve PI Control.....	83
2.4 Cooling Operation Fan Control.....	83
3. Special Control.....	84
3.1 Startup Control .....	84
3.2 Oil Return Control.....	86
3.3 Defrost Control .....	88
3.4 Pump Down Residual Control .....	89
3.5 Restart Standby.....	90
3.6 Stop Control .....	90
4. Protection Control .....	91
4.1 High Pressure Protection Control.....	91
4.2 Low Pressure Protection Control.....	92
4.3 Discharge Pipe Temperature Protection Control.....	93
4.4 Inverter Protection Control .....	94
5. Other Control.....	96
5.1 Demand Operation .....	96
5.2 Heating Operation Prohibition .....	96
5.3 Gas Furnace Operation Prohibition.....	96
5.4 Gas Furnace Operation Startup Prohibition .....	96
6. Outline of Control (Indoor Unit) .....	97
6.1 Operation Flowchart.....	97
6.2 Set Temperature and Control Target Temperature .....	101
6.3 Remote Controller Thermistor .....	103
6.4 Thermostat Control.....	105
6.5 Drain Pump Control.....	108
6.6 Control of Electronic Expansion Valve .....	110
6.7 Freeze-Up Prevention .....	111
6.8 List of Swing Flap Operations .....	113
6.9 Hot Start Control (In Heating Operation Only).....	114
6.10 Louver Control for Preventing Ceiling Dirt.....	115
6.11 Heater Control (Except FXTQ-TA Models).....	116

6.12 Heater Control (FXTQ-TA Models).....	117
6.13 Gas Furnace Control (CXTQ-TA Models) .....	120
6.14 3-Step Thermostat Processing (FXTQ-TA Models) .....	121
6.15 2-Step Thermostat Processing (CXTQ-TA Models) .....	122
6.16 Fan Control (Heater Residual) (FXTQ-TA Models) .....	123
6.17 Interlocked with External Equipment (FXTQ-TA and CXTQ-TA Models)...	123

## **Part 5 Field Settings and Test Operation ..... 125**

1. Field Setting from Remote Controller .....	126
1.1 BRC1E73 .....	126
1.2 BRC1H71W.....	128
1.3 Wireless Remote Controller .....	131
1.4 List of Field Settings for Indoor Unit .....	132
1.5 Details of Field Settings for Indoor Unit.....	136
1.6 Gas Furnace Set Up.....	153
1.7 List of Field Settings for Outdoor-Air Processing Unit .....	154
1.8 Setting of Operation Control Mode .....	154
2. Field Settings from Outdoor Unit.....	156
2.1 Setting Mode and Monitor Mode .....	156
2.2 Setting Mode 1 .....	157
2.3 Setting Mode 2 .....	158
2.4 Monitor Mode .....	164
2.5 Setting of Low Noise Operation and Demand Operation .....	166
2.6 Setting of Refrigerant Recovery Mode .....	168
2.7 Setting of Vacuuming Mode .....	169
2.8 Final Charge Adjustment.....	169
2.9 Check Operation .....	170
2.10 Setting of Auxiliary Heater Control .....	171
2.11 Setting of Heat Pump Lockout and Emergency Heat Mode.....	172
3. Test Operation .....	174
3.1 Check Work Prior to Turning Power Supply ON .....	174
3.2 Turn Power ON .....	174
3.3 Test Operation.....	175
3.4 Gas Furnace Test Operation.....	178
3.5 Error Codes and Corresponding Measures.....	179
3.6 When Turning ON Power First Time .....	181
3.7 When Turning ON Power the Second Time and Subsequent.....	181
3.8 When an Indoor Unit or Outdoor Unit has been Added, or Indoor or Outdoor Unit PCB has been Changed .....	181

## **Part 6 Service Diagnosis ..... 182**

1. Servicing Items to be Confirmed .....	185
1.1 Troubleshooting.....	185
1.2 Precautions for Maintenance.....	185
1.3 Refrigerant Properties (R-410A).....	187
2. Symptom-based Troubleshooting .....	188
2.1 Indoor Unit Overall .....	188

2.2	With Optional Infrared Presence/Floor Sensor.....	191
2.3	With Gas Furnace .....	192
2.4	Gas Furnace Lockout Reset.....	192
3.	Error Code via Remote Controller.....	193
3.1	Wired Remote Controller.....	193
3.2	Wireless Remote Controller .....	194
4.	Error Code Indication by Outdoor Unit PCB.....	196
5.	Troubleshooting by Error Code .....	200
5.1	Error Codes and Descriptions .....	200
5.2	Error Codes (Sub Codes).....	202
5.3	External Protection Device Abnormality .....	204
5.4	Indoor Unit Control PCB Abnormality.....	206
5.5	Drain Level Control System Abnormality.....	207
5.6	Indoor Fan Motor Lock, Overload.....	209
5.7	Indoor Fan Motor Abnormality.....	211
5.8	Blower Motor Not Running .....	215
5.9	Indoor Fan Motor Status Abnormality.....	216
5.10	Low Indoor Airflow.....	217
5.11	Swing Flap Motor Abnormality .....	218
5.12	Power Supply Voltage Abnormality .....	220
5.13	Blower Motor Stops for Over/Under Voltage .....	221
5.14	Electronic Expansion Valve Coil Abnormality, Dust Clogging .....	222
5.15	Gas Furnace Abnormality.....	223
5.16	Drain Level above Limit.....	224
5.17	Self-Cleaning Decoration Panel Abnormality .....	225
5.18	Capacity Determination Device Abnormality .....	236
5.19	Transmission Abnormality between Indoor Unit Control PCB and Fan PCB.....	237
5.20	Blower Motor Communication Error .....	239
5.21	Climate Talk Communication Error .....	240
5.22	Thermistor Abnormality .....	241
5.23	Combination Error between Indoor Unit Control PCB and Fan PCB .....	242
5.24	Blower Motor HP Mismatch.....	243
5.25	Indoor Blower Does Not Have Required Parameters to Function.....	244
5.26	Remote Sensor Abnormality .....	245
5.27	Humidity Sensor System Abnormality .....	246
5.28	Infrared Presence/Floor Sensor Error .....	247
5.29	Remote Controller Thermistor Abnormality .....	252
5.30	Outdoor Unit Main PCB Abnormality.....	253
5.31	Activation of High Pressure Switch .....	254
5.32	Activation of Low Pressure Sensor .....	256
5.33	Compressor Motor Lock.....	257
5.34	Outdoor Fan Motor Abnormality .....	259
5.35	Electronic Expansion Valve Coil Abnormality.....	261
5.36	Discharge Pipe Temperature Abnormality .....	262
5.37	Thermistor Abnormality .....	263
5.38	High Pressure Sensor Abnormality .....	264
5.39	Low Pressure Sensor Abnormality .....	265
5.40	Inverter PCB Abnormality.....	266

5.41	Radiation Fin Temperature Rise Abnormality .....	267
5.42	Compressor Instantaneous Overcurrent .....	268
5.43	Compressor Overcurrent.....	269
5.44	Compressor Startup Abnormality .....	270
5.45	Transmission Error between Microcomputers on Outdoor Unit Main PCB .....	271
5.46	Inverter Circuit Capacitor High Voltage .....	272
5.47	Radiation Fin Thermistor Abnormality .....	273
5.48	Refrigerant Shortage .....	274
5.49	Power Supply Insufficient or Instantaneous Abnormality .....	276
5.50	Check Operation Not Executed.....	278
5.51	Transmission Error between Indoor Units and Outdoor Units.....	279
5.52	Transmission Error between Remote Controller and Indoor Unit.....	281
5.53	Transmission Error between Main and Sub Remote Controllers .....	282
5.54	Transmission Error between Indoor Units and Outdoor Units in the Same System .....	283
5.55	Improper Combination of Indoor and Outdoor Units, Indoor Units and Remote Controller .....	284
5.56	Incorrect Gas Furnace Connecting Number.....	286
5.57	Incorrect Electric Heater Capacity Setting.....	287
5.58	Address Duplication of Centralized Controller.....	288
5.59	Transmission Error between Centralized Controller and Indoor Unit.....	289
5.60	System Not Set Yet .....	292
5.61	System Abnormality, Refrigerant System Address Undefined .....	293
5.62	Climate Talk Communication System Combination Error (Before Initial Setting for Communication Completes).....	294
5.63	Climate Talk Communication System Combination Error (After Initial Setting for Communication Completes).....	295
5.64	Defective PCB .....	296
5.65	Transmission Error (between Centralized Controllers) .....	297
5.66	Poor Centralized Controller Combination .....	299
5.67	Address Duplication, Poor Setting.....	301
5.68	Operation Lamp Blinking .....	303
5.69	Central Control Indicator Lamp Blinking (One blink) .....	305
5.70	Central Control Indicator Lamp Blinking (Two blinks) .....	308
6.	Check .....	309
6.1	High Pressure Check .....	309
6.2	Low Pressure Check .....	310
6.3	Superheat Operation Check.....	312
6.4	Power Transistor Check .....	314
6.5	Refrigerant Overcharge Check.....	315
6.6	Refrigerant Shortage Check.....	316
6.7	Vacuuming and Dehydration Procedure .....	317
6.8	List of Inverter-Related Error Codes.....	318
6.9	Concept of Inverter-Related Error Codes.....	319
6.10	Thermistor Check .....	320
6.11	Pressure Sensor Check .....	323
6.12	Master Unit Centralized Connector Setting Table .....	324
6.13	Master-Slave Unit Setting Table.....	325

6.14 Broken Wire Check of the Relay Wires ..... 325  
6.15 Fan Motor Connector Check (Power Supply Cable) ..... 326  
6.16 Fan Motor Connector Check (Signal Cable) ..... 327  
6.17 Electronic Expansion Valve Coil Check ..... 329  
6.18 Fan Motor Connector Check for FXTQ-TA..... 331

**Part 7 Appendix..... 335**

1. Wiring Diagrams..... 336  
1.1 Outdoor Unit..... 336  
1.2 Indoor Unit..... 342  
1.3 Air Treatment Equipment ..... 361

# Introduction

1. Safety Cautions.....	2
1.1 Warnings and Cautions Regarding Safety of Workers.....	2
1.2 Warnings and Cautions Regarding Safety of Users.....	4
2. Icons Used .....	7
3. Revision History .....	8



# 1. Safety Cautions

Be sure to read the following safety cautions before conducting repair work. After the repair work is complete, be sure to conduct a test operation to ensure that the equipment operates normally, and explain the cautions for operating the product to the customer.

	This manual is for the person in charge of maintenance and inspection.
---	--







## Caution Items







The caution items are classified into **Warning** and **Caution**. The **Warning** items are especially important since death or serious injury can result if they are not followed closely. The **Caution** items can also lead to serious accidents under some conditions if they are not followed. Therefore, be sure to observe all the safety caution items described below.







## Pictograms



- △ This symbol indicates an item for which caution must be exercised. The pictogram shows the item to which attention must be paid.
- This symbol indicates a prohibited action. The prohibited item or action is shown in the illustration or near the symbol.
- This symbol indicates an action that must be taken, or an instruction. The instruction is shown in the illustration or near the symbol.

## 1.1 Warnings and Cautions Regarding Safety of Workers









 <b>Warning</b>	
<p><b>Do not store equipment in a room with fire sources (e.g., naked flames, gas appliances, electric heaters).</b></p>	
<p><b>Be sure to disconnect the power cable from the socket before disassembling equipment for repair.</b> Working on equipment that is connected to the power supply may cause an electrical shock. If it is necessary to supply power to the equipment to conduct the repair or inspect the circuits, do not touch any electrically charged sections of the equipment.</p>	
<p><b>If refrigerant gas is discharged during repair work, do not touch the discharged refrigerant gas.</b> Refrigerant gas may cause frostbite.</p>	
<p><b>When disconnecting the suction or discharge pipe of the compressor at the welded section, evacuate the refrigerant gas completely at a well-ventilated place first.</b> If there is gas remaining inside the compressor, the refrigerant gas or refrigerating machine oil discharges when the pipe is disconnected, and it may cause injury.</p>	
<p><b>If refrigerant gas leaks during repair work, ventilate the area.</b> Refrigerant gas may generate toxic gases when it contacts flames.</p>	







 <b>Warning</b>	
<p><b>Be sure to discharge the capacitor completely before conducting repair work.</b> The step-up capacitor supplies high-voltage electricity to the electrical components of the outdoor unit. A charged capacitor may cause an electrical shock.</p>	
<p><b>Do not turn the air conditioner on or off by plugging in or unplugging the power cable.</b> Plugging in or unplugging the power cable to operate the equipment may cause an electrical shock or fire.</p>	
<p><b>Be sure to wear a safety helmet, gloves, and a safety belt when working in a high place (more than 2 m (6.5 ft)).</b> Insufficient safety measures may cause a fall.</p>	
<p><b>In case of R-410A refrigerant models, be sure to use pipes, flare nuts and tools intended for the exclusive use with the R-410A refrigerant.</b> The use of materials for other refrigerant models may cause a serious accident, such as damage to the refrigerant cycle or equipment failure.</p>	
<p><b>Do not mix air or gas other than the specified refrigerant (R-410A) in the refrigerant system.</b> If air enters the refrigerant system, an excessively high pressure results, causing equipment damage and injury.</p>	







 <b>Caution</b>	
<p><b>Do not repair electrical components with wet hands.</b> Working on the equipment with wet hands may cause an electrical shock.</p>	
<p><b>Do not clean the air conditioner with water.</b> Washing the unit with water may cause an electrical shock.</p>	
<p><b>Be sure to provide an earth / grounding when repairing the equipment in a humid or wet place, to avoid electrical shocks.</b></p>	
<p><b>Be sure to turn off the power switch and unplug the power cable when cleaning the equipment.</b> The internal fan rotates at a high speed, and may cause injury.</p>	
<p><b>Be sure to conduct repair work with appropriate tools.</b> The use of inappropriate tools may cause injury.</p>	





 <b>Caution</b>	
<p><b>Be sure to check that the refrigerating cycle section has cooled down enough before conducting repair work.</b> Working on the unit when the refrigerating cycle section is hot may cause burns.</p>	
<p><b>Conduct welding work in a well-ventilated place.</b> Using the welder in an enclosed room may cause oxygen deficiency.</p>	

## 1.2 Warnings and Cautions Regarding Safety of Users

 <b>Warning</b>	
<p><b>Do not store the equipment in a room with fire sources (e.g., naked flames, gas appliances, electric heaters).</b></p>	
<p><b>Be sure to use parts listed in the service parts list of the applicable model and appropriate tools to conduct repair work. Never attempt to modify the equipment.</b> The use of inappropriate parts or tools may cause an electrical shock, excessive heat generation or fire.</p>	
<p><b>If the power cable and lead wires are scratched or have deteriorated, be sure to replace them.</b> Damaged cable and wires may cause an electrical shock, excessive heat generation or fire.</p>	
<p><b>Do not use a joined power cable or extension cable, or share the same power outlet with other electrical appliances, since it may cause an electrical shock, excessive heat generation or fire.</b></p>	
<p><b>Be sure to use an exclusive power circuit for the equipment, and follow the local technical standards related to the electrical equipment, the internal wiring regulations, and the instruction manual for installation when conducting electrical work.</b> Insufficient power circuit capacity and improper electrical work may cause an electrical shock or fire.</p>	
<p><b>Be sure to use the specified cable for wiring between the indoor and outdoor units.</b> Make the connections securely and route the cable properly so that there is no force pulling the cable at the connection terminals. Improper connections may cause excessive heat generation or fire.</p>	
<p><b>When wiring between the indoor and outdoor units, make sure that the terminal cover does not lift off or dismount because of the cable.</b> If the cover is not mounted properly, the terminal connection section may cause an electrical shock, excessive heat generation or fire.</p>	
<p><b>Do not damage or modify the power cable.</b> Damaged or modified power cables may cause an electrical shock or fire. Placing heavy items on the power cable, or heating or pulling the power cable may damage it.</p>	





 <b>Warning</b>	
<p><b>Do not mix air or gas other than the specified refrigerant (R-410A) in the refrigerant system.</b> If air enters the refrigerant system, an excessively high pressure results, causing equipment damage and injury.</p>	
<p><b>If the refrigerant gas leaks, be sure to locate the leaking point and repair it before charging the refrigerant. After charging the refrigerant, make sure that there is no leak.</b> If the leaking point cannot be located and the repair work must be stopped, be sure to pump-down, and close the service valve, to prevent refrigerant gas from leaking into the room. Refrigerant gas itself is harmless, but it may generate toxic gases when it contacts flames, such as those from fan type and other heaters, stoves and ranges.</p>	
<p><b>When relocating the equipment, make sure that the new installation site has sufficient strength to withstand the weight of the equipment.</b> If the installation site does not have sufficient strength or the installation work is not conducted securely, the equipment may fall and cause injury.</p>	
<p><b>Check to make sure that the power cable plug is not dirty or loose, then insert the plug into a power outlet securely.</b> If the plug is dusty or has a loose connection, it may cause an electrical shock or fire.</p>	
<p><b>When replacing the coin battery in the remote controller, be sure to dispose of the old battery to prevent children from swallowing it.</b> If a child swallows the coin battery, see a doctor immediately.</p>	

 <b>Caution</b>	
<p><b>Installation of a leakage breaker is necessary in some cases depending on the conditions of the installation site, to prevent electrical shocks.</b></p>	
<p><b>Do not install the equipment in a place where there is a possibility of combustible gas leaks.</b> If combustible gas leaks and remains around the unit, it may cause a fire.</p>	
<p><b>Check to see if parts and wires are mounted and connected properly, and if connections at the soldered or crimped terminals are secure.</b> Improper installation and connections may cause excessive heat generation, fire or an electrical shock.</p>	
<p><b>If the installation platform or frame has corroded, replace it.</b> A corroded installation platform or frame may cause the unit to fall, resulting in injury.</p>	
<p><b>Check the earth / grounding, and repair it if the equipment is not properly earthed / grounded.</b> Improper earth / grounding may cause an electrical shock.</p>	

 <b>Caution</b>	
<b>Be sure to measure insulation resistance after the repair, and make sure that the resistance is 1 M<math>\Omega</math> or greater.</b> Faulty insulation may cause an electrical shock.	
<b>Be sure to check the drainage of the indoor unit after the repair.</b> Faulty drainage may cause water to enter the room and wet the furniture and floor.	
<b>Do not tilt the unit when removing it.</b> The water inside the unit may spill and wet the furniture and floor.	

## 2. Icons Used

The following icons are used to attract the attention of the reader to specific information.

Icon	Type of Information	Description
 Warning	Warning	<b>Warning</b> is used when there is danger of personal injury.
 Caution	Caution	<b>Caution</b> is used when there is danger that the reader, through incorrect manipulation, may damage equipment, lose data, get an unexpected result or have to restart (part of) a procedure.
 Note	Note	<b>Note</b> provides information that is not indispensable, but may nevertheless be valuable to the reader, such as tips and tricks.
 Reference	Reference	<b>Reference</b> guides the reader to other places in this binder or in this manual, where he/she will find additional information on a specific topic.

### 3. Revision History

Month / Year	Version	Revised contents
08 / 2017	SiUS331708E	First edition
09 / 2018	SiUS331708EA	Model addition: FXZQ05-18TAVJU, FXSQ05-54TAVJU
03 / 2020	SiUS331708EB	Model addition: RXSQ24-60TAVJUA
11 / 2022	SiUS331708EC	Model addition: RXSQ24-60TBVJUA, FXZQ05-18TBVJU, FXUQ18-36PAVJU, FXSQ05-54TBVJU, FXMQ15-54TBVJU, BRC1H71W

---

# Part 1

## General Information

1. Model Names and Power Supply .....	10
1.1 Outdoor Unit .....	10
1.2 Indoor Unit .....	10
1.3 Air Treatment Equipment .....	11
2. External Appearance .....	12
2.1 Outdoor Unit .....	12
2.2 Indoor Unit .....	12
2.3 Air Treatment Equipment .....	13
3. Capacity Range .....	14
3.1 Connection Ratio .....	14
3.2 Outdoor Unit Combinations .....	14
4. Specifications .....	15



# 1. Model Names and Power Supply

## 1.1 Outdoor Unit

Capacity range (ton)		2	3	4	5	Power supply, Standard
Capacity index		24	36	48	57	
Heat Pump	RXSQ	24TA	36TA	48TA	60TA	VJU
		24TA	36TA	48TA	60TA	VJUA
		24TB	36TB	48TB	60TB	

VJ: 1 phase, 208/230 V, 60 Hz

U(VJU): Standard symbol

A: Minor revision

## 1.2 Indoor Unit

Capacity range (ton)		0.5	0.6	0.8	1	1.25	1.5	2	2.5	3	3.5	4	4.5	5	Power supply, Standard	
Capacity index		5.8	7.5	9.5	12	15	18	20	24	30	36	42	48	54		60
Ceiling mounted cassette (Round flow with sensing) type	FXFQ	—	07T	09T	12T	15T	18T	—	24T	30T	36T	—	48T	—	—	VJU
Ceiling mounted cassette (Round flow) type		—	—	09P	12P	—	18P	—	24P	30P	36P	—	48P	—	—	
VISTA™ 2'x2' cassette type	FXZQ	05TA	07TA	09TA	12TA	15TA	18TA	—	—	—	—	—	—	—	—	VJU9
		05TB	07TB	09TB	12TB	15TB	18TB	—	—	—	—	—	—	—	—	
4-way ceiling mounted cassette (2'x2') type	FXUQ	—	07M	09M	12M	15M	18M	—	—	—	—	—	—	—	—	VJU9
4-way blow ceiling suspended type		—	—	—	—	—	—	—	18P	24P	30P	36P	—	—	—	
One way blow cassette type	FXEQ	—	07P	09P	12P	15P	18P	—	24P	—	—	—	—	—	—	VJU
Slim ceiling mounted duct type	FXDQ	—	07M	09M	12M	—	18M	—	24M	—	—	—	—	—	—	
MSP concealed ducted type	FXSQ	05TA	07TA	09TA	12TA	15TA	18TA	—	24TA	30TA	36TA	—	48TA	54TA	—	
		05TB	07TB	09TB	12TB	15TB	18TB	—	24TB	30TB	36TB	—	48TB	54TB	—	
Ceiling mounted duct type (Middle and high static pressure)	FXMQ	—	07PB	09PB	12PB	15PB	18PB	—	24PB	30PB	36PB	—	48PB	54PB	—	
Ceiling mounted duct type (High static pressure)		—	—	—	—	15TB	18TB	—	24TB	30TB	36TB	—	48TB	54TB	—	
Ceiling suspended type	FXHQ	—	—	—	12M	—	—	—	24M	—	36M	—	—	—	—	
Wall mounted type	FXAQ	—	07P	09P	12P	—	18P	—	24P	—	—	—	—	—	—	
Floor standing type	FXLQ	—	07M	09M	12M	—	18M	—	24M	—	—	—	—	—	—	
Concealed floor standing type	FXNQ	—	07M	09M	12M	—	18M	—	24M	—	—	—	—	—	—	
Air handling unit	FXTQ	—	—	09TA	12TA	—	18TA	—	24TA	30TA	36TA	42TA	48TA	54TA	60TA	VJUA
		—	—	09TA	12TA	—	18TA	—	24TA	30TA	36TA	42TA	48TA	54TA	60TA	VJUD
Cased coil unit	CXTQ	—	—	—	—	—	—	—	24TA	—	36TA	—	48TA	—	60TA	SBLU

VJ: 1 phase, 208/230 V, 60 Hz

SBL: 1 phase, 115 V, 60 Hz

U(VJU): Standard symbol

## 1.3 Air Treatment Equipment

### Outdoor-Air Processing Unit

Series	Model name		Power supply, Standard
FXMQ	48MF	72MF	VJU

### Energy Recovery Ventilator (VAM series)





Series	Model name				Power supply, Standard
VAM	300G	470G	600G	1200G	VJU

VJ: 1 phase, 208/230 V, 60 Hz







U(VJU): Standard symbol









## 2. External Appearance

### 2.1 Outdoor Unit

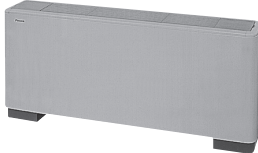
2, 3, 4 ton		5 ton	
			
RXSQ24TAVJU RXSQ24TAVJUA RXSQ36TAVJU RXSQ36TAVJUA RXSQ48TAVJU RXSQ48TAVJUA	RXSQ24TBVJUA RXSQ36TBVJUA RXSQ48TBVJUA	RXSQ60TAVJU RXSQ60TAVJUA	RXSQ60TBVJUA

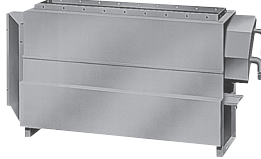
### 2.2 Indoor Unit

Ceiling mounted cassette (Round flow with sensing) type FXFQ-T  Shown with BYCQ125B-W1	4-way ceiling mounted cassette (2'x2') type FXZQ-M  Shown with BYFQ60B8W1U
Ceiling mounted cassette (Round flow) type FXFQ-P  Shown with BYCP125K-W1	4-way blow ceiling suspended type FXUQ-P FXUQ-PA 
VISTA™ 2'x2' cassette type FXZQ-TA FXZQ-TB   Shown with BYFQ60C3W1W/ BYFQ60C3W2W	One way blow cassette type FXEQ-P 

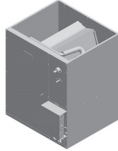
<p>Slim ceiling mounted duct type FXDQ-M</p> 	<p>Wall mounted type FXAQ-P</p> 
<p>MSP concealed ducted type FXSQ-TA FXSQ-TB</p> 	<p>Floor standing type FXLQ-M</p> 
<p>Ceiling mounted duct type (Middle and high static pressure) FXMQ-PB</p> 	<p>Concealed floor standing type FXNQ-M</p> 
<p>Ceiling mounted duct type (High static pressure) FXMQ-TB</p> 	<p>Air handling unit FXTQ-TA</p> 
<p>Ceiling suspended type FXHQ-M</p> 	<p>Cased coil unit CXTQ-TA</p> 

## 2.3 Air Treatment Equipment

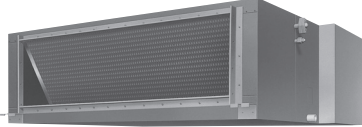
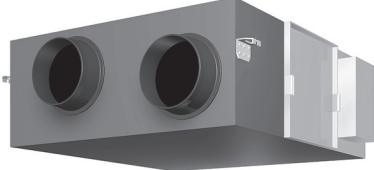
<p>Outdoor-air processing unit FXMQ-MF</p> 	<p>Energy recovery ventilator (VAM series) VAM-G</p> 
--	---

## 3. Capacity Range

### 3.1 Connection Ratio

$$\text{Connection ratio} = \frac{\text{Total capacity index of the indoor units}}{\text{Capacity index of the outdoor units}}$$

Type	Min. connection ratio	Max. connection ratio
		Types of connected indoor units
		<b>VRV</b> indoor units
Single outdoor unit	50%	130%

### 3.2 Outdoor Unit Combinations

Model	RXSQ24TAVJU	RXSQ36TAVJU	RXSQ48TAVJU	RXSQ60TAVJU
	RXSQ24TAVJUA	RXSQ36TAVJUA	RXSQ48TAVJUA	RXSQ60TAVJUA
	RXSQ24TBVJUA	RXSQ36TBVJUA	RXSQ48TBVJUA	RXSQ60TBVJUA
Capacity range (ton)	2	3	4	5
Capacity index	24	36	48	57
Maximum number of connectable indoor units	4	6	8	9
Total capacity index of indoor units to be connected	12.0 ~ 31.2	18.0 ~ 46.8	24.0 ~ 62.4	28.5 ~ 74.1

## 4. Specifications

Model name			RXSQ24TAVJU	RXSQ36TAVJU
Power supply			1 phase, 208/230 V, 60 Hz	1 phase, 208/230 V, 60 Hz
★1 Cooling capacity	Nominal	Btu/h (kW)	24,000 (7.0)	36,000 (10.6)
	Rated		23,000 (6.7)	34,200 (10.0)
★2 Heating capacity	Nominal	Btu/h (kW)	27,000 (7.9)	40,000 (11.7)
	Rated		Non-Ducted: 25,800 (7.6) Ducted: 25,000 (7.3)	37,000 (10.8)
Casing color			Ivory white	Ivory white
Dimensions: (H × W × D)		in (mm)	39 × 37 × 12-5/8 (990 × 940 × 320)	39 × 37 × 12-5/8 (990 × 940 × 320)
Heat exchanger			Cross fin coil	Cross fin coil
Compressor	Type		Hermetically sealed swing type	Hermetically sealed swing type
	Motor output	kW	1.9	1.9
	Starting method		Soft start	Soft start
Fan	Type		Propeller fan	Propeller fan
	Motor output	kW	0.200	0.200
	Airflow rate	cfm (m <sup>3</sup> /min)	2,682 (76)	2,682 (76)
	Drive		Direct drive	Direct drive
Sound pressure level (Reference data)	Cooling	dBA	58	58
	Heating	dBA	61	61
Sound power level (Reference data)	Cooling	dB	75	75
	Heating	dB	79	79
Connecting pipes	Liquid pipe	in (mm)	ϕ 3/8 (9.5) C1220T (Flare connection)	ϕ 3/8 (9.5) C1220T (Flare connection)
	Gas pipe	in (mm)	ϕ 5/8 (15.9) C1220T (Flare connection)	ϕ 5/8 (15.9) C1220T (Flare connection)
Mass		lbs (kg)	172 (78)	172 (78)
Safety devices			High pressure switch, Fan driver overload protector, Inverter overload protector, Fusible plug, Fuse	High pressure switch, Fan driver overload protector, Inverter overload protector, Fusible plug, Fuse
Defrost method			Reverse cycle defrosting	Reverse cycle defrosting
Capacity control		%	14-100	14-100
Refrigerant	Refrigerant name		R-410A	R-410A
	Charge	lbs (kg)	6.4 (2.9)	6.4 (2.9)
	Control		Electronic expansion valve	Electronic expansion valve
Standard accessories			Installation manual, Operation manual, Drain socket, Clamps	Installation manual, Operation manual, Drain socket, Clamps
Drawing No.			4D109792B	4D109792B

### Notes:

- ★1. Indoor temp.: 80°FDB (26.7°CDB), 67°FWB (19.4°CWB) / Outdoor temp.: 95°FDB (35.0°CDB) / Equivalent piping length: 25 ft (7.6 m), level difference: 0 ft (0 m).  
 ★2. Indoor temp.: 70°FDB (21.1°CDB) / Outdoor temp.: 47°FDB (8.3°CDB), 43°FWB (6.1°CWB) / Equivalent piping length: 25 ft (7.6 m), level difference: 0 ft (0 m).

Model name			RXSQ48TAVJU	RXSQ60TAVJU
Power supply			1 phase, 208/230 V, 60 Hz	1 phase, 208/230 V, 60 Hz
★1 Cooling capacity	Nominal	Btu/h (kW)	48,000 (14.1)	57,500 (16.9)
	Rated		45,500 (13.3)	57,500 (16.9)
★2 Heating capacity	Nominal	Btu/h (kW)	52,000 (15.2)	57,000 (16.7)
	Rated		49,500 (14.5)	57,000 (16.7)
Casing color			Ivory white	Ivory white
Dimensions: (H × W × D)		in (mm)	39 × 37 × 12-5/8 (990 × 940 × 320)	52-15/16 × 35-7/16 × 12-5/8 (1,345 × 900 × 320)
Heat exchanger			Cross fin coil	Cross fin coil
Compressor	Type		Hermetically sealed swing type	Hermetically sealed swing type
	Motor output	kW	3.0	3.5
	Starting method		Soft start	Soft start
Fan	Type		Propeller fan	Propeller fan
	Motor output	kW	0.200	0.070 × 2
	Airflow rate	cfm (m <sup>3</sup> /min)	2,682 (76)	3,741 (106)
	Drive		Direct drive	Direct drive
Sound pressure level (Reference data)	Cooling	dBA	58	57
	Heating	dBA	61	59
Sound power level (Reference data)	Cooling	dB	76	74
	Heating	dB	78	77
Connecting pipes	Liquid pipe	in (mm)	ϕ 3/8 (9.5) C1220T (Flare connection)	ϕ 3/8 (9.5) C1220T (Flare connection)
	Gas pipe	in (mm)	ϕ 5/8 (15.9) C1220T (Flare connection)	ϕ 3/4 (19.1) C1220T (Flare connection)
Mass		lbs (kg)	176 (80)	225 (102)
Safety devices			High pressure switch, Fan driver overload protector, Inverter overload protector, Fusible plug, Fuse	High pressure switch, Fan driver overload protector, Inverter overload protector, Fusible plug, Fuse
Defrost method			Reverse cycle defrosting	Reverse cycle defrosting
Capacity control		%	14-100	14-100
Refrigerant	Refrigerant name		R-410A	R-410A
	Charge	lbs (kg)	7.5 (3.4)	7.9 (3.6)
	Control		Electronic expansion valve	Electronic expansion valve
Standard accessories			Installation manual, Operation manual, Drain socket, Clamps	Installation manual, Operation manual, Drain socket, Clamps, Auxiliary piping
Drawing No.			4D109793A	4D109794A

**Notes:**

★1. Indoor temp.: 80°FDB (26.7°CDB), 67°FWB (19.4°CWB) / Outdoor temp.: 95°FDB (35.0°CDB) / Equivalent piping length: 25 ft (7.6 m), level difference: 0 ft (0 m).

★2. Indoor temp.: 70°FDB (21.1°CDB) / Outdoor temp.: 47°FDB (8.3°CDB), 43°FWB (6.1°CWB) / Equivalent piping length: 25 ft (7.6 m), level difference: 0 ft (0 m).

Model name			RXSQ24TAVJUA	RXSQ36TAVJUA
Power supply			1 phase, 208/230 V, 60 Hz	1 phase, 208/230 V, 60 Hz
★1 Cooling capacity	Nominal	Btu/h (kW)	24,000 (7.0)	36,000 (10.6)
	Rated		23,000 (6.7)	34,200 (10.0)
★2 Heating capacity	Nominal	Btu/h (kW)	27,000 (7.9)	40,000 (11.7)
	Rated		Non-Ducted: 25,800 (7.6) Ducted: 25,000 (7.3)	37,000 (10.8)
Casing color			Ivory white	Ivory white
Dimensions: (H × W × D)		in (mm)	39 × 37 × 12-5/8 (990 × 940 × 320)	39 × 37 × 12-5/8 (990 × 940 × 320)
Heat exchanger			Cross fin coil	Cross fin coil
Compressor	Type		Hermetically sealed swing type	Hermetically sealed swing type
	Motor output	kW	1.9	1.9
	Starting method		Soft start	Soft start
Fan	Type		Propeller fan	Propeller fan
	Motor output	kW	0.200	0.200
	Airflow rate	cfm (m <sup>3</sup> /min)	2,682 (76)	2,682 (76)
	Drive		Direct drive	Direct drive
Sound pressure level (Reference data)	Cooling	dBA	58	58
	Heating	dBA	61	61
Sound power level (Reference data)	Cooling	dB	75	75
	Heating	dB	79	79
Connecting pipes	Liquid pipe	in (mm)	ϕ 3/8 (9.5) C1220T (Flare connection)	ϕ 3/8 (9.5) C1220T (Flare connection)
	Gas pipe	in (mm)	ϕ 5/8 (15.9) C1220T (Flare connection)	ϕ 5/8 (15.9) C1220T (Flare connection)
Mass		lbs (kg)	172 (78)	172 (78)
Safety devices			High pressure switch, Fan driver overload protector, Inverter overload protector, Fusible plug, Fuse	High pressure switch, Fan driver overload protector, Inverter overload protector, Fusible plug, Fuse
Defrost method			Reverse cycle defrosting	Reverse cycle defrosting
Capacity control		%	14-100	14-100
Refrigerant	Refrigerant name		R-410A	R-410A
	Charge	lbs (kg)	6.4 (2.9)	6.4 (2.9)
	Control		Electronic expansion valve	Electronic expansion valve
Standard accessories			Installation manual, Operation manual, Drain socket, Clamps	Installation manual, Operation manual, Drain socket, Clamps
Drawing No.			4D126372	4D126372

**Notes:**

- ★1. Indoor temp.: 80°FDB (26.7°CDB), 67°FWB (19.4°CWB) / Outdoor temp.: 95°FDB (35.0°CDB) / Equivalent piping length: 25 ft (7.6 m), level difference: 0 ft (0 m).
- ★2. Indoor temp.: 70°FDB (21.1°CDB) / Outdoor temp.: 47°FDB (8.3°CDB), 43°FWB (6.1°CWB) / Equivalent piping length: 25 ft (7.6 m), level difference: 0 ft (0 m).



Model name			RXSQ48TAVJUA	RXSQ60TAVJUA
Power supply			1 phase, 208/230 V, 60 Hz	1 phase, 208/230 V, 60 Hz
★1 Cooling capacity	Nominal	Btu/h (kW)	48,000 (14.1)	57,500 (16.9)
	Rated		45,500 (13.3)	57,500 (16.9)
★2 Heating capacity	Nominal	Btu/h (kW)	52,000 (15.2)	57,000 (16.7)
	Rated		49,500 (14.5)	57,000 (16.7)
Casing color			Ivory white	Ivory white
Dimensions: (H × W × D)		in (mm)	39 × 37 × 12-5/8 (990 × 940 × 320)	52-15/16 × 35-7/16 × 12-5/8 (1,345 × 900 × 320)
Heat exchanger			Cross fin coil	Cross fin coil
Compressor	Type		Hermetically sealed swing type	Hermetically sealed swing type
	Motor output	kW	3.0	3.5
	Starting method		Soft start	Soft start
Fan	Type		Propeller fan	Propeller fan
	Motor output	kW	0.200	0.070 × 2
	Airflow rate	cfm (m <sup>3</sup> /min)	2,682 (76)	3,741 (106)
	Drive		Direct drive	Direct drive
Sound pressure level (Reference data)	Cooling	dBA	58	57
	Heating	dBA	61	59
Sound power level (Reference data)	Cooling	dB	76	74
	Heating	dB	78	77
Connecting pipes	Liquid pipe	in (mm)	ϕ 3/8 (9.5) C1220T (Flare connection)	ϕ 3/8 (9.5) C1220T (Flare connection)
	Gas pipe	in (mm)	ϕ 5/8 (15.9) C1220T (Flare connection)	ϕ 3/4 (19.1) C1220T (Flare connection)
Mass		lbs (kg)	176 (80)	225 (102)
Safety devices			High pressure switch, Fan driver overload protector, Inverter overload protector, Fusible plug, Fuse	High pressure switch, Fan driver overload protector, Inverter overload protector, Fusible plug, Fuse
Defrost method			Reverse cycle defrosting	Reverse cycle defrosting
Capacity control		%	14-100	14-100
Refrigerant	Refrigerant name		R-410A	R-410A
	Charge	lbs (kg)	7.5 (3.4)	7.9 (3.6)
	Control		Electronic expansion valve	Electronic expansion valve
Standard accessories			Installation manual, Operation manual, Drain socket, Clamps	Installation manual, Operation manual, Drain socket, Clamps, Auxiliary piping
Drawing No.			4D126374	4D126376

**Notes:**

★1. Indoor temp.: 80°FDB (26.7°CDB), 67°FWB (19.4°CWB) / Outdoor temp.: 95°FDB (35.0°CDB) / Equivalent piping length: 25 ft (7.6 m), level difference: 0 ft (0 m).

★2. Indoor temp.: 70°FDB (21.1°CDB) / Outdoor temp.: 47°FDB (8.3°CDB), 43°FWB (6.1°CWB) / Equivalent piping length: 25 ft (7.6 m), level difference: 0 ft (0 m).

Model name			RXSQ24TBVJUA	RXSQ36TBVJUA
Power supply			1 phase, 208/230 V, 60 Hz	1 phase, 208/230 V, 60 Hz
★1 Cooling capacity	Nominal	Btu/h (kW)	24,000 (7.0)	36,000 (10.6)
	Rated (Non-ducted)		23,000 (6.7)	34,200 (10.0)
	Rated (Ducted)		23,000 (6.7)	34,200 (10.0)
★2 Heating capacity	Nominal	Btu/h (kW)	27,000 (7.9)	40,000 (11.7)
	Rated (Non-ducted)		25,800 (7.6)	37,000 (10.8)
	Rated (Ducted)		25,000 (7.3)	37,000 (10.8)
Casing color			Ivory white	Ivory white
Dimensions: (H × W × D)			in (mm) 39 × 37 × 12-5/8 (990 × 940 × 320)	39 × 37 × 12-5/8 (990 × 940 × 320)
Heat exchanger			Cross fin coil	Cross fin coil
Compressor	Type		Hermetically sealed swing type	Hermetically sealed swing type
	Motor output	kW	1.9	1.9
	Starting method		Soft start	Soft start
Fan	Type		Propeller fan	Propeller fan
	Motor output	kW	0.200	0.200
	Airflow rate	cfm (m <sup>3</sup> /min)	2,682 (76)	2,682 (76)
	Drive		Direct drive	Direct drive
Sound pressure level (Reference data)	Cooling	dBA	58	58
	Heating	dBA	61	61
Sound power level (Reference data)	Cooling	dB	75	75
	Heating	dB	79	79
Connecting pipes	Liquid pipe	in (mm)	ϕ 3/8 (9.5) C1220T (Flare connection)	ϕ 3/8 (9.5) C1220T (Flare connection)
	Gas pipe	in (mm)	ϕ 5/8 (15.9) C1220T (Flare connection)	ϕ 5/8 (15.9) C1220T (Flare connection)
Mass			lbs (kg) 172 (78)	172 (78)
Safety devices			High pressure switch, Fan driver overload protector, Inverter overload protector, Fusible plug, Fuse	High pressure switch, Fan driver overload protector, Inverter overload protector, Fusible plug, Fuse
Defrost method			Reverse cycle defrosting	Reverse cycle defrosting
Capacity control			% 14-100	14-100
Refrigerant	Refrigerant name		R-410A	R-410A
	Charge	lbs (kg)	6.4 (2.9)	6.4 (2.9)
	Control		Electronic expansion valve	Electronic expansion valve
Standard accessories			Installation manual, Operation manual, Drain socket, Clamps	Installation manual, Operation manual, Drain socket, Clamps
Drawing No.			4D142998A	4D142998A

**Notes:**

- ★1. Indoor temp.: 80°FDB (26.7°CDB), 67°FWB (19.4°CWB) / Outdoor temp.: 95°FDB (35.0°CDB) / Equivalent piping length: 25 ft (7.6 m), level difference: 0 ft (0 m).
- ★2. Indoor temp.: 70°FDB (21.1°CDB) / Outdoor temp.: 47°FDB (8.3°CDB), 43°FWB (6.1°CWB) / Equivalent piping length: 25 ft (7.6 m), level difference: 0 ft (0 m).

Model name			RXSQ48TBVJUA	RXSQ60TBVJUA
Power supply			1 phase, 208/230 V, 60 Hz	1 phase, 208/230 V, 60 Hz
★1 Cooling capacity	Nominal	Btu/h (kW)	48,000 (14.1)	57,500 (16.9)
	Rated (Non-ducted)		45,500 (13.3)	57,500 (16.9)
	Rated (Ducted)		45,500 (13.3)	57,500 (16.9)
★2 Heating capacity	Nominal	Btu/h (kW)	52,000 (15.2)	57,000 (16.7)
	Rated (Non-ducted)		49,500 (14.5)	57,000 (16.7)
	Rated (Ducted)		46,000 (13.5)	57,000 (16.7)
Casing color			Ivory white	Ivory white
Dimensions: (H × W × D)		in (mm)	39 × 37 × 12-5/8 (990 × 940 × 320)	52-15/16 × 35-7/16 × 12-5/8 (1,345 × 900 × 320)
Heat exchanger			Cross fin coil	Cross fin coil
Compressor	Type		Hermetically sealed swing type	
	Motor output	kW	3.0	3.5
	Starting method		Soft start	
Fan	Type		Propeller fan	
	Motor output	kW	0.200	0.070 × 2
	Airflow rate	cfm (m <sup>3</sup> /min)	2,682 (76)	3,741 (106)
	Drive		Direct drive	
Sound pressure level (Reference data)	Cooling	dBA	58	57
	Heating	dBA	61	59
Sound power level (Reference data)	Cooling	dB	76	74
	Heating	dB	78	77
Connecting pipes	Liquid pipe	in (mm)	ϕ 3/8 (9.5) C1220T (Flare connection)	ϕ 3/8 (9.5) C1220T (Flare connection)
	Gas pipe	in (mm)	ϕ 5/8 (15.9) C1220T (Flare connection)	ϕ 3/4 (19.1) C1220T (Flare connection)
Mass		lbs (kg)	176 (80)	225 (102)
Safety devices			High pressure switch, Fan driver overload protector, Inverter overload protector, Fusible plug, Fuse	High pressure switch, Fan driver overload protector, Inverter overload protector, Fusible plug, Fuse
Defrost method			Reverse cycle defrosting	Reverse cycle defrosting
Capacity control		%	14-100	14-100
Refrigerant	Refrigerant name		R-410A	
	Charge	lbs (kg)	7.5 (3.4)	7.9 (3.6)
	Control		Electronic expansion valve	
Standard accessories			Installation manual, Operation manual, Drain socket, Clamps	Installation manual, Operation manual, Drain socket, Clamps, Auxiliary piping
Drawing No.			4D142999A	4D143000A

**Notes:**

- ★1. Indoor temp.: 80°FDB (26.7°CDB), 67°FWB (19.4°CWB) / Outdoor temp.: 95°FDB (35.0°CDB) / Equivalent piping length: 25 ft (7.6 m), level difference: 0 ft (0 m).  
★2. Indoor temp.: 70°FDB (21.1°CDB) / Outdoor temp.: 47°FDB (8.3°CDB), 43°FWB (6.1°CWB) / Equivalent piping length: 25 ft (7.6 m), level difference: 0 ft (0 m).

---

# Part 2

# Refrigerant Circuit

1. Refrigerant Circuit (Piping Diagrams) .....	22
1.1 Outdoor Unit .....	22
1.2 Indoor Unit .....	31
1.3 Outdoor-Air Processing Unit .....	34
2. Functional Parts Layout .....	35
2.1 RXSQ24/36TAVJU .....	35
2.2 RXSQ24/36TAVJUA, RXSQ24/36TBVJUA .....	37
2.3 RXSQ48TAVJU .....	39
2.4 RXSQ48TAVJUA, RXSQ48TBVJUA .....	41
2.5 RXSQ60TAVJU .....	43
2.6 RXSQ60TAVJUA, RXSQ60TBVJUA .....	45

# 1. Refrigerant Circuit (Piping Diagrams)

## 1.1 Outdoor Unit

### 1.1.1 24/36 Class

No. in piping diagram	Electric symbol	Name	Function
(1)	M1C	Compressor	Compressor is operated on frequencies between 16 rps and 100.5 rps by using the inverter.
(2)	M1F	Fan motor	Because the system is of an air heat exchange type, the fan is operated at 8-step rotation speed by using the inverter.
(3)	Y1E	Electronic expansion valve (Main)	While in heating operation, PI control is applied to keep the outlet superheating degree of air heat exchanger constant.
(4)	Y1S	Four way valve	Used to switch the operation mode between cooling and heating.
(5)	Y2S	Solenoid valve (Hot gas)	Used to prevent the low pressure from transient falling.
(6)	Y3S	Solenoid valve (Unload circuit)	Used for unloading operation of compressor.
(7)	S1NPH	High pressure sensor	Used to detect high pressure.
(8)	S1NPL	Low pressure sensor	Used to detect low pressure.
(9)	S1PH	High pressure switch	In order to prevent the increase of high pressure when an error occurs, this switch is activated at high pressure of 4.0 MPa (580 psi) or more to stop the compressor operation.
(10)	—	Fusible plug	In order to prevent the increase of pressure when abnormal heating is caused by fire or others, the fusible part of the plug is molten at a temperature of 70 to 75°C (158 to 167°F) to release the pressure into the atmosphere.
(11)	—	Pressure regulating valve (Receiver to discharge pipe)	This valve opens at a pressure of 4.0 MPa (580 psi) for prevention of pressure increase, thus resulting in no damage of functional parts due to the increase of pressure in transportation or storage.
(12)	R1T	Thermistor (Outdoor air)	Used to detect outdoor air temperature, correct discharge pipe temperature, and for other purposes.
(13)	R2T	Thermistor (Discharge pipe)	Used to detect discharge pipe temperature, make the temperature protection control of compressor, and for other purposes.
(14)	R3T	Thermistor (Suction pipe 1)	Used to detect suction pipe temperature, keep the suction superheating degree constant in heating operation, and for other purposes.
(15)	R4T	Thermistor (Heat exchanger deicer)	Used to detect liquid pipe temperature of air heat exchanger, determine defrosting operation, and for other purposes.
(16)	R5T	Thermistor (Suction pipe 2)	Used to the calculation of an internal temperature of compressor, and for other purposes.
(17)	R7T	Thermistor (Liquid pipe)	Used to detect refrigerant overcharge in check operation, and for other purposes.
(18)	R10T	Thermistor (Radiation fin)	Used for outdoor fan speed control and inverter radiation fin temperature control.

RXSQ24/36TAVJU

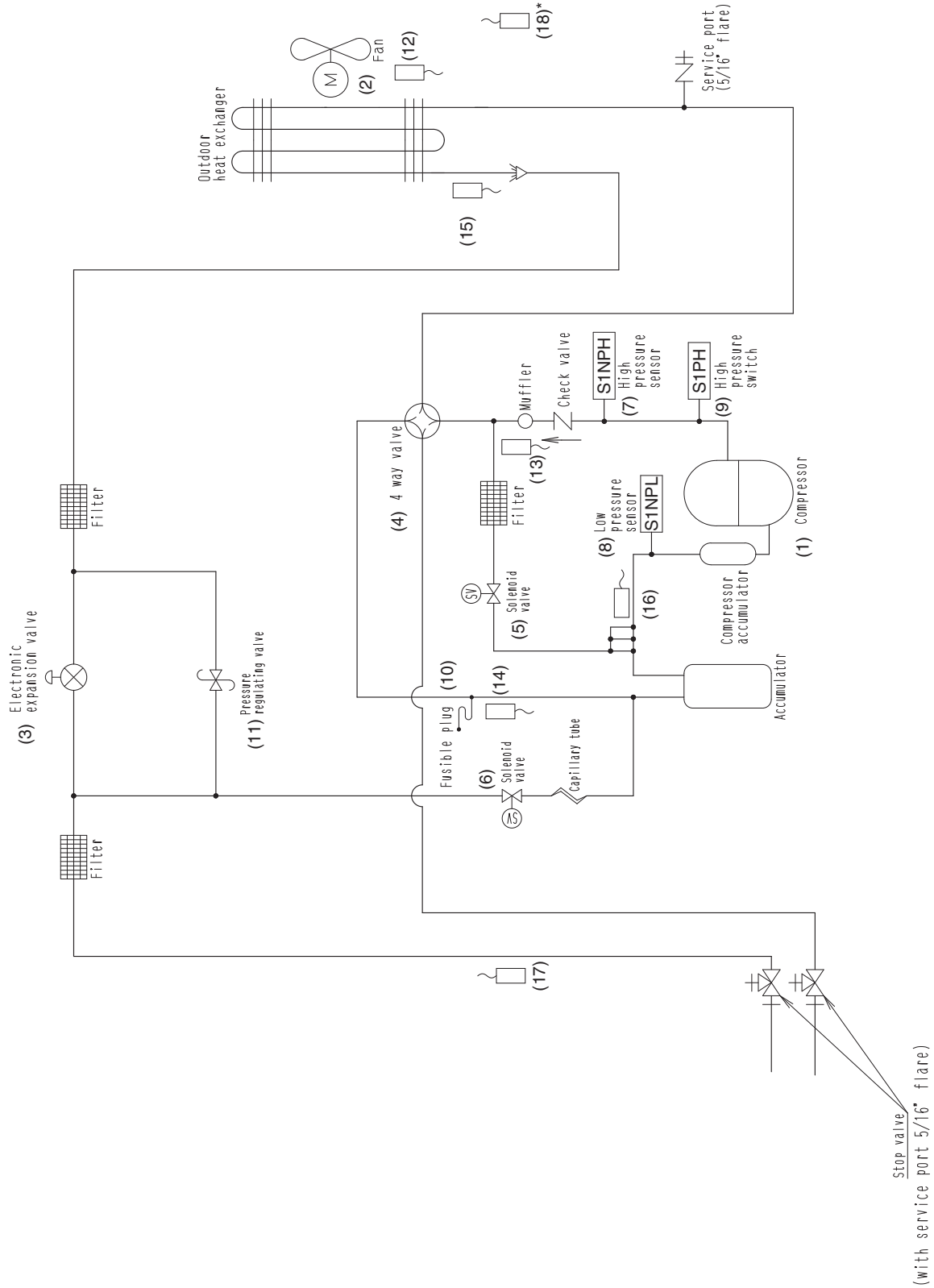

\* The radiation fin thermistor (18) is located near the electrical component box.

C: 3D082498F

RXSQ24/36TAVJUA, RXSQ24/36TBVJUA

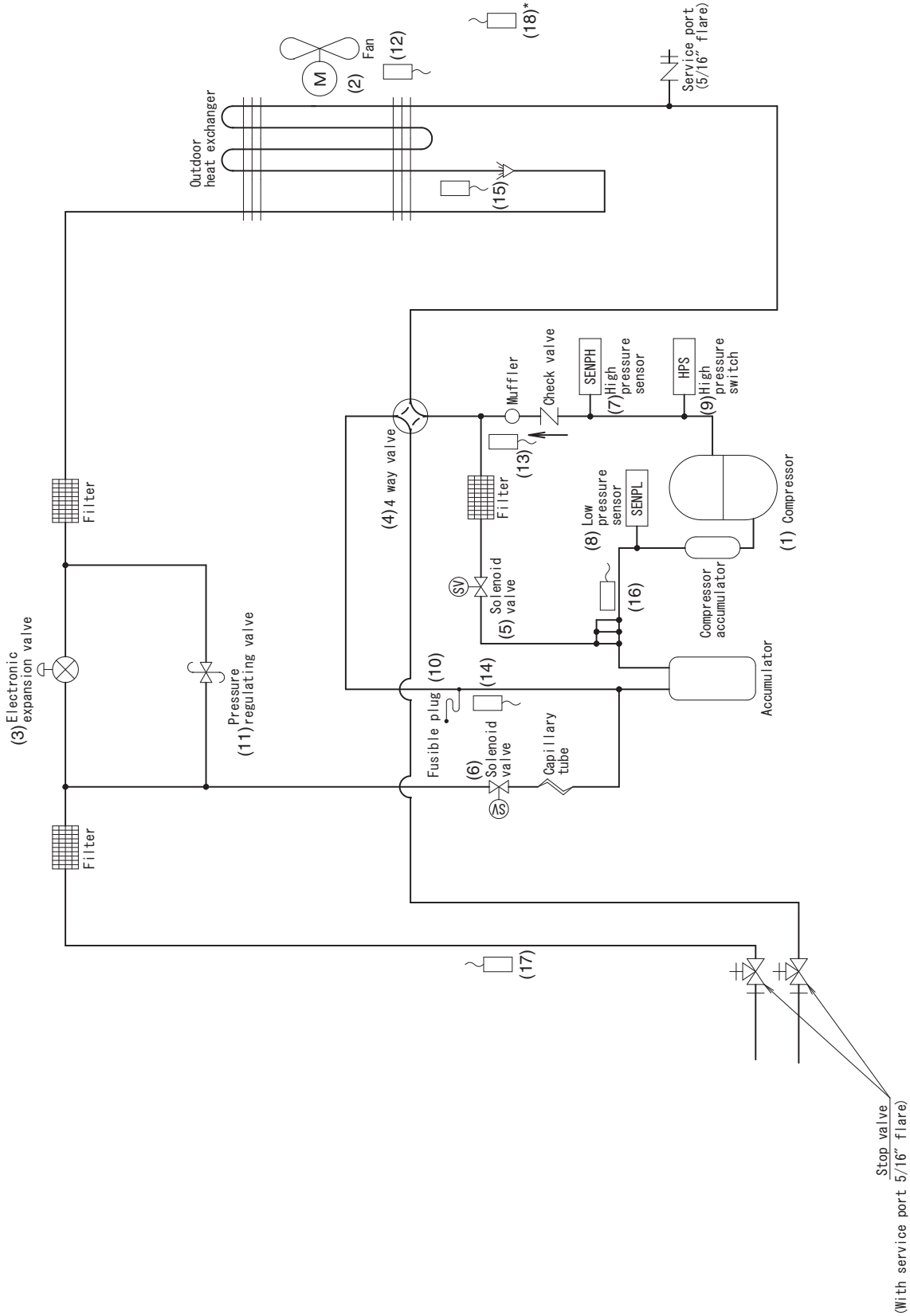

\* The radiation fin thermistor (18) is located near the electrical component box.

C: 3D132130

### 1.1.2 48 Class

No. in piping diagram	Electric symbol	Name	Function
(1)	M1C	Compressor	Compressor is operated on frequencies between 15 rps and 109 rps by using the inverter.
(2)	M1F	Fan motor	Because the system is of an air heat exchange type, the fan is operated at 8-step rotation speed by using the inverter.
(3)	Y1E	Electronic expansion valve (Main)	While in heating operation, PI control is applied to keep the outlet superheating degree of air heat exchanger constant.
(4)	Y1S	Four way valve	Used to switch the operation mode between cooling and heating.
(5)	Y3S	Solenoid valve (Unload circuit)	Used for unloading operation of compressor.
(6)	S1NPH	High pressure sensor	Used to detect high pressure.
(7)	S1NPL	Low pressure sensor	Used to detect low pressure.
(8)	S1PH	High pressure switch	In order to prevent the increase of high pressure when an error occurs, this switch is activated at high pressure of 4.0 MPa (580 psi) or more to stop the compressor operation.
(9)	—	Fusible plug	In order to prevent the increase of pressure when abnormal heating is caused by fire or others, the fusible part of the plug is molten at a temperature of 70 to 75°C (158 to 167°F) to release the pressure into the atmosphere.
(10)	—	Pressure regulating valve (Receiver to discharge pipe)	This valve opens at a pressure of 4.0 MPa (580 psi) for prevention of pressure increase, thus resulting in no damage of functional parts due to the increase of pressure in transportation or storage.
(11)	R1T	Thermistor (Outdoor air)	Used to detect outdoor air temperature, correct discharge pipe temperature, and for other purposes.
(12)	R2T	Thermistor (Discharge pipe)	Used to detect discharge pipe temperature, make the temperature protection control of compressor, and for other purposes.
(13)	R3T	Thermistor (Suction pipe 1)	Used to detect suction pipe temperature, keep the suction superheating degree constant in heating operation, and for other purposes.
(14)	R4T	Thermistor (Heat exchanger deicer)	Used to detect liquid pipe temperature of air heat exchanger, determine defrosting operation, and for other purposes.
(15)	R5T	Thermistor (Suction pipe 2)	Used to the calculation of an internal temperature of compressor, and for other purposes.
(16)	R7T	Thermistor (Liquid pipe)	Used to detect refrigerant overcharge in check operation, and for other purposes.
(17)	FINTH	Thermistor (Radiation fin)	Used for outdoor fan speed control and inverter radiation fin temperature control.



RXSQ48TAVJU

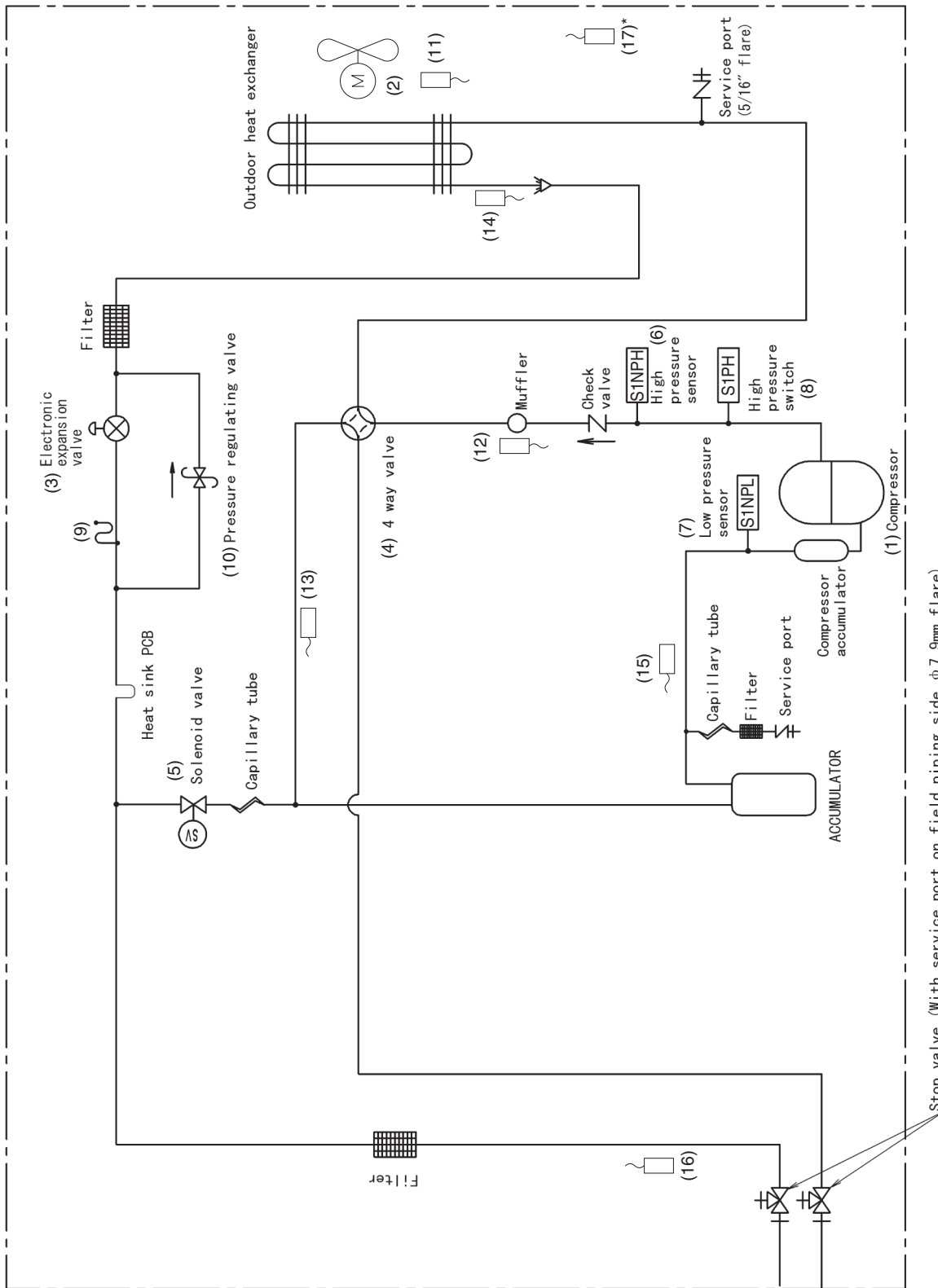

Stop valve (With service port on field piping side  $\phi$  7.9mm flare)

\* The radiation fin thermistor (17) is located near the electrical component box.

C:3D088594A

RXSQ48TAVJUA, RXSQ48TBVJUA

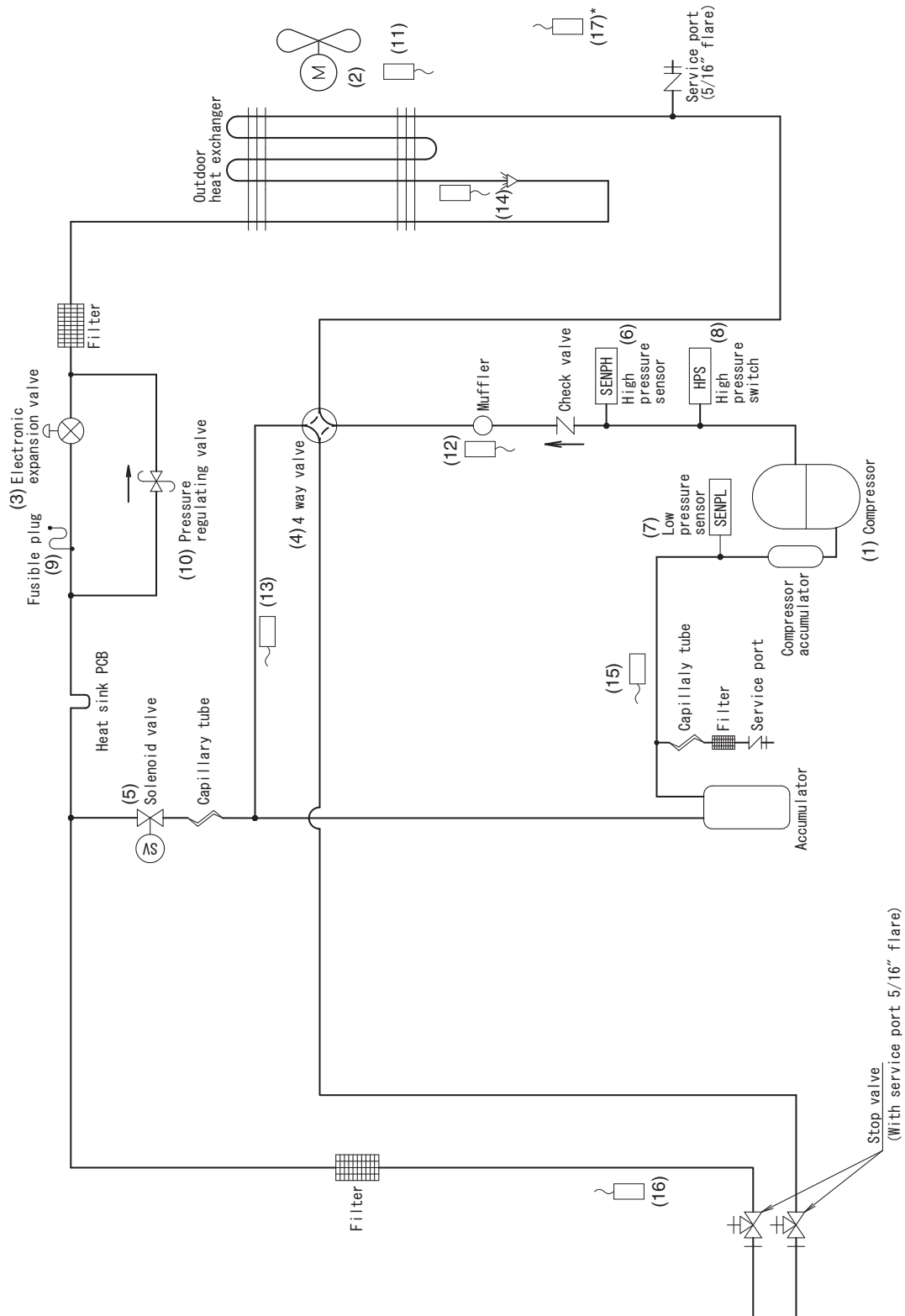

\* The radiation fin thermistor (17) is located near the electrical component box.

C: 3D132131

### 1.1.3 60 Class

No. in piping diagram	Electric symbol	Name	Function
(1)	M1C	Compressor	Compressor is operated on frequencies between 15 rps and 109 rps by using the inverter.
(2)	M1F M2F	Fan motor	Because the system is of an air heat exchange type, the fan is operated at 8-step rotation speed by using the inverter.
(3)	Y1E	Electronic expansion valve (Main)	While in heating operation, PI control is applied to keep the outlet superheating degree of air heat exchanger constant.
(4)	Y3E	Electronic expansion valve (Subcooling)	PI control is applied to keep the outlet superheating degree of subcooling heat exchanger constant.
(5)	Y1S	Four way valve	Used to switch the operation mode between cooling and heating.
(6)	S1NPH	High pressure sensor	Used to detect high pressure.
(7)	S1NPL	Low pressure sensor	Used to detect low pressure.
(8)	S1PH	High pressure switch	In order to prevent the increase of high pressure when an error occurs, this switch is activated at high pressure of 4.0 MPa (580 psi) or more to stop the compressor operation.
(9)	—	Fusible plug	In order to prevent the increase of pressure when abnormal heating is caused by fire or others, the fusible part of the plug is molten at a temperature of 70 to 75°C (158 to 167°F) to release the pressure into the atmosphere.
(10)	—	Pressure regulating valve (Receiver to discharge pipe)	This valve opens at a pressure of 4.0 MPa (580 psi) for prevention of pressure increase, thus resulting in no damage of functional parts due to the increase of pressure in transportation or storage.
(11)	R1T	Thermistor (Outdoor air)	Used to detect outdoor air temperature, correct discharge pipe temperature, and for other purposes.
(12)	R2T	Thermistor (Discharge pipe)	Used to detect discharge pipe temperature, make the temperature protection control of compressor, and for other purposes.
(13)	R3T	Thermistor (Suction pipe 1)	Used to detect suction pipe temperature, keep the suction superheating degree constant in heating operation, and for other purposes.
(14)	R4T	Thermistor (Heat exchanger deicer)	Used to detect liquid pipe temperature of air heat exchanger, determine defrosting operation, and for other purposes.
(15)	R5T	Thermistor (Suction pipe 2)	Used to the calculation of an internal temperature of compressor, and for other purposes.
(16)	R6T	Thermistor (Subcooling heat exchanger gas pipe)	Used to detect gas pipe temperature on the evaporation side of subcooling heat exchanger, keep the superheating degree at the subcooling heat exchanger constant, and for other purposes.
(17)	R7T	Thermistor (Liquid pipe)	Used to detect refrigerant overcharge in check operation, and for other purposes.
(18)	FINTH	Thermistor (Radiation fin)	Used for outdoor fan speed control and inverter radiation fin temperature control.

RXSQ60TAVJU

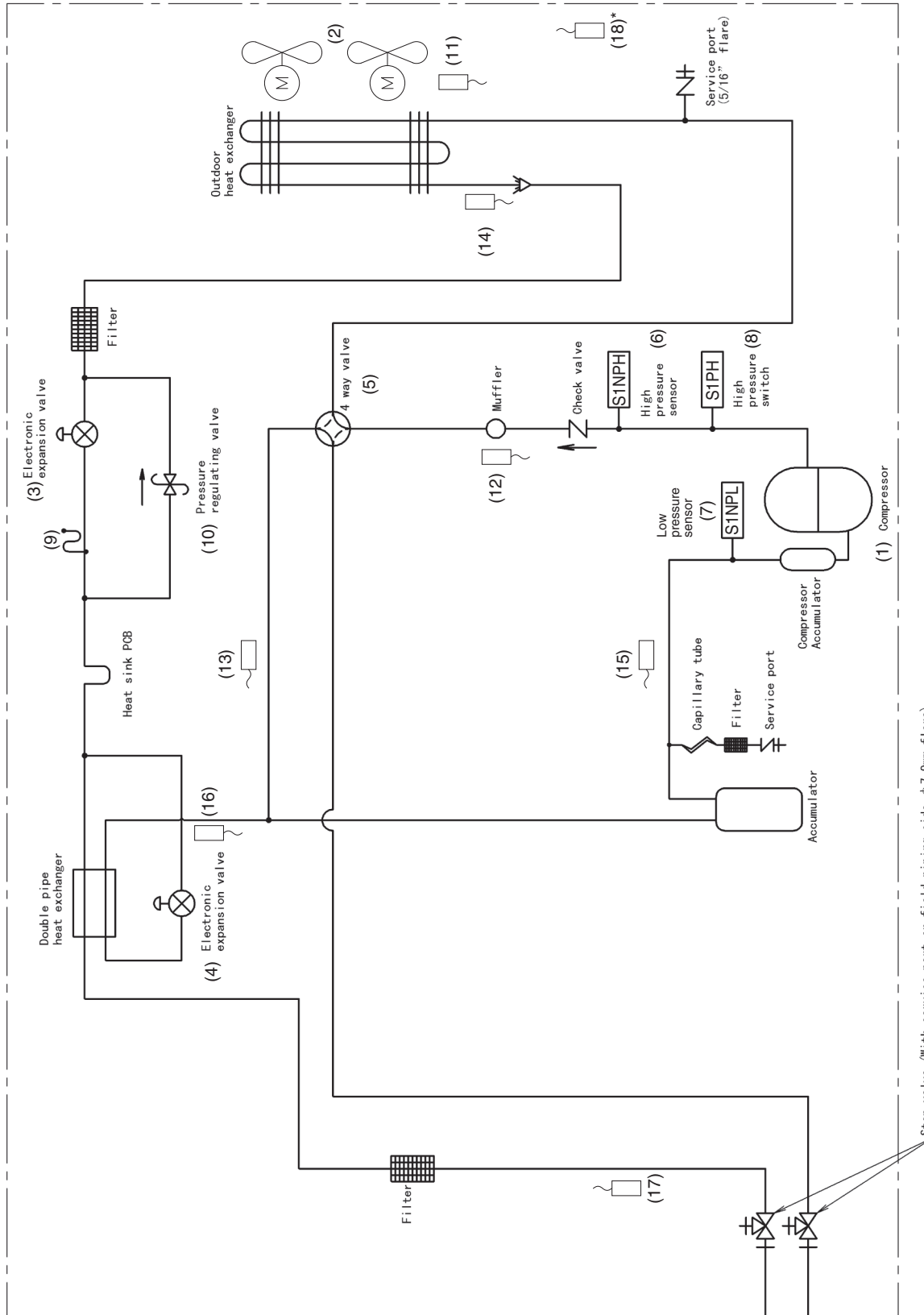

\* The radiation fin thermistor (18) is located near the electrical component box.

C: 3D088595A

Stop valve (With service port on field piping side φ7.9mm flare).

RXSQ60TAVJUA, RXSQ60TBVJUA

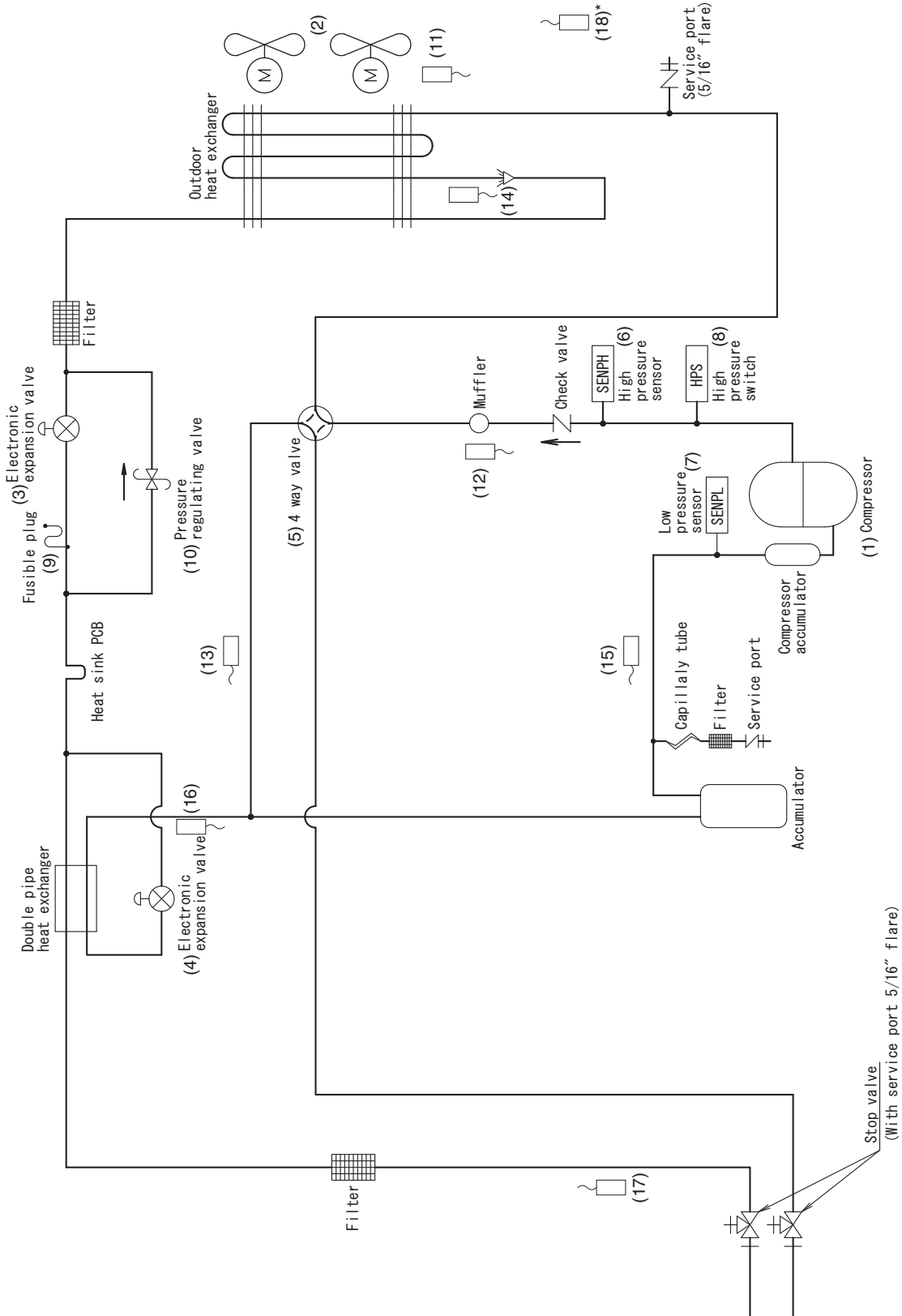

\* The radiation fin thermistor (18) is located near the electrical component box.

C: 3D132132

## 1.2 Indoor Unit

No. in piping diagram	Name	Symbol			Function
		Except FXMQ-PB, FXTQ-TA, CXTQ-TA	FXMQ-PB	FXTQ-TA CXTQ-TA	
(1)	Electronic expansion valve	Y1E	Y1E	Y1E	Used for gas superheating degree control while in cooling or subcooling degree control while in heating.
(2)	Suction air thermistor	R1T	R1T	R1T (*1)	Used for thermostat control.
(3)	Liquid pipe thermistor	R2T	R2T	R2T	Used for gas superheating degree control while in cooling or subcooling degree control while in heating.
(4)	Gas pipe thermistor	R3T	R3T	R3T	Used for gas superheating degree control while in cooling.
(5)	Discharge air thermistor	—	R4T	—	Used for discharge air temperature control.

\*1. R1T is for remote controller thermistor or optional remote sensor.

### ■ FXFQ-T, FXFQ-P, FXHQ-M

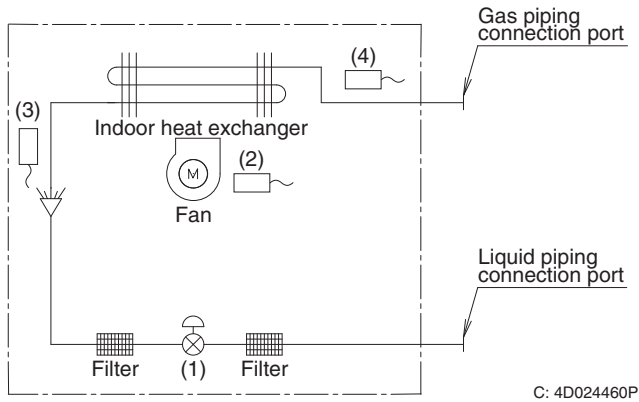

### ■ FXZQ-TA

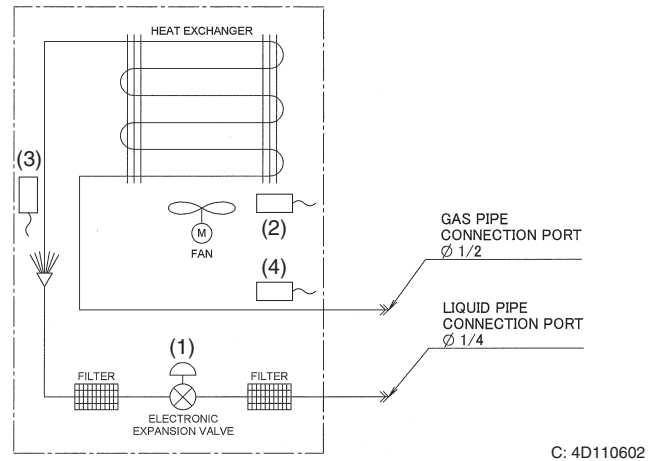

### ■ FXZQ-TB

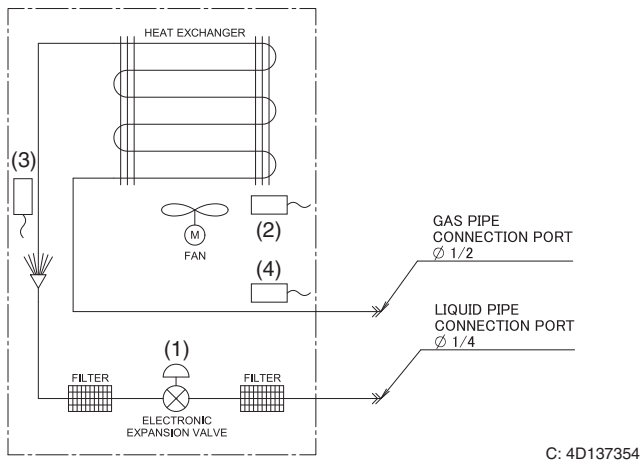

### ■ FXZQ-M

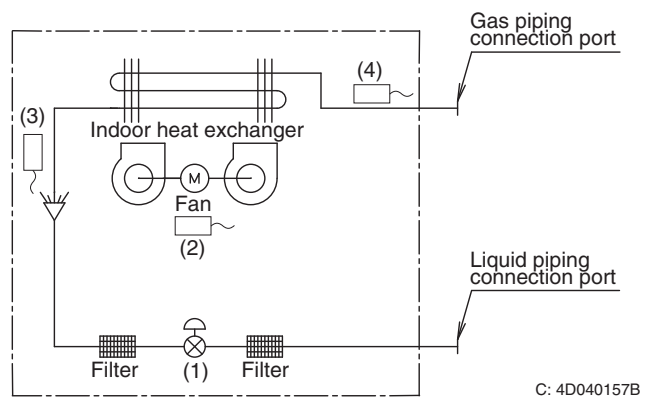

■ FXUQ-P, FXEQ-P, FXSQ-TA, FXAQ-P, FXLQ-M, FXNQ-M

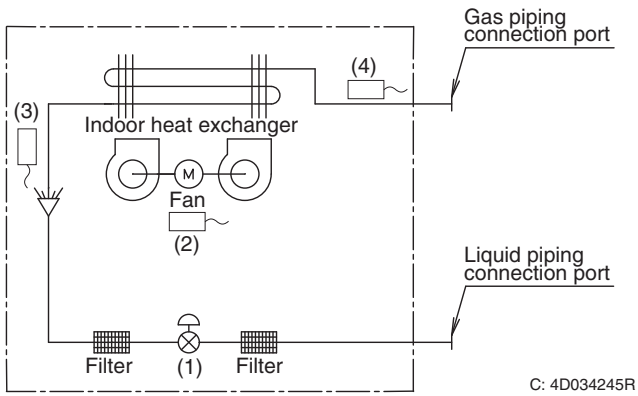

■ FXUQ-PA

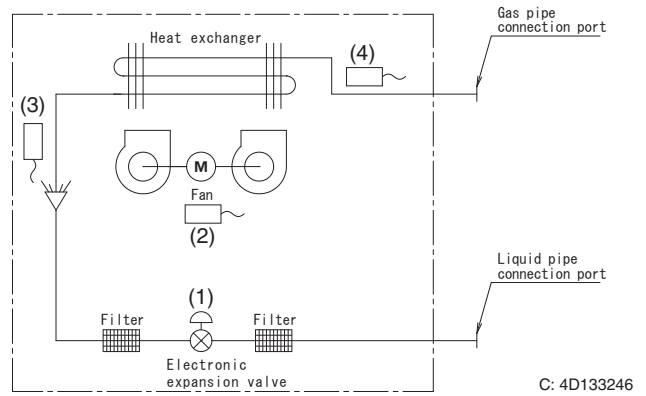

■ FXSQ-TB, FXMQ-TB

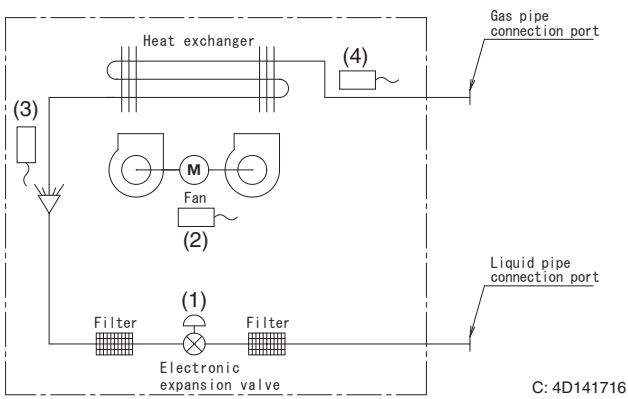

■ FXDQ-M

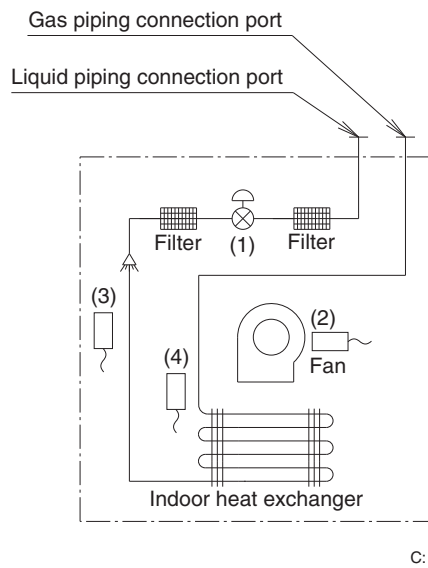

■ FXMQ-PB

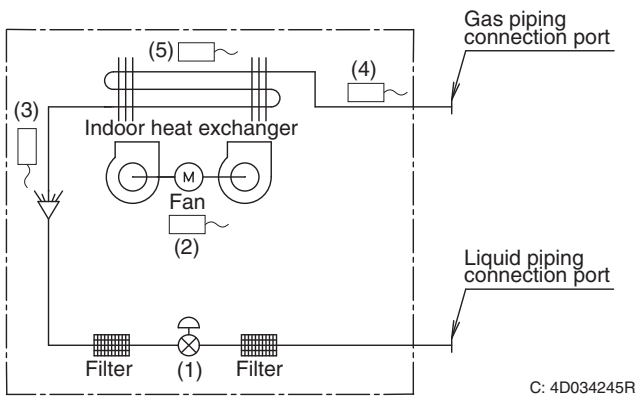

■ FXTQ-TA

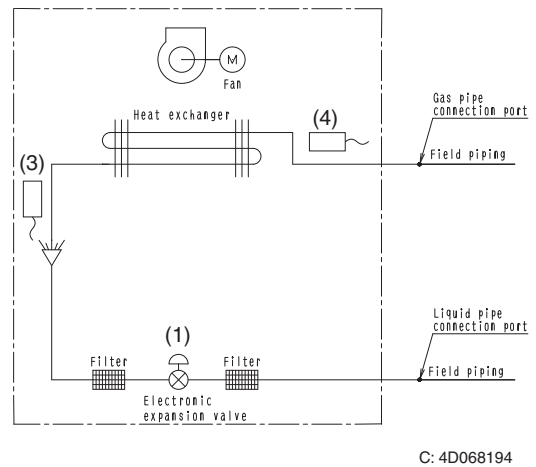

■ CXTQ-TA

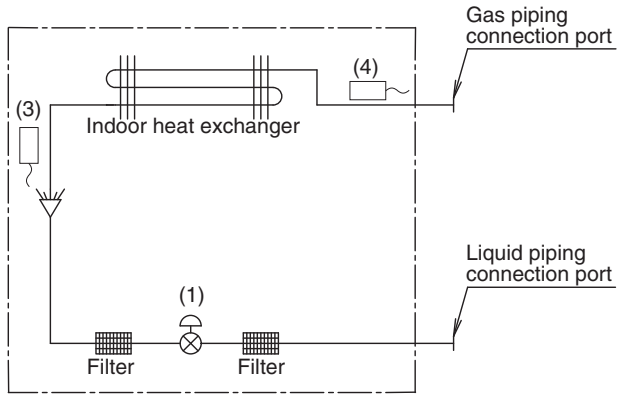



## 1.3 Outdoor-Air Processing Unit

FXMQ48/72MFVJU

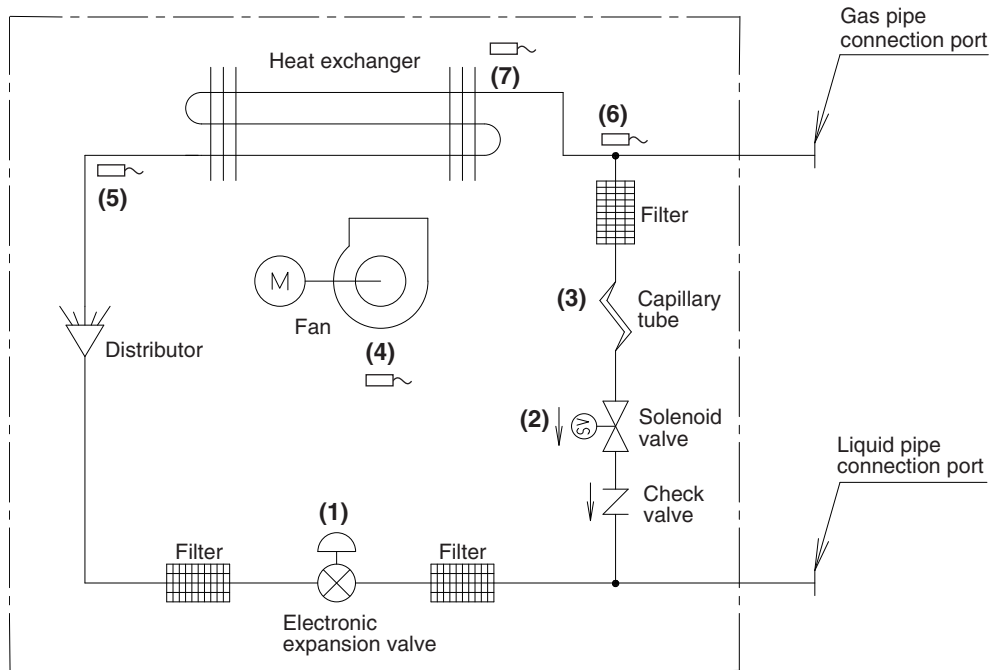

C: 4D018650D

No. in piping diagram	Electric symbol	Name	Function
(1)	Y1E	Electronic expansion valve	Used to control the flow rate of refrigerant, and make the SH control (*1) while in cooling.
(2)	Y1S	Solenoid valve	Used to bypass hot gas while in heating with thermostat OFF. Closed while in cooling.
(3)	—	Capillary tube	Used to reduce pressure from high to low in bypassing hot gas.
(4)	R1T	Suction air thermistor	Used to turn ON or OFF the thermostat.
(5)	R2T	Liquid pipe thermistor	Used to control the opening degree of electronic expansion valve under the SC control (*2).
(6)	R3T	Gas pipe thermistor	Used to control the opening degree of electronic expansion valve under the SH control.
(7)	R4T	Discharge air thermistor	Used to control the electronic expansion valve opening and thermostat ON/OFF so as to keep the discharge air temperature at the set temperature.



### Note(s)

\*1. SH control: Superheating control of heat exchanger outlet

\*2. SC control: Subcooling control of heat exchanger outlet

## 2. Functional Parts Layout

### 2.1 RXSQ24/36TAVJU

#### Top view

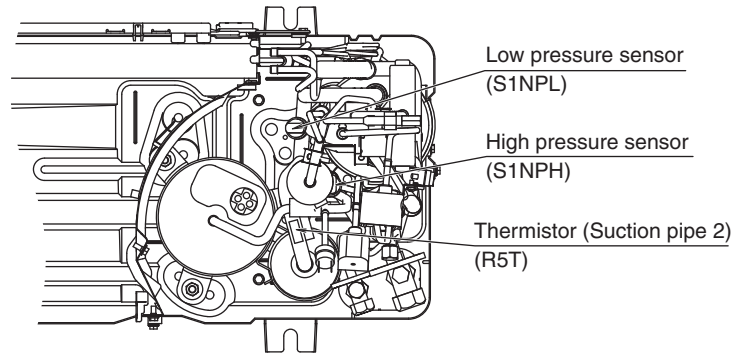

#### Front view

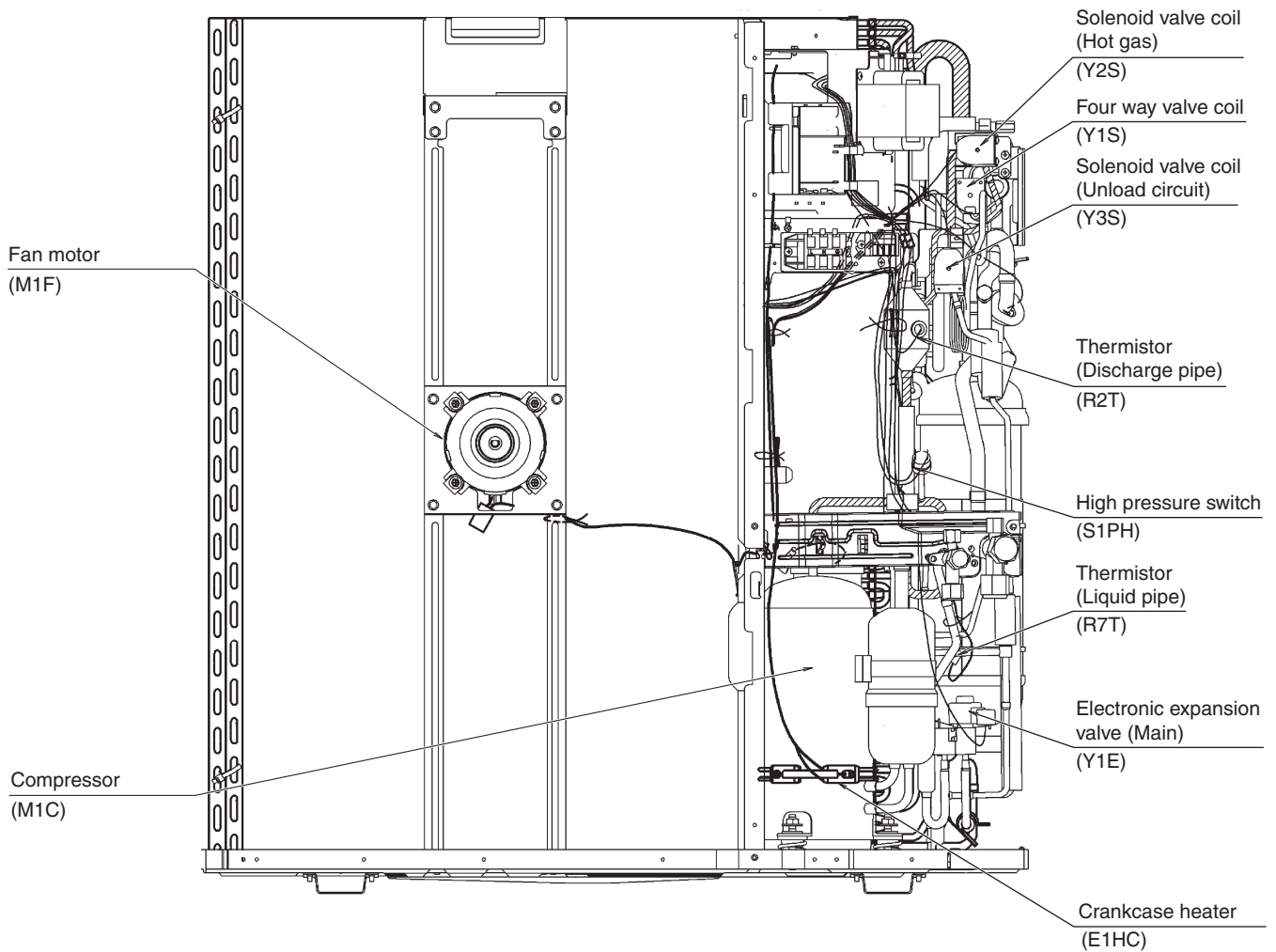

C: 1P342997N

Side view

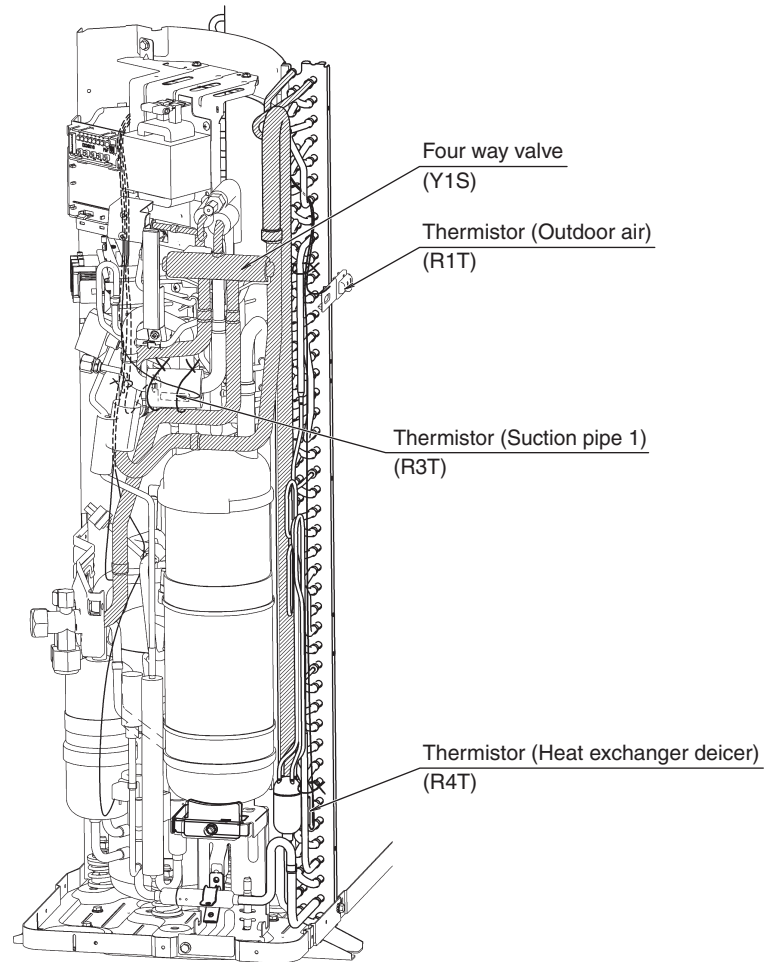

C: 1P342997N

## 2.2 RXSQ24/36TAVJUA, RXSQ24/36TBVJUA

### Top view

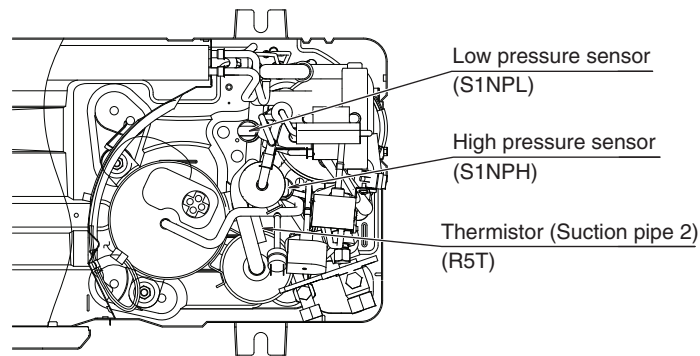

### Front view

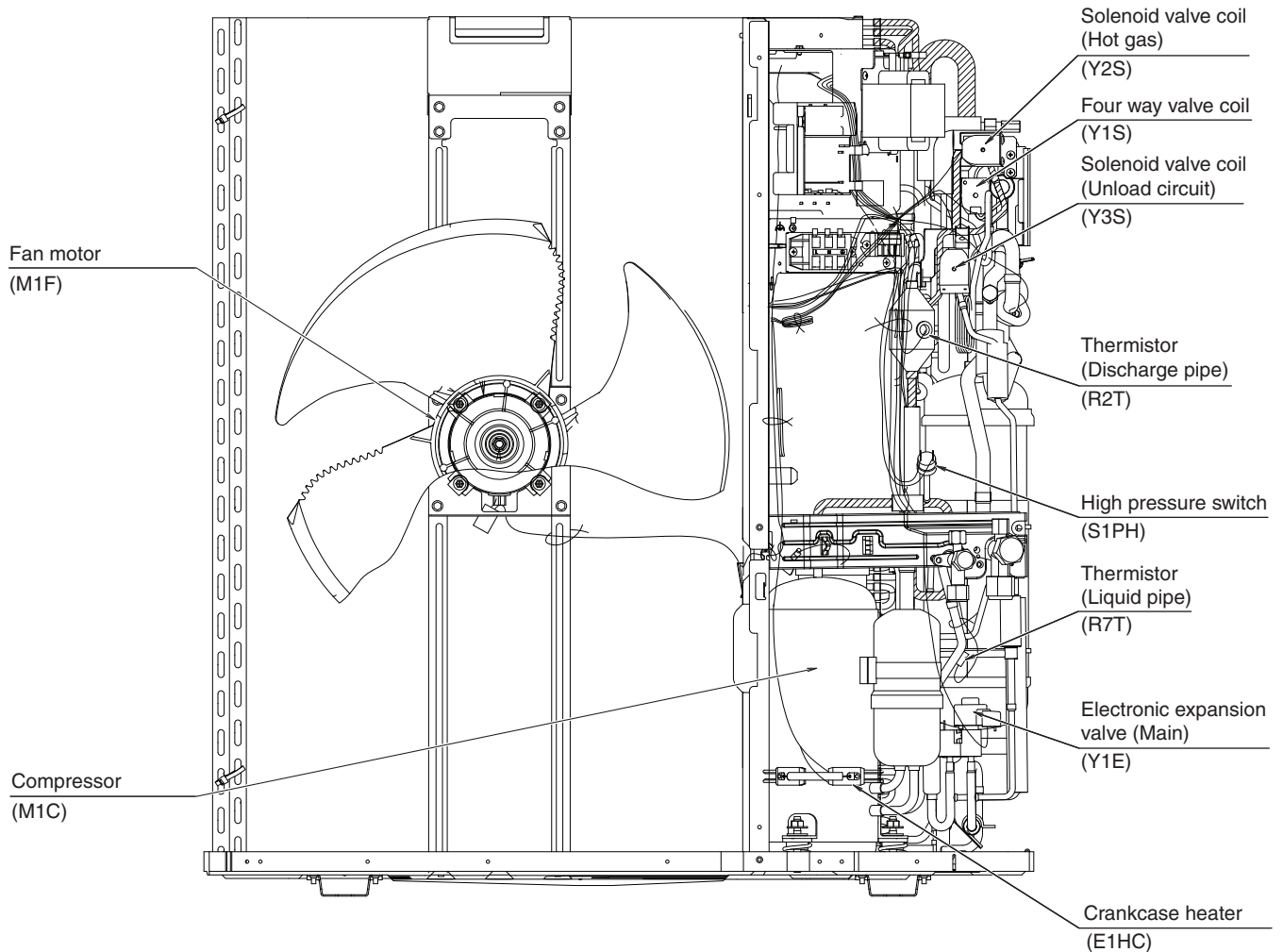

C: 1P589934F

## Side view

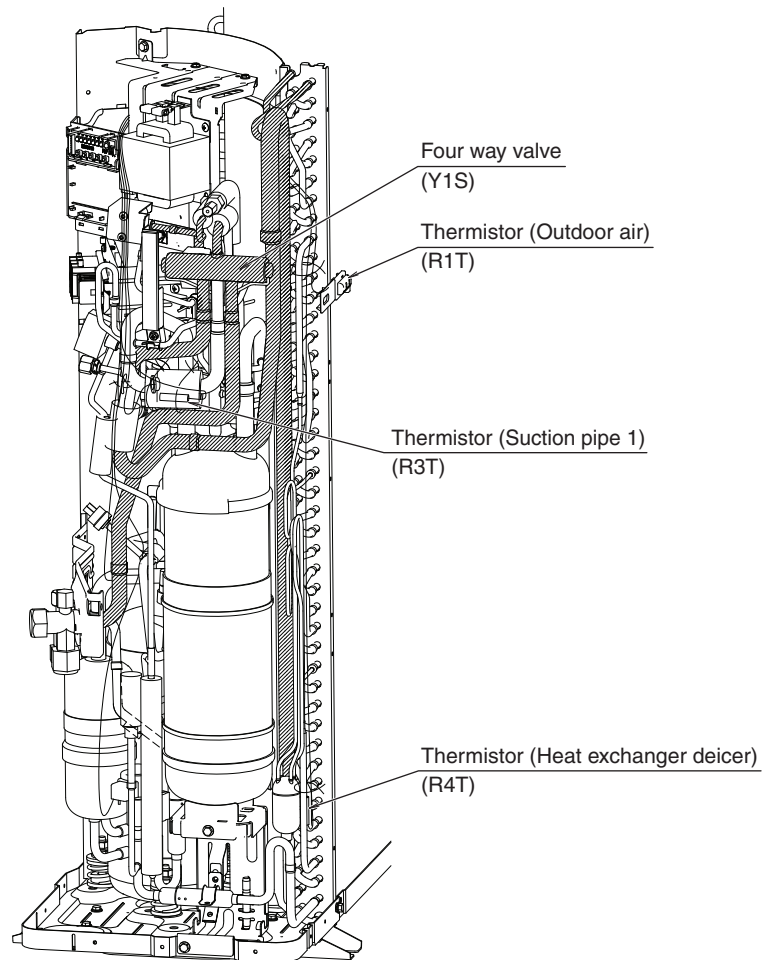

C: 1P589934F

## 2.3 RXSQ48TAVJU

Front view

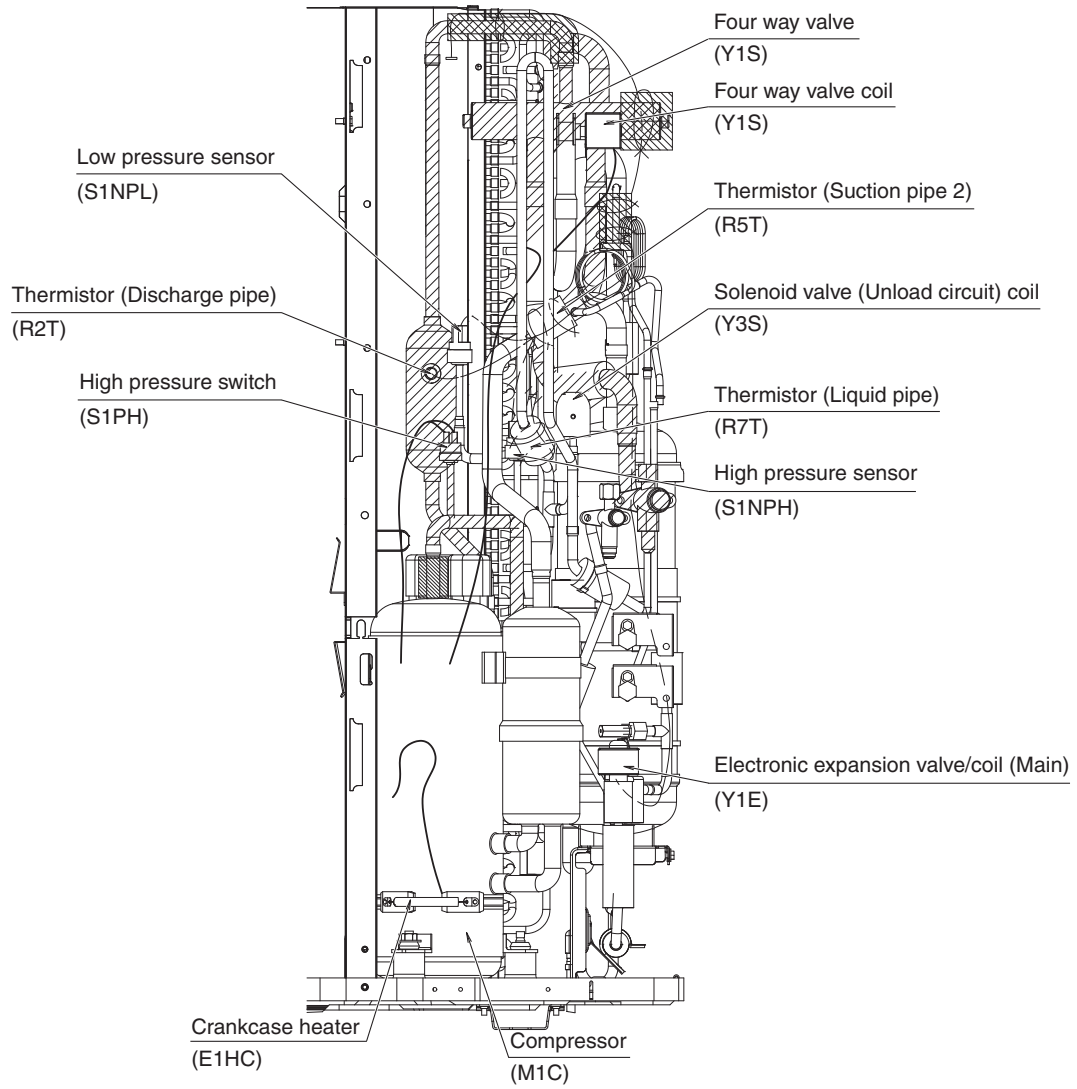

C: 1P374828V

Side view

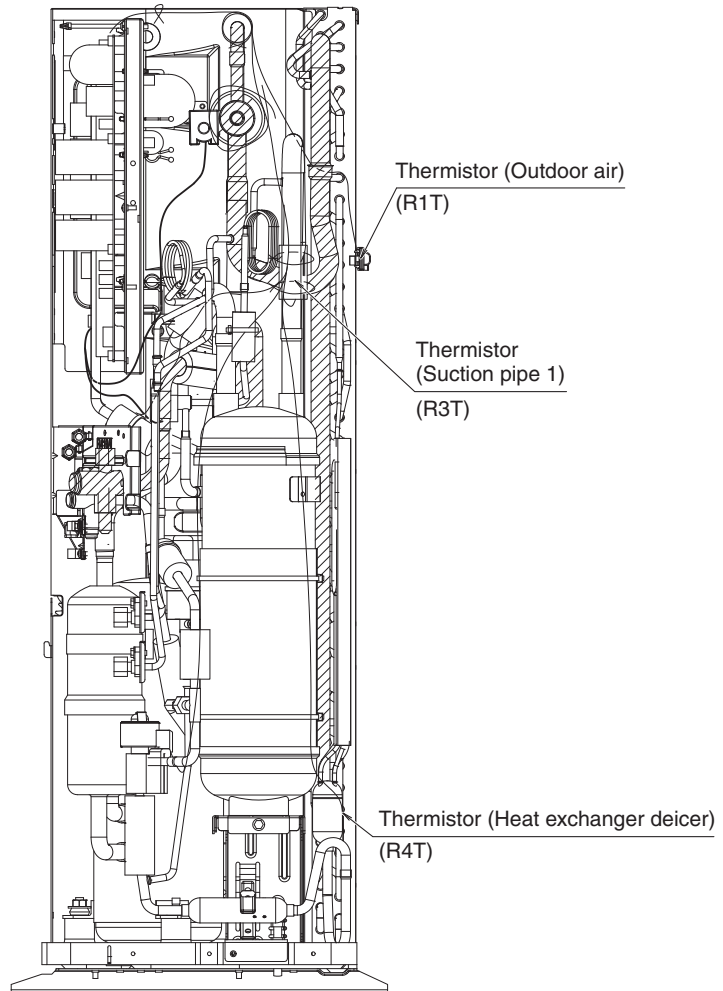

C: 1P374828V

## 2.4 RXSQ48TAVJUA, RXSQ48TBVJUA

Front view

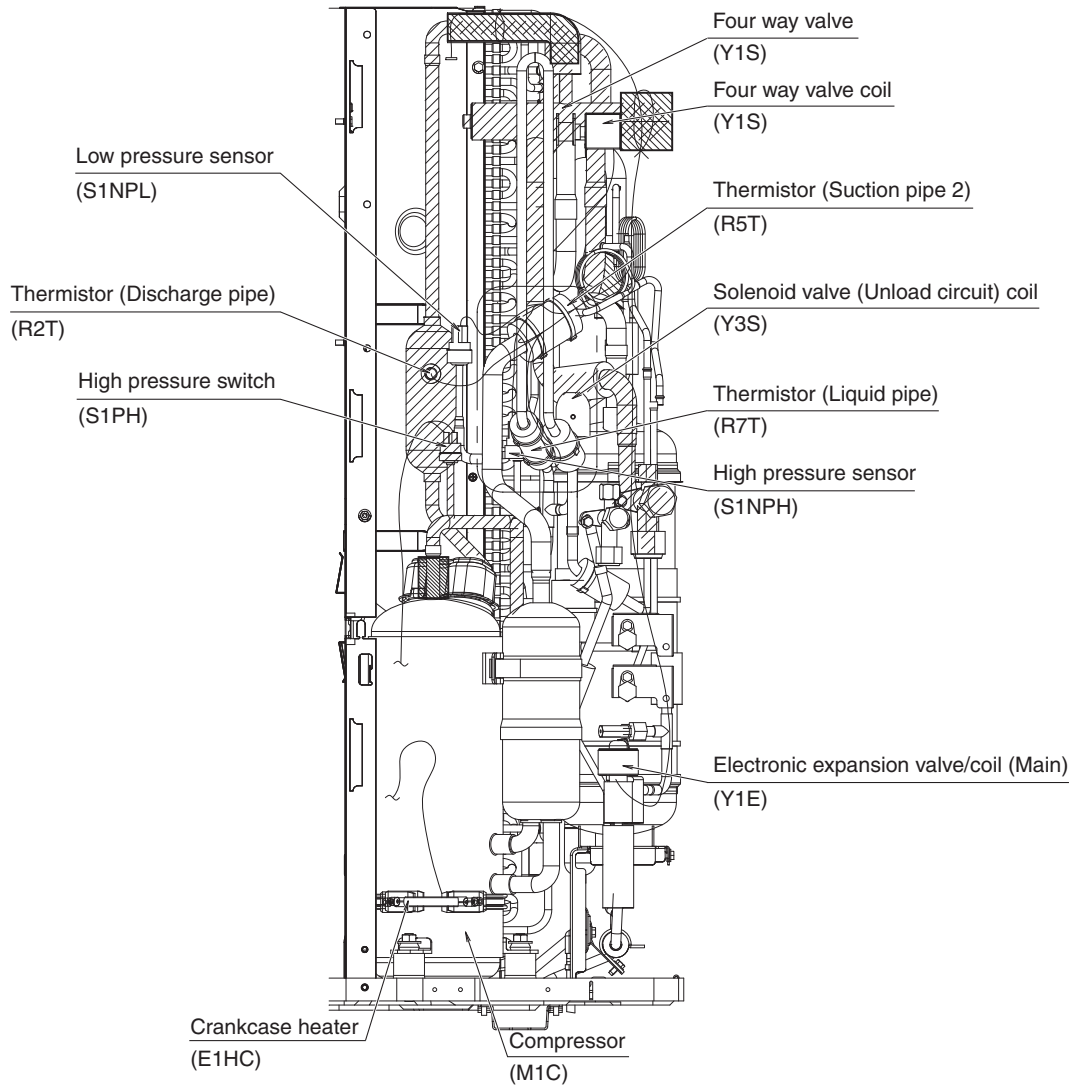

C: 1P589935E



## Side view

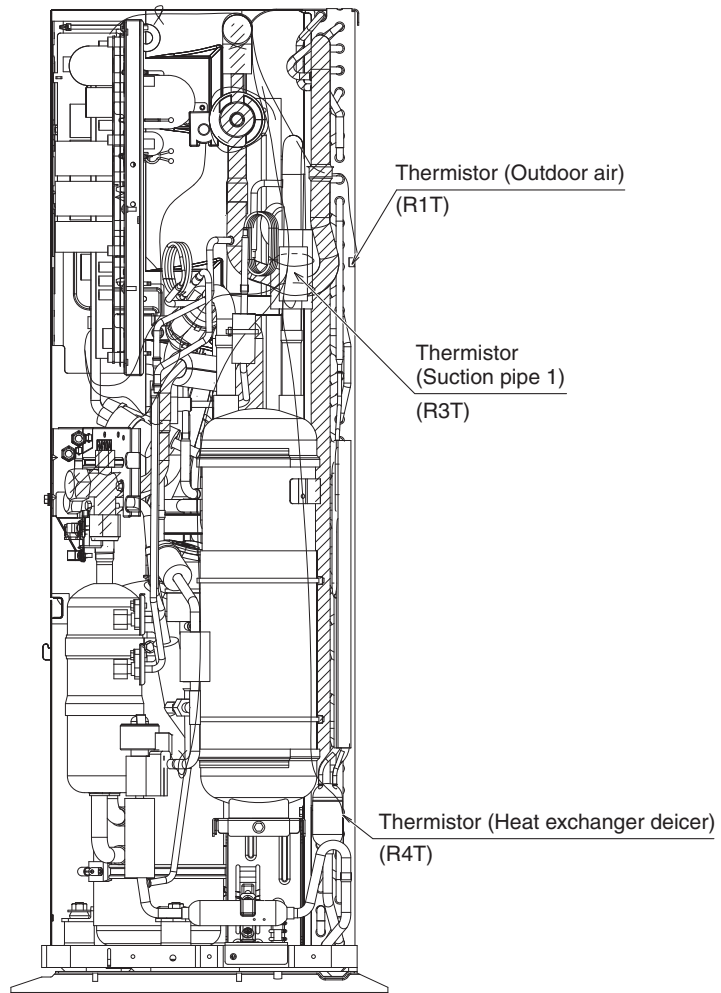

C: 1P589935E

## 2.5 RXSQ60TAVJU

Front view

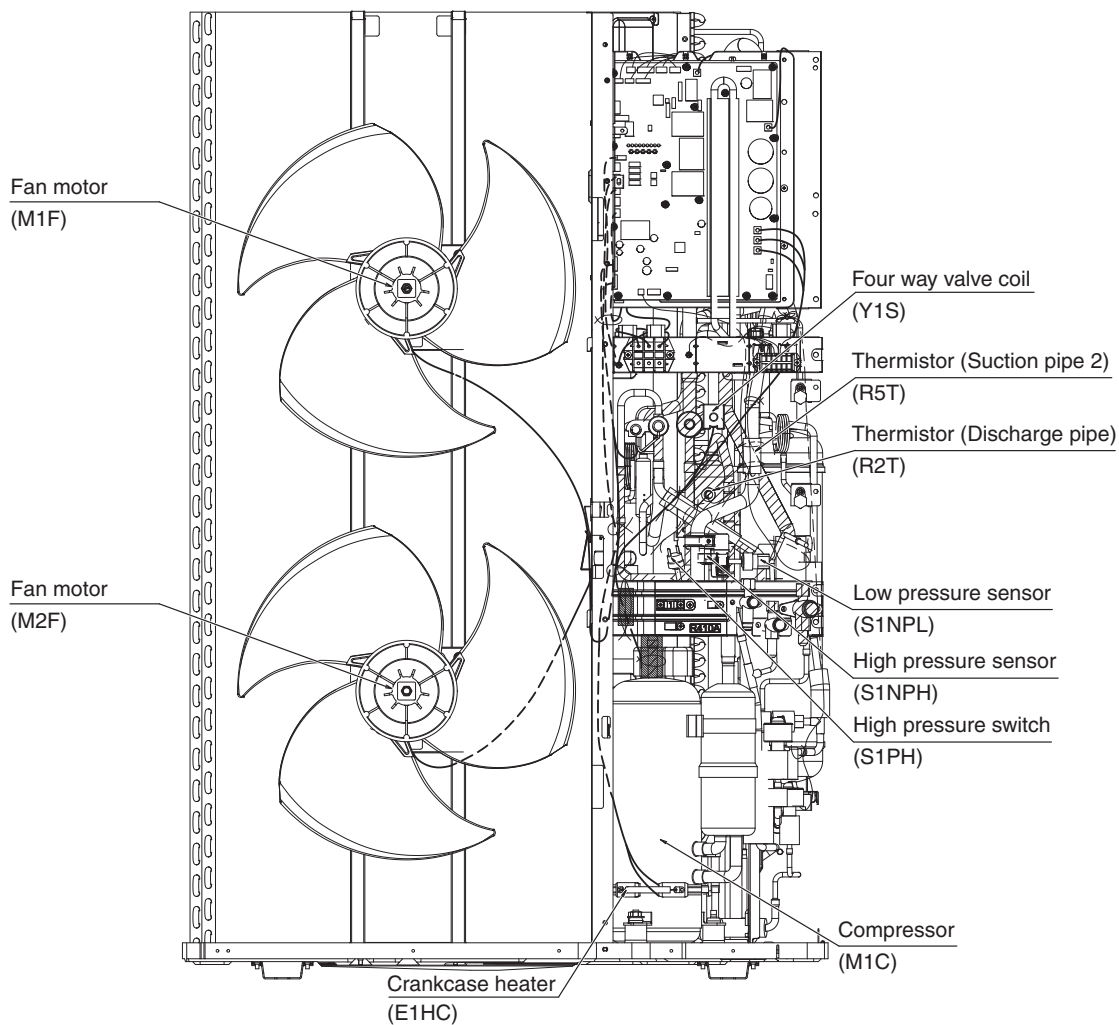

C: 1P441643P

## Side view

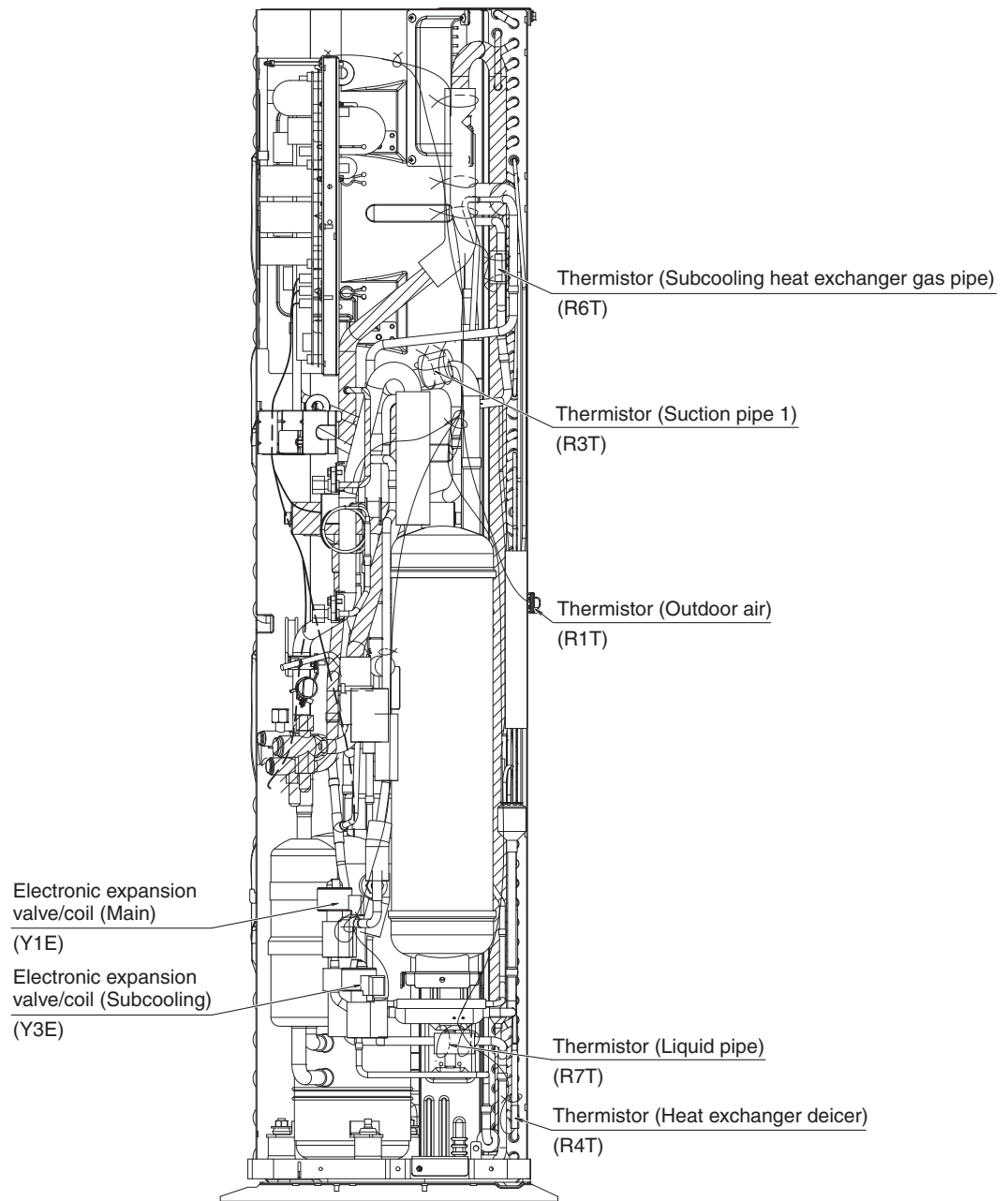

C: 1P441643P

## 2.6 RXSQ60TAVJUA, RXSQ60TBVJUA

Front view

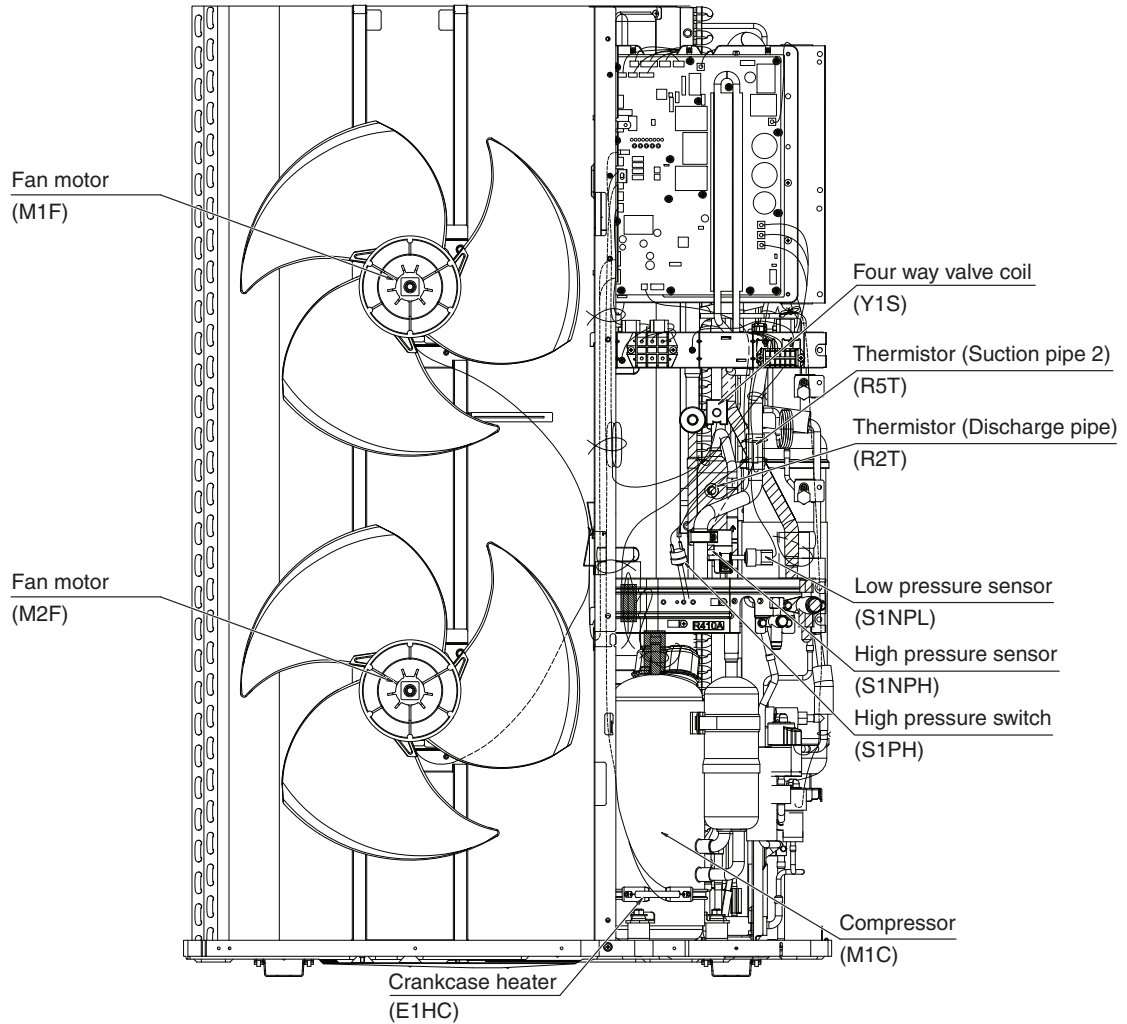

C: 1P589937E

## Side view

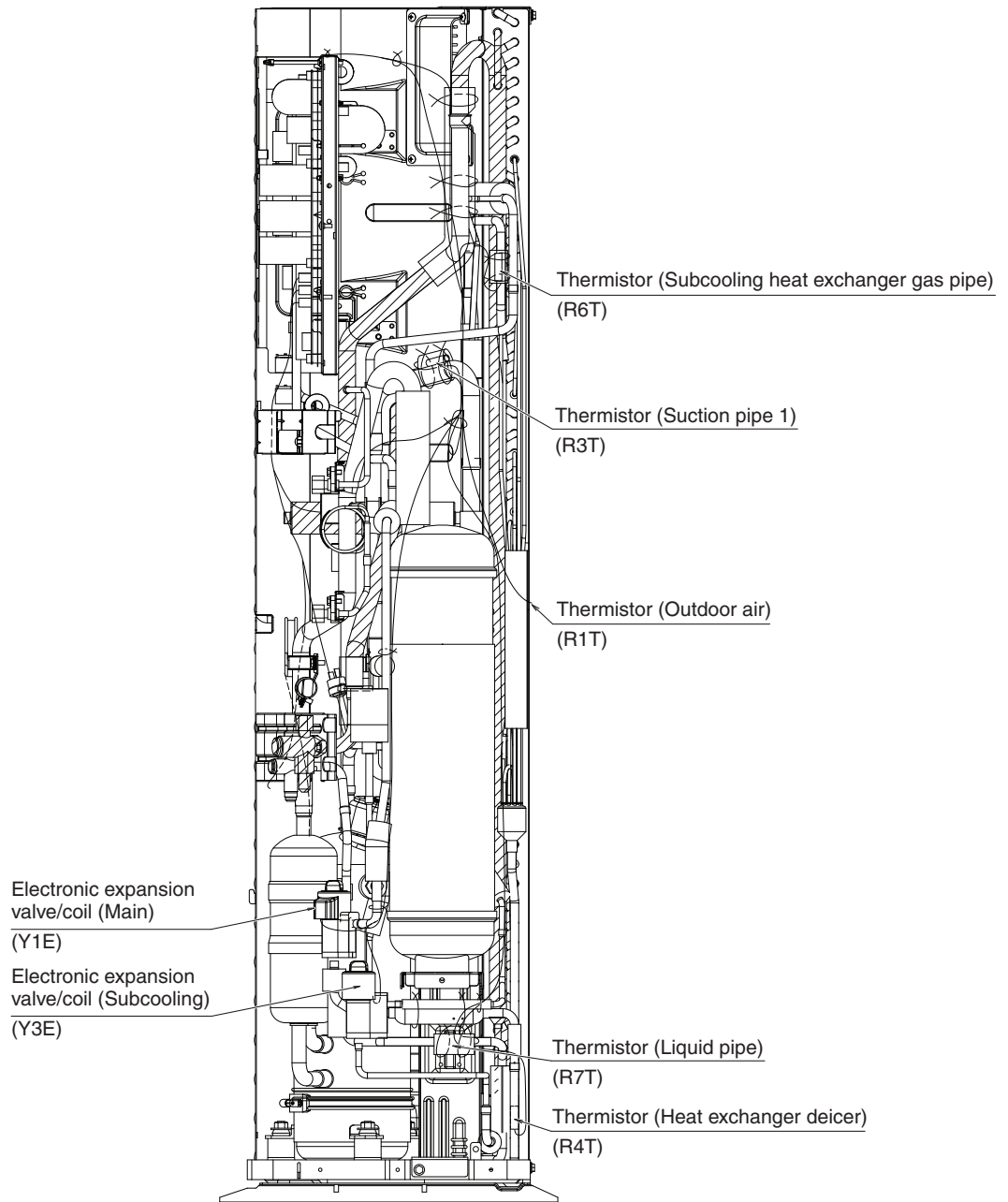

C: 1P589937E

---

# Part 3

## Remote Controller

1. Applicable Models .....	48
2. Names and Functions .....	49
2.1 BRC1E73 .....	49
2.2 BRC1H71W .....	52
2.3 Wireless Remote Controller .....	60
3. Main/Sub Setting .....	61
3.1 BRC1E73 .....	61
3.2 BRC1H71W .....	63
3.3 When Wireless Remote Controller is Used Together .....	65
4. Address Setting for Wireless Remote Controller .....	66
5. Centralized Control Group No. Setting .....	68
5.1 BRC1E73 .....	68
5.2 BRC1H71W .....	70
5.3 Wireless Remote Controller .....	70
5.4 Group No. Setting Example .....	71
6. Service Settings Menu, Maintenance Menu .....	72
6.1 BRC1E73 .....	72
7. Administrator Menu, Installer Menu .....	76
7.1 BRC1H71W .....	76

# 1. Applicable Models

Series	Wired remote controller		Wireless remote controller
	Navigation	Madoka	
FXFQ-T	BRC1E73	BRC1H71W	—
FXFQ-P			—
FXZQ-TA			BRC082A42W (for BYFQ60C3W1W) BRC082A42S (for BYFQ60C3W1S) BRC082A41W (for BYFQ60B3W1)
FXZQ-TB			BRC082A42W (for BYFQ60C3W2W) BRC082A41W (for BYFQ60B3W1)
FXZQ-M			BRC7E830
FXUQ-P			—
FXUQ-PA			—
FXEQ-P			—
FXDQ-M			BRC4C82
FXSQ-TA			BRC082A43
FXSQ-TB			—
FXMQ-PB			BRC4C82 (Fan: 2 steps) BRC082A43 (Fan: 3 steps)
FXMQ-TB			BRC082A43
FXHQ-M			BRC7E83
FXAQ-P			BRC7E818
FXLQ-M			—
FXNQ-M			—
FXTQ-TA			—
CXTQ-TA			BRC4C82
FXMQ-MF			—
VAM-G	—		

## 2. Names and Functions

### 2.1 BRC1E73

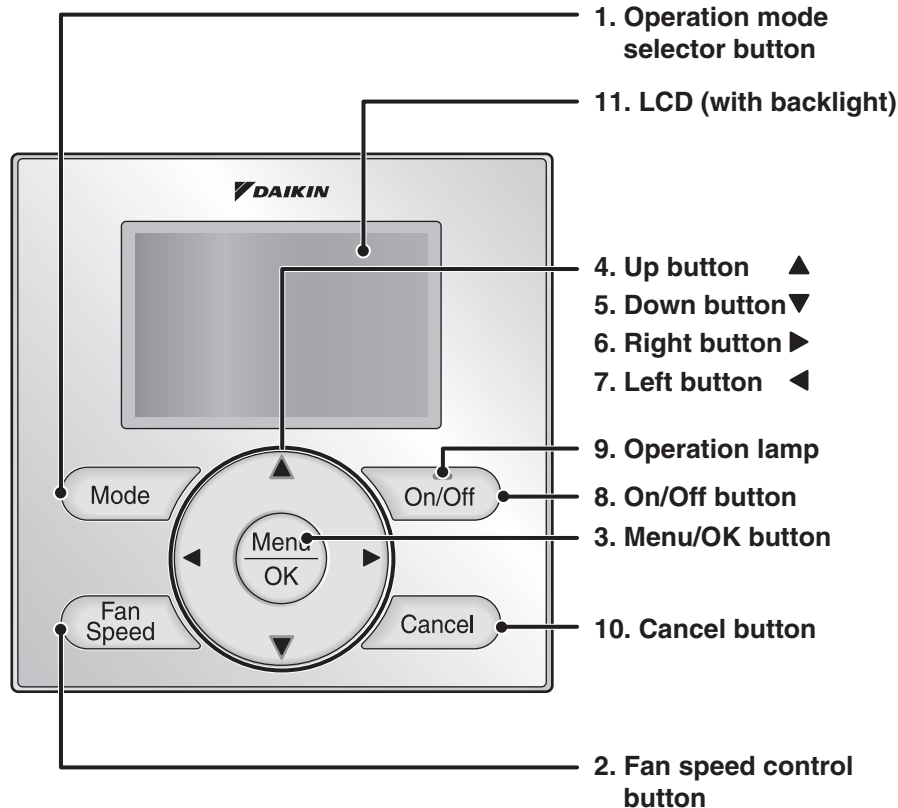

Functions other than basic operation items (i.e., On/Off, Operation Mode, Fan Speed, and Setpoint) are set from the menu screen.



#### Note(s)

- Do not install the remote controller in places exposed to direct sunlight, the LCD will be damaged.
- Do not pull or twist the remote controller cord, the remote controller may be damaged.
- Do not use objects with sharp ends to press the buttons on the remote controller damage may result.

#### 1. Operation mode selector button

- Press this button to select the operation mode of your preference.
- \* Available modes vary with the indoor unit model.

#### 2. Fan speed control button

- Press this button to select the fan speed of your preference.
- \* Available fan speeds vary with the indoor unit model.

#### 3. Menu/OK button

- Used to enter the main menu.
- Used to enter the selected item.



**4. Up button ▲**

- Used to raise the setpoint.
- The item above the current selection will be highlighted. (The highlighted items will be scrolled continuously when the button is continuously pressed.)
- Used to change the selected item.

**5. Down button ▼**

- Used to lower the setpoint.
- The item below the current selection will be highlighted. (The highlighted items will be scrolled continuously when the button is continuously pressed.)
- Used to change the selected item.

**6. Right button ►**

- Used to highlight the next items on the right-hand side.
- Each screen is scrolled in the right-hand direction.

**7. Left button ◀**

- Used to highlight the next items on the left-hand side.
- Each screen is scrolled in the left-hand direction.

**8. On/Off button**

- Press this button and system will start.
- Press this button again to stop the system.

**9. Operation lamp**

- This lamp illuminates solid green during normal operation.
- This lamp blinks if an error occurs.

**10. Cancel button**

- Used to return to the previous screen.

**11. LCD (with backlight)**

- The backlight will be illuminated for approximately 30 seconds by pressing any button.
- If two remote controllers are used to control a single indoor unit, only the controller accessed first will have backlight functionality.



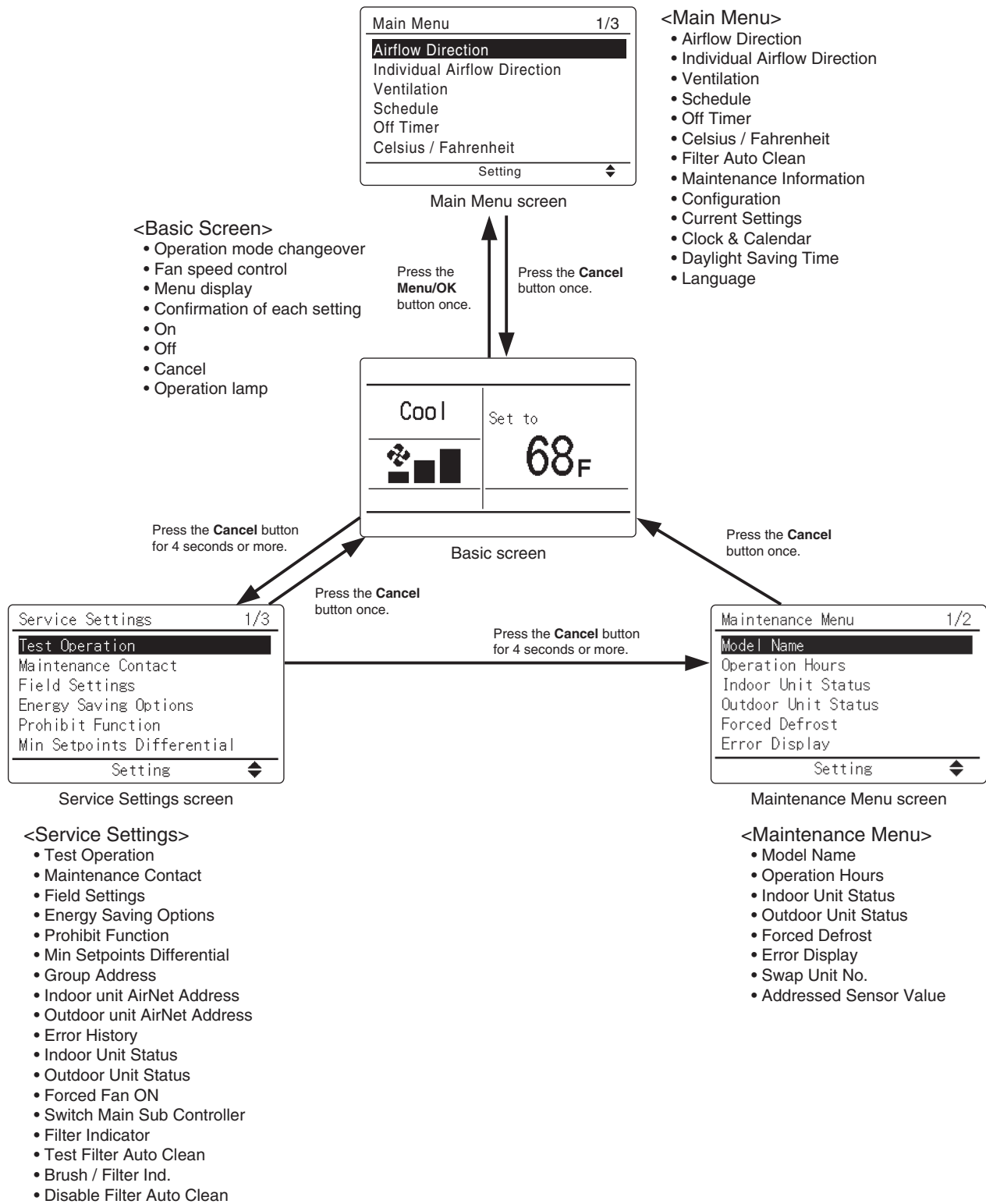

Service Check Function

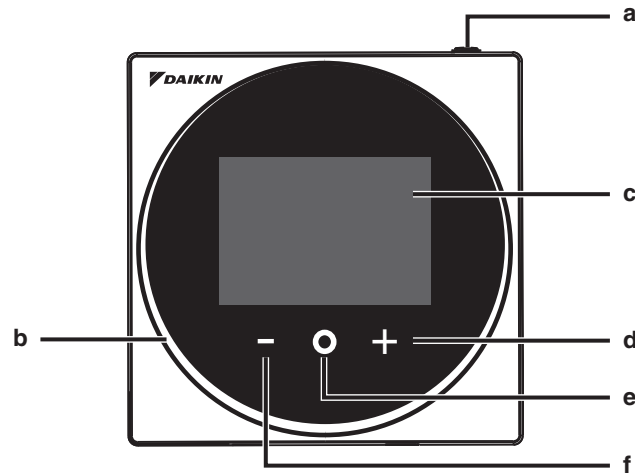

## 2.2 BRC1H71W

### 2.2.1 Button Locations and Descriptions



- a**  **ON/OFF button**
- Press this button to turn on the system.
  - Press this button again to turn off the system.
- b** **Status indicator (LED)**
- During operation, the light ring around the display lights up blue/red/green.  
Lights up blue: Operating, Blinks red: Error is occurring, Lights up/blinks green: Bluetooth connecting
- c** **LCD**
- Displays the current setpoint and air conditioner operation status.
- d**  **NAVIGATE/ADJUST button**
- Navigate right.
  - Adjust a setting.
- e**  **SELECT/ACTIVATE/SET button**
- From the home screen, enter the user menu.
  - From the user menu, enter one of the submenus.
  - From their respective submenu, activate an operation/ventilation mode.
- f**  **NAVIGATE/ADJUST button**
- Navigate left.
  - Adjust the setting.

## 2.2.2 Overview of Screens



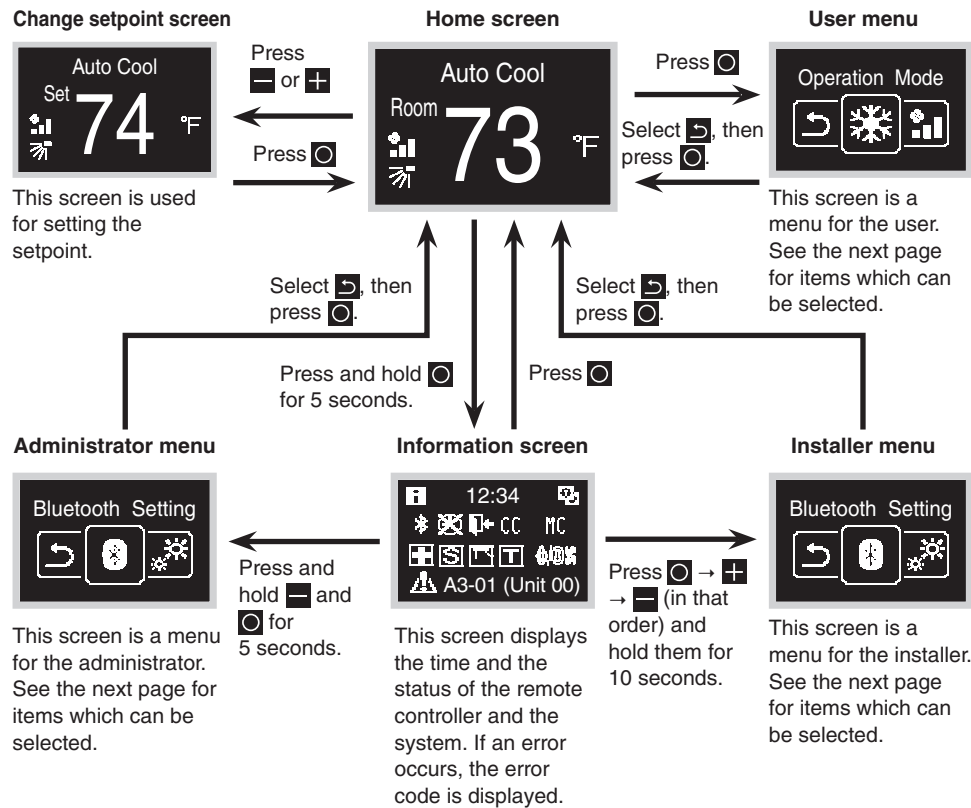

The following is just an example. The items available for setting vary depending on the indoor unit you are using. If there is no button operation for about 10 seconds, the screen returns to the home screen.

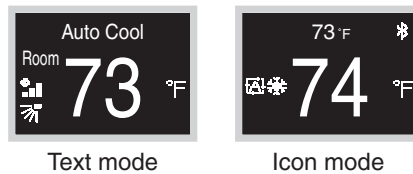













There are 2 screen display modes, text mode and icon mode.  
 Change the mode according to your preference.  
 \* All of the above explanations are shown with screens from text mode.



## 2.2.3 Setting Screen List

Setting list			User menu	Administrator menu	Installer menu
Icon	Name	Description			
Depends on current setting	Operation Mode	Operation mode setting	●		
Depends on current setting	Fan Speed	Airflow rate setting	●		
Depends on current setting	Airflow Direction	Airflow direction 1 setting	●		
Depends on current setting	Vertical Airflow	Airflow direction 2 setting	●		
Depends on current setting	Ventilation Mode	Ventilation mode setting	●		
Depends on current setting	Ventilation Rate	Ventilation rate setting	●		
	Adjust LED (ON)	LED brightness adjustment when backlight lights up	●		
	Adjust LED (OFF)	LED brightness adjustment when backlight lights up dimly	●		
	Celsius/Fahrenheit	Fahrenheit/Celsius changeover	●		
	Setpoint	Setpoint setting when in auto operation mode	●		
	Sign Reset	Filter sign reset	●		

Setting list			User menu	Administrator menu	Installer menu
Icon	Name	Description			
	Bluetooth Setting	Bluetooth setting		●	●
	Backlight	Backlight brightness setting		●	●
	Contrast	Contrast setting		●	●
	Clock Setting	Clock setting		●	●
	Standard Temp	Scale reference temperature setting		●	●
	About	Administrator information		●	●
	Admin Password	Administrator password setting		●	
	Installer Password	Installer password setting			●
	Field Setting	Field Setting			●
	R/C Setting	R/C Setting			●
	Address Setting	Address Setting			●
	Forced Fan ON	Forced Fan ON Setting			●
	Rel Master Control	Release changeover master			●

## 2.2.4 Names and Functions

### Home screen

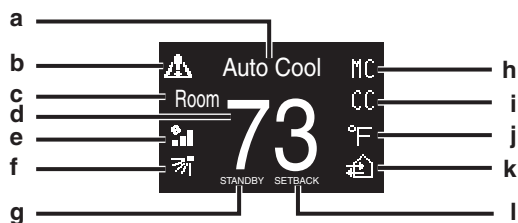

### Information screen



### User menu/Administrator menu/Installer menu

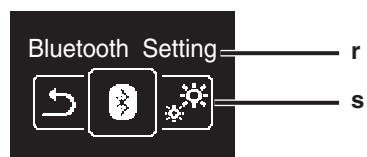
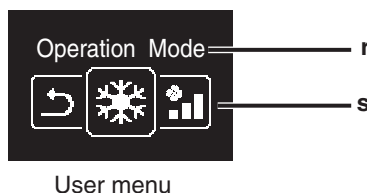

Administrator menu/Installer menu

The Bluetooth® word mark and logos are registered trademarks owned by the Bluetooth SIG, Inc. and use of such marks by Daikin industries, LTD. is under license. Other trademarks and trade names are those of their respective owners.

### **i** INFORMATION

Depending on the connected model, some items may not be displayed.

The controller is equipped with a power-saving function that darkens the display if there is no operation for a certain period of time. To make the screen light up again, press one of the buttons.

Note that pressing one of the buttons will only make the display bright again, not cause remote controller operation.

\* All screens shown are from text mode.

### Screen display explanation

- a Operation mode/OFF display**
  - Displays the operation status.
- b Error/Filter/Test icon**
  - Error, filter and test icons are displayed.
- c Room/Set**
  - Indicates whether it's a room temperature display (Room) or setpoint display (Set).
- d Room temperature/Set temperature**
  - Displays the current room or setpoint temperature.
- e Fan speed**
  - Displays the set fan speed.
- f Airflow direction**
  - Displays the set airflow direction.
- g STANDBY**
  - Displays during defrost/hot start.
- h Changeover controlled by the master indoor unit**
  - Displayed when another indoor unit on the system has the authority to change the operation mode between cool and heat.
- i Under centralized control**
  - Displayed if the system is under the management of a multi-zone controller (Optional) and the operation of the system through the remote controller is limited.
- j Fahrenheit/Celsius**
  - Depending on the setting, Fahrenheit/Celsius display can be selected.
- k Ventilation operation/Air Purify**
  - Displayed when a Heat Reclaim Ventilator is connected.
- l Setback**
  - Blinks during setback operation.
  - Displayed during setback setting.
- m Information icon**
- n Clock (24 hours time display)**
- o MAIN/SUB remote controller sign**
- p Status**
  - Notifies the status.
- q Error display**
  - If an error occurs, the icon, an error code and unit number are displayed.
- r Settings menu name**
- s Settings menu icon**

## Home screen list

There are 4 types of home screen.

The home screen type can be changed by the remote controller setting.

Text mode

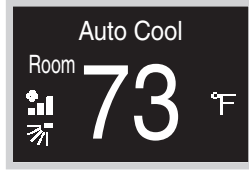

Icon mode



Text mode (Scale screen)

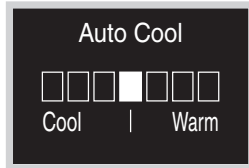

Icon mode (Scale screen)

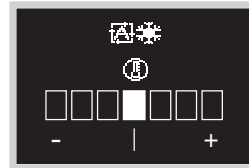

When in the scale screen, the setpoint can be changed in the range of  $\pm 3^{\circ}\text{C}/^{\circ}\text{F}$  of the reference temperature.

The reference temperature can be changed from the smartphone application or the remote controller (from the administrator menu).





## 2.2.5 Information Screen

The functions of the connected indoor unit are displayed as icons.

### How to display the information screen

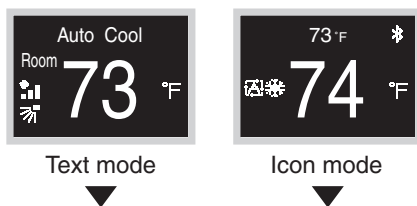
Home screen



Press and hold  on the Home screen for 5 seconds.

Information screen



The screen switches to the Information screen.

### How to exit the information screen

Information screen

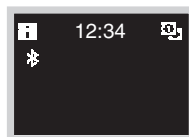

Press  or there is no button operation for about 10 seconds, the screen returns to the home screen.

## About icons on the information screen

The items displayed vary depending on the indoor unit you are using.

Icon	Name	Description
	<b>Information</b>	Indicates an information screen.
	<b>MAIN/SUB remote controller</b>	Displayed when used as the MAIN/SUB remote controller. 1=main, 2=sub
	<b>Bluetooth*</b>	Indicates that the controller is communicating with a mobile device, for use with the app.
	<b>Clock not set</b>	Indicates that the clock needs to be set again.
	<b>Setback</b>	Indicates that the indoor unit is operating under setback conditions.
	<b>Under centralized control</b>	Indicates that the system is controlled by central control equipment (optional accessory) and that control of the system by the controller is limited.
	<b>Changeover controlled by the master indoor unit</b>	<p><b>Displayed:</b> The remote controller does not have master control. Unable to select heating/cooling operation.</p> <p><b>Blinking:</b> None of the remote controllers in the system have master control. Can be set as the master controller during this time.</p> <p><b>Not Displayed:</b> The remote controller has master control. Able to select heating/cooling operation.</p>
	<b>Backup</b>	Indicates that backup operation is being carried out.
	<b>Energy savings</b>	Indicates that the system's energy consumption is being limited, and that it is running with restricted capacity.
	<b>Individual airflow direction</b>	Indicates that the individual airflow direction setting is enabled.
	<b>Test operation</b>	Indicates that Test Operation mode is active.
	<b>Stand by for Defrost/Hot start</b>	Indicates that the defrost/hot start mode is active.
	<b>Self-cleaning filter operation</b>	Indicates that self-cleaning filter operation is active.
	<b>Inspection</b>	Indicates that the indoor or outdoor unit is being inspected.
	<b>Periodic inspection</b>	Indicates that the indoor or outdoor unit is being inspected.
	<b>Ventilating operation</b>	Indicates that ventilating operation is being carried out.
	<b>Warning</b>	Indicates that an error occurred, or that an indoor unit component needs to be maintained.

\* The Bluetooth® word mark and logos are registered trademarks owned by the Bluetooth SIG, Inc. and use of such marks by Daikin industries, LTD. is under license. Other trademarks and trade names are those of their respective owners.

## 2.3 Wireless Remote Controller

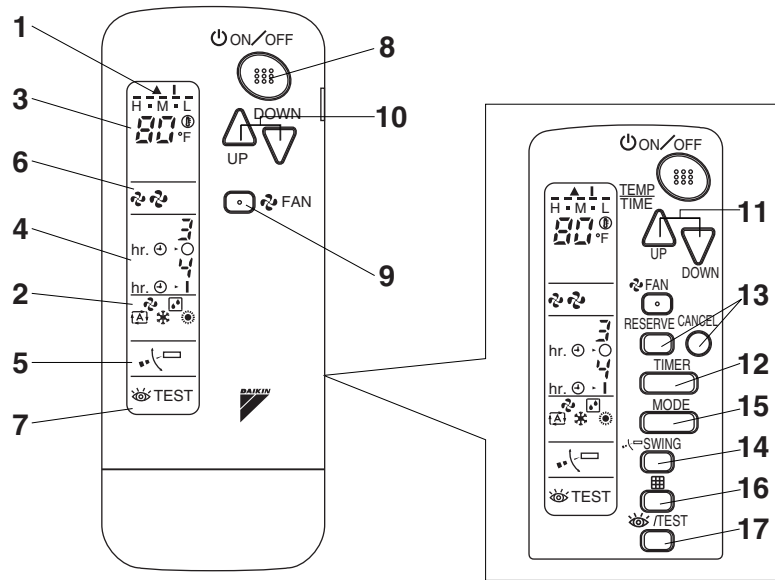

1	<b>DISPLAY ▲ (SIGNAL TRANSMISSION)</b> This lights up when a signal is being transmitted.
2	<b>DISPLAY      (OPERATION MODE)</b> This display shows the current OPERATION MODE.
3	<b>DISPLAY  80°F (SET TEMPERATURE)</b> This display shows the set temperature.
4	<b>DISPLAY hr. 0 3 hr. 0 4 (PROGRAMMED TIME)</b> This display shows programmed time of the system start or stop.
5	<b>DISPLAY  (AIRFLOW FLAP)</b>
6	<b>DISPLAY  (FAN SPEED)</b> The display shows the set fan speed.
7	<b>DISPLAY  TEST (INSPECTION/TEST)</b> When the <b>INSPECTION/TEST</b> button is pressed, the display shows the system mode is in.
8	<b>ON/OFF BUTTON</b> Press the button and the system will start. Press the button again and the system will stop.

9	<b>FAN SPEED CONTROL BUTTON</b> Press this button to select the fan speed, HIGH or LOW, of your choice.
10	<b>TEMPERATURE SETTING BUTTON</b> Use this button for setting temperature (Operates with the front cover of the remote controller closed.)
11	<b>PROGRAMMING TIMER BUTTON</b> Use this button for programming start and/or stop time. (Operates with the front cover of the remote controller opened.)
12	<b>TIMER MODE START/STOP BUTTON</b>
13	<b>TIMER RESERVE/CANCEL BUTTON</b>
14	<b>AIRFLOW DIRECTION ADJUST BUTTON</b>
15	<b>OPERATION MODE SELECTOR BUTTON</b> Press this button to select operation mode.
16	<b>FILTER SIGN RESET BUTTON</b>
17	<b>INSPECTION/TEST BUTTON</b> This button is used only by qualified service persons for maintenance purposes.

## 3. Main/Sub Setting

### 3.1 BRC1E73

#### Situation

The Main/Sub setting is necessary when 1 indoor unit is controlled by 2 remote controllers. When you use 2 remote controllers (control panel and separate remote controller), set one to Main and the other to Sub.

#### Setting

The remote controllers are factory setting to Main, so you only have to change one remote controller from Main to Sub. To change a remote controller from Main to Sub, proceed as follows:

#### 3.1.1 Field Settings

The designation of the main and sub remote controllers can be swapped. Note that this change requires turning the power OFF and then ON again.

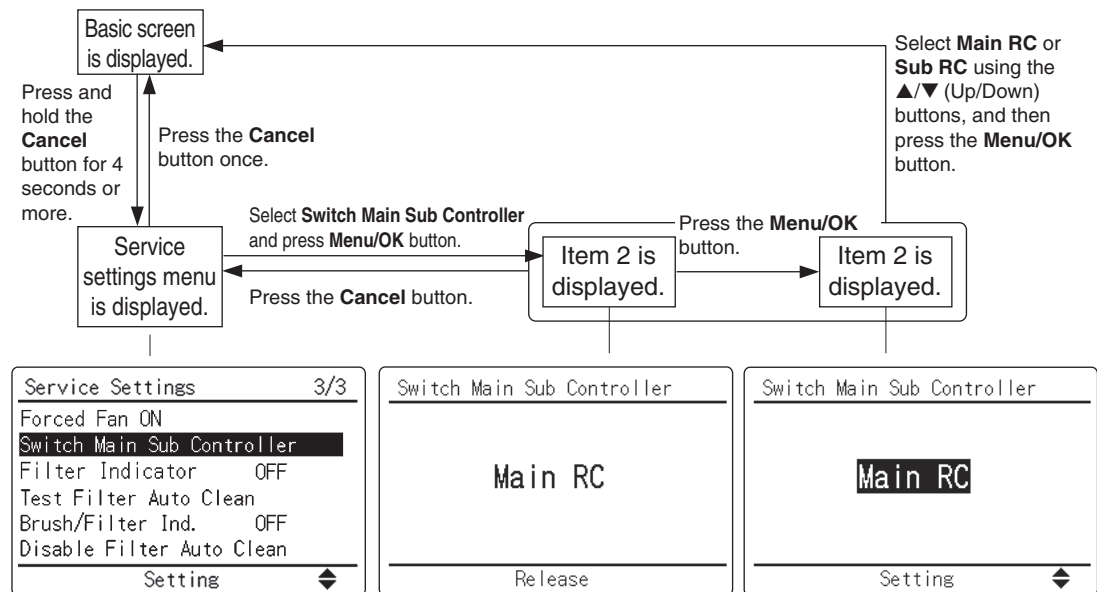

### 3.1.2 When an Error Occurred

**U5: there are 2 main remote controllers when power is turned ON**

→Change the setting from Main to Sub on the remote controller you want to be Sub.

**U8: there are 2 sub remote controllers when power is turned ON**

→Change the setting from Sub to Main on the remote controller you want to be Main.

#### How to confirm Main/Sub setting

The Main/Sub setting of the remote controller is displayed on the bottom of the screen while **Checking the connection. Please stand by.** is displayed.

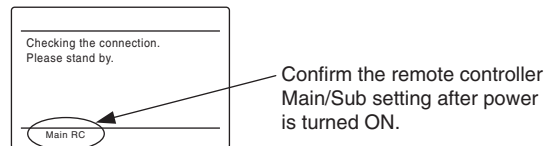

#### How to change Main/Sub setting

You may change the Main/Sub setting of the remote controller while **Checking the connection. Please stand by.** is displayed by pressing and holding the **Mode Selector** button for 4 seconds or longer.

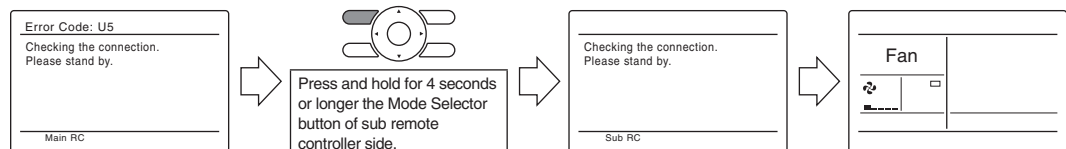

#### Note(s)

1. It is not possible to change the Main/Sub setting from Main to Sub when only one remote controller is connected.
2. When 2 remote controllers are being used, it is not possible to change the setting from Main to Sub if one of the remote controllers is already set as Main.

## 3.2 BRC1H71W

### 3.2.1 Main and Sub Controller

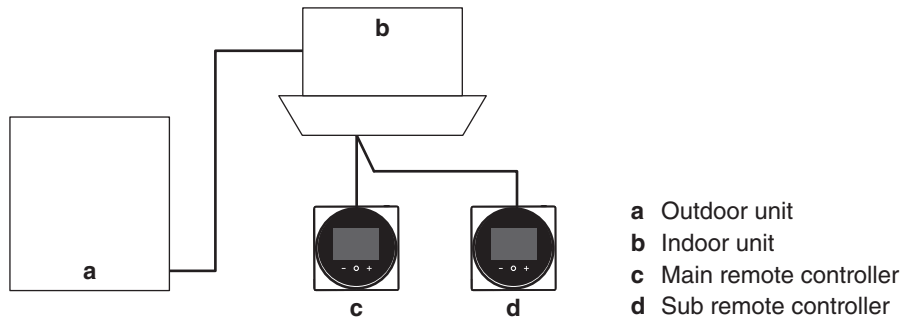

- On the information screen, main/sub status is indicated by the following icons:

Icon	Description
	Main
	Sub

#### **i** INFORMATION

It is only possible to use a main and a sub controller of the same type.

#### **i** INFORMATION

If a sub controller does not display the home screen 2 minutes after its designation, turn off the power and check the wiring.

#### **i** INFORMATION

After re-designating a controller, the system requires a power reset.

#### **i** INFORMATION

The following functions are not available for sub controllers:

- “Auto” operation mode
- Individual airflow direction
- Filter auto clean
- Setback temperature setpoints
- Draft prevention

## 3.2.2 Designating a Controller as Main or Sub

**Prerequisite:** A remote controller is already connected to the indoor unit.

Connect a second controller.

After turning on the power, perform setting of the second controller.

**Result:** It will start up automatically.



Home screen

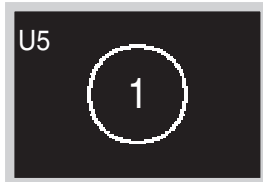

Wait for a U5 or U8 error code to appear on the screen.

Screen display explanation

1 main

2 sub



Home screen



When the U5 error code appears, press  and hold until "2" appears on the screen.

When the U8 error code appears, press  and hold until "1" appears on the screen.

**Result:**

A controller displaying 1 is set as main, and a controller displaying 2 is set as sub.



### INFORMATION

If sub remote controller is not set at power-on in the case of one indoor unit controlled by two remote controllers, Error Code: U5 is displayed in the connection checking screen.

If the sub remote controller does not display the home screen two minutes after its designation, turn off the power and check the wiring.

### 3.3 When Wireless Remote Controller is Used Together

When using both a wired and a wireless remote controller for 1 indoor unit, the wired controller should be set to Main. Therefore, the Main/Sub switch (SS1) of the signal receiver PCB must be set to Sub.

Main/Sub	Main	Sub
Main/Sub switch (SS1)		

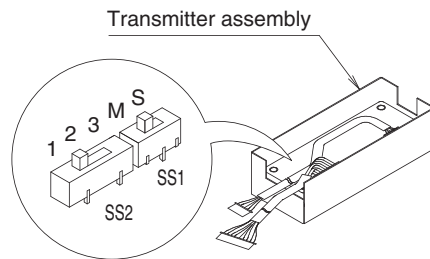
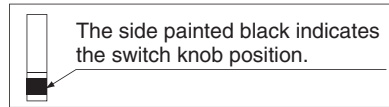



## 4. Address Setting for Wireless Remote Controller



If setting multiple wireless remote controllers to operate in one room, perform address setting for the receiver and the wireless remote controller.

(This includes an individual remote controller control using the group operation.)

(For the wiring for the group operation, please refer to the installation manual attached to the indoor unit.)

### Setting for signal receiver PCB

The address for the receiver is set to 1 at the factory. To change the setting, set the wireless address switch (SS2) on the signal receiver PCB according to the table below.

Unit No.	No. 1	No. 2	No. 3
Wireless address switch (SS2)			

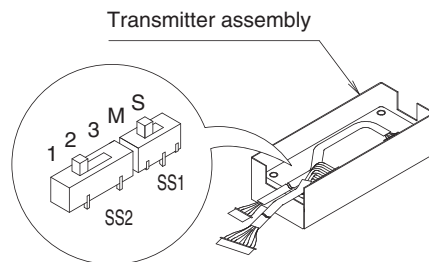
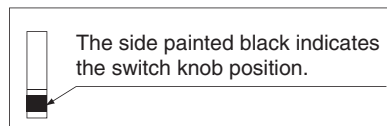

### Setting for wireless remote controller

The address for the wireless remote controller is set to 1 at the factory. To change the setting, proceed as follows:

1. Press **FILTER SIGN RESET** button and **INSPECTION/TEST** button at the same time for 4 seconds to enter field setting mode. (**SETTING** is indicated on the display.)
2. Press **FAN** button and select **A** or **b**. Each time the button is pressed, the display switches between **A** and **b**.
3. Press **UP** button or **DOWN** button to select an address from 1-3 as same as the receiver. Address can be set from 1-6, but the receiver does not work with addresses 4-6.

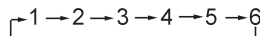

4. Press **RESERVE** button to confirm the setting.

5. Press **INSPECTION/TEST** button for 1 second to return to normal mode.

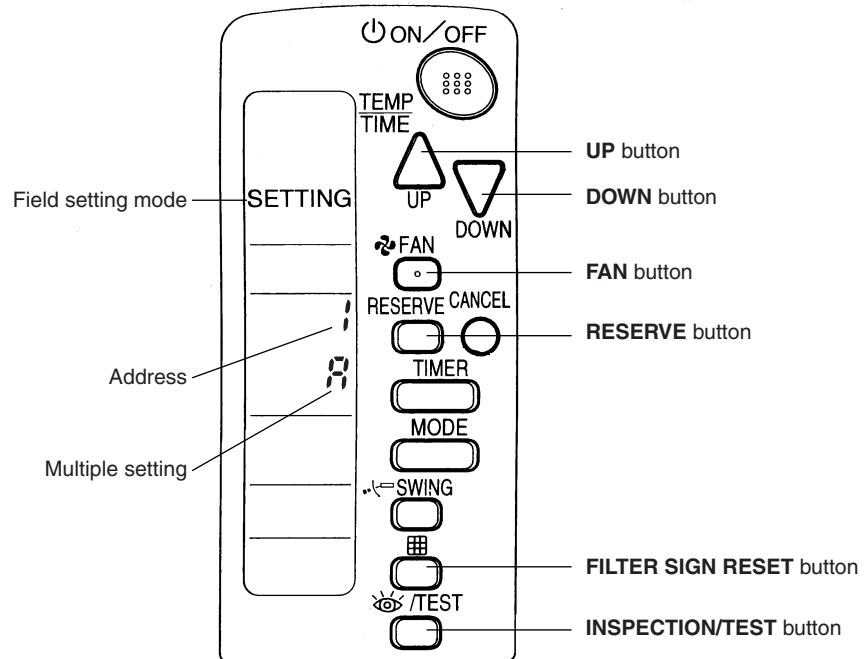

**Multiple Settings A/b**

The command such as operation mode or temperature setting by this remote controller will be rejected when the target indoor unit operation is restricted as by an external control such as centralized control.

Since the setting acceptance is hard to discriminate with such circumstances there are two setting options provided to enable discriminating by a beeping sound according to the operation: "A: Standard" or "b: Multi System". Set the setting according to the customer's intention.

Remote Controller		Indoor Unit	
Multiple setting	Display on remote controller	Behavior to the remote controller operation when the functions are restricted as by an external control.	Other than the left
<b>A: Standard</b> (factory set)	All items displayed.	Accepts the functions except restricted. (Sounds one long beep or three short beeps) There may be a difference from the indoor unit status with remote controller display.	Accepts all items transmitted (Sounds two short beeps) The remote controller display agrees with the indoor unit status.
<b>b: Multi System</b>	Display only items transmitted for a while.	<p><b>&lt;When some restricted functions are included in the transmitted items&gt;</b> Accepts the functions except restricted. (Sounds one long beep or three short beeps) There may be a difference from the indoor unit status with remote controller display.</p> <p><b>&lt;When no restricted function is included&gt;</b> Accepts all items transmitted (Sounds two short beeps) The remote controller display agrees with the indoor unit status.</p>	

# 5. Centralized Control Group No. Setting

## 5.1 BRC1E73

In order to conduct the centralized remote control using the central remote controller and the unified ON/OFF controller, Group No. settings should be made by group using the operating remote controller.

Make Group No. settings for centralized remote control using the operating remote controller.

### When initializing Group Address

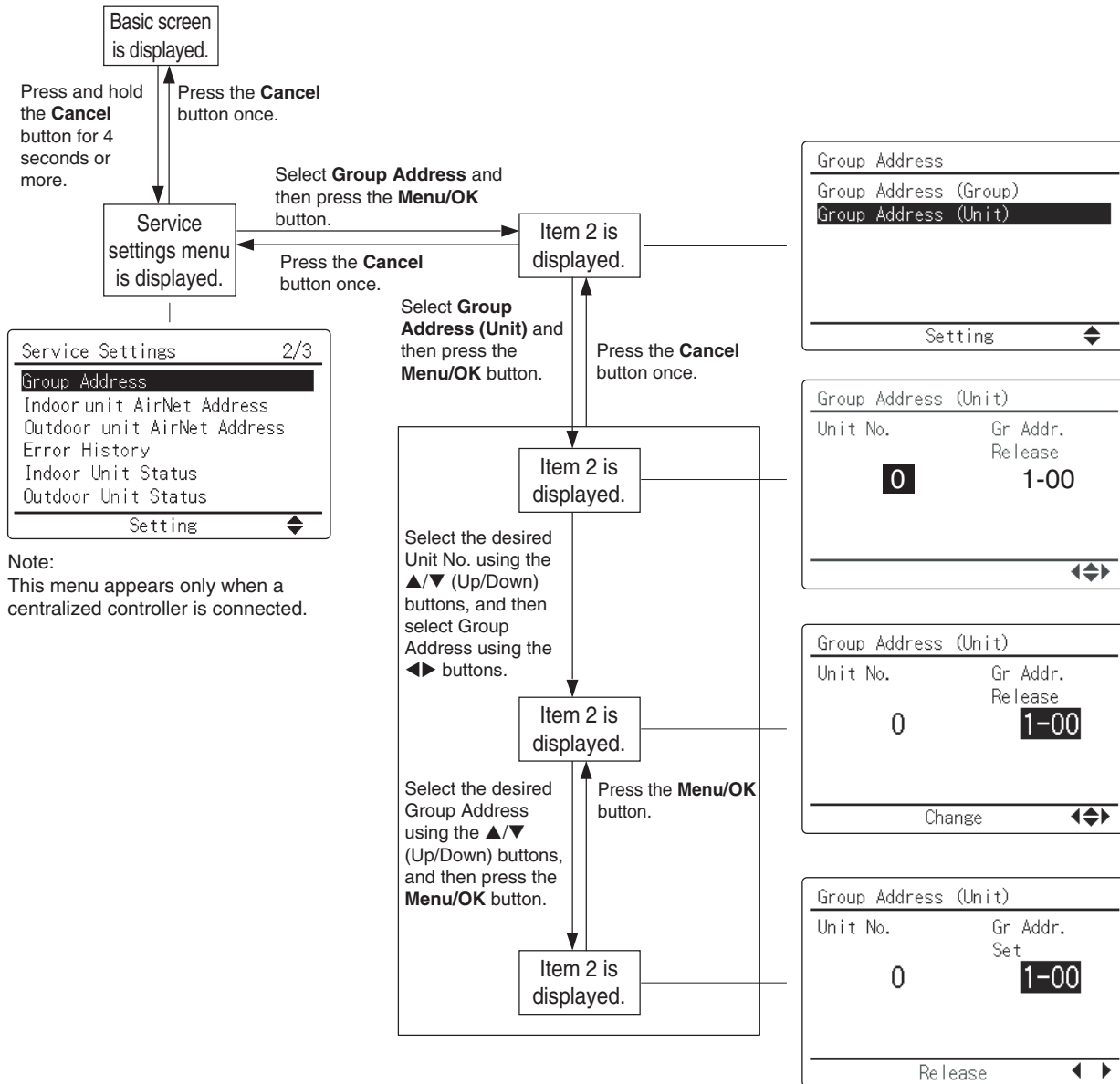

Note:  
This menu appears only when a centralized controller is connected.

Service settings menu	Item 2
Group Address	Group Address (Group)
	Group Address (Unit)

#### ■ Description

This menu is used to make group address setting for centralized control. It is also used to make group address setting by indoor unit.

- Note(s)** ■ For setting group No. of Energy recovery ventilator and wiring adaptor for other air conditioners, etc., refer to the instruction manual.

**NOTICE**

Enter the group No. and installation place of the indoor unit into the installation table. Be sure to keep the installation table with the operation manual for maintenance.

**Group Address (Group)**

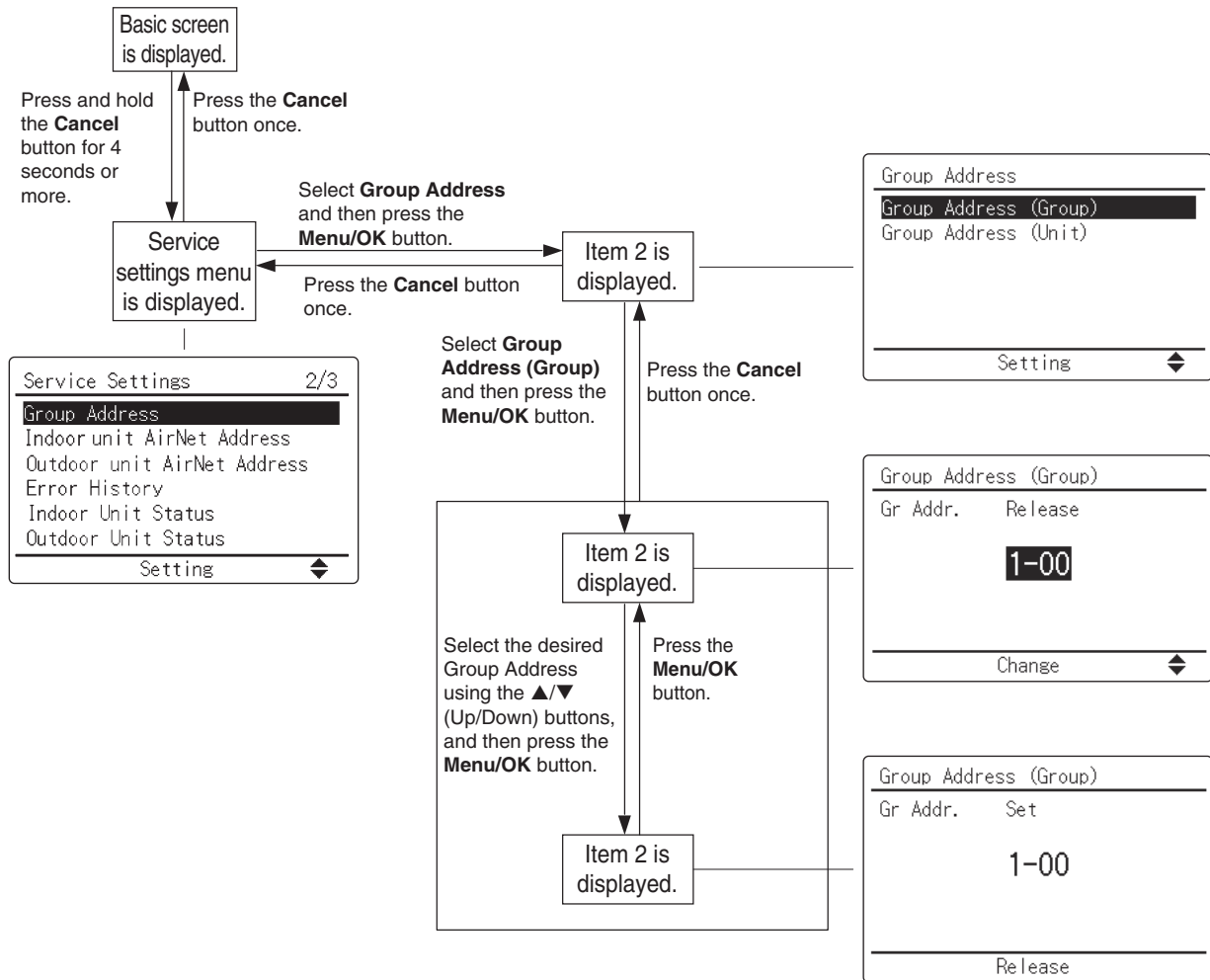

## 5.2 BRC1H71W

### Group Address

- Assign the group address and unit number for centralized control.
- The group and unit address can only be set when a centralized controller is connected.  
This menu is only visible when a centralized controller is connected.
- The group and unit address can be “set” and “released”.

### NOTICE

Don't forget to release the group address before disconnecting the centralized controller because the menu will not be accessible afterwards.

#### Manual setting mode

- Installer setting
- RC settings
- Maintenance

#### Group address setting Main

Set the indoor unit group address.  
After all settings are complete, press the “Send to RC” button.

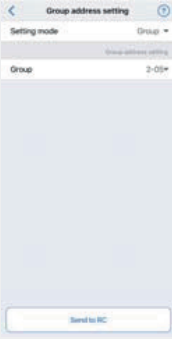

#### Manual setting mode

- Installer setting
- RC settings
- Maintenance

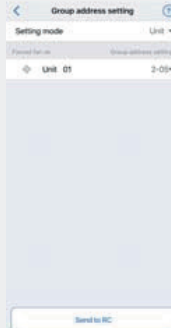

▶ **Setting mode**  
You can switch between setting the indoor unit group address for each group, or for each unit.

#### Manual setting mode

- Installer setting
- RC settings
- Maintenance

▶ **Group**  
Set the group address on a per-group basis.  
\* Set a group address only for the MAIN unit.

▶ **Unit**  
Set the group address on a per-unit basis.

▶ **Forced fan on**  
Force operation of the fan of the unit number whose icon has been tapped.  
You can confirm the location of the device on which you are performing settings.

## 5.3 Wireless Remote Controller

Group No. setting by wireless remote controller for centralized control

1. When in the normal mode, press **INSPECTION/TEST** button for 4 seconds or more to enter field setting mode.
2. Set mode No. 00 with **MODE** button.
3. Set the group No. for each group with **UP** button or **DOWN** button.
4. Enter the selected group numbers by pressing **RESERVE** button.

5. Press **INSPECTION/TEST** button and return to the normal mode.

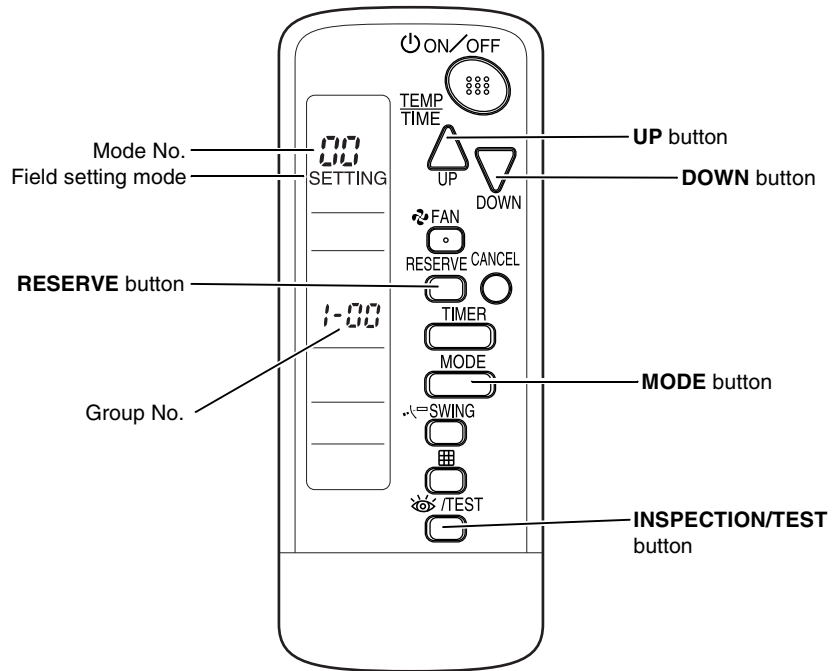

## 5.4 Group No. Setting Example

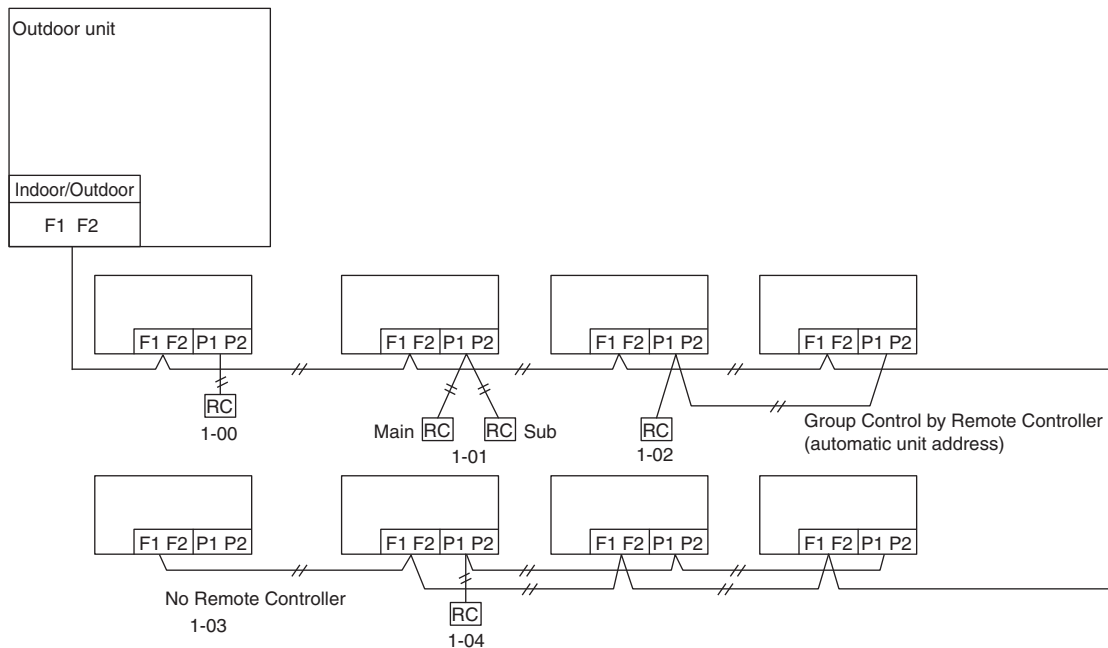

**Caution**

When turning the power supply on, the unit may often not accept any operation after all indications were displayed once for about 1 minute on the liquid crystal display. This is not an operative fault.

# 6. Service Settings Menu, Maintenance Menu

## 6.1 BRC1E73

Operating the remote controller allows service data to be acquired and various services to be set.

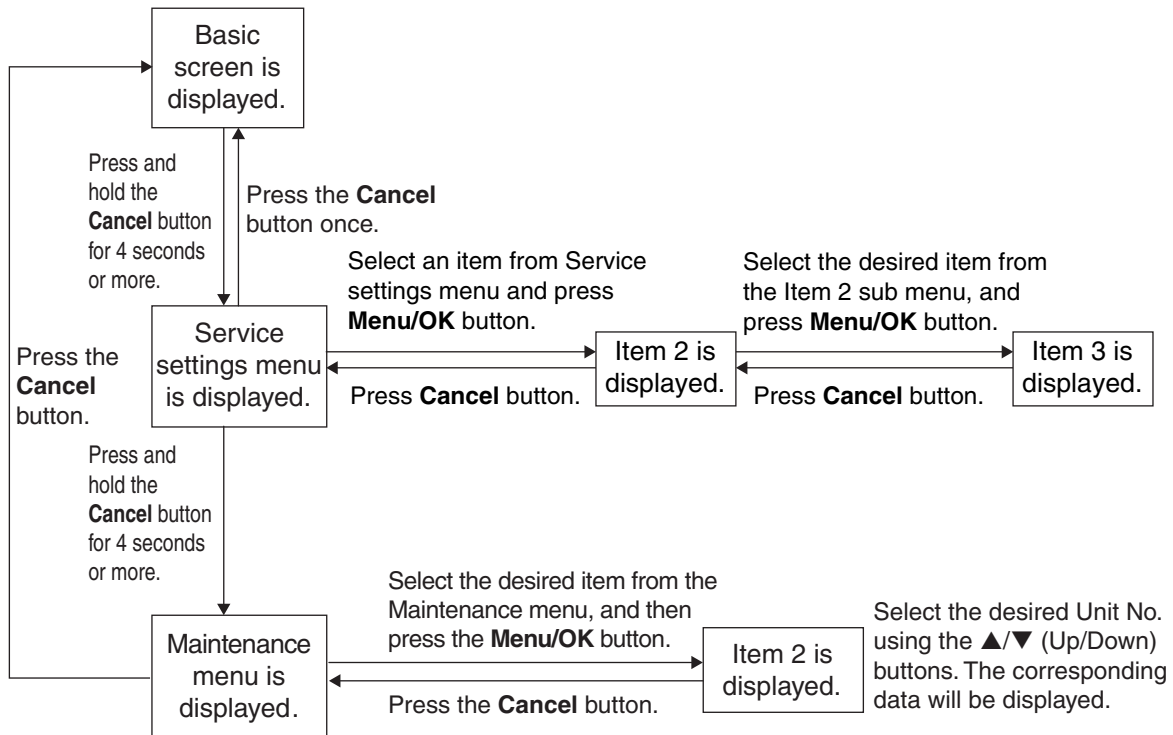

## 6.1.1 Service Settings Menu

Service settings menu	Item 2	Remarks
Test Operation	—	—
Maintenance Contact	None	—
	Maintenance Contact	—, 0 to 9 (in order)
Field Settings	Indoor Unit No.	—
	Mode No.	—
	First Code No.	—
	Second Code No.	—
Energy Saving Options	Setpoint Range Limitation	Temperature
	Setback Configuration	Recovery Differential
	Auto-setback by Sensor	Enable/Disable, Settings
	Auto-off by Sensor	Enable/Disable, Auto-off in (hours)
Prohibit Function	Prohibit Buttons	Up/Down, Left, Right, On/Off, Mode, Fan Speed
	Prohibit Mode	Fan, Cool, Heat, Auto, Dry, Vent Clean
Min setpoints Differential	None, Single SP, 0 to 8°F	—
Group Address	Group Address (Group)	Gr Addr. Set
	Group Address (Unit)	Unit No., Gr Addr. Set
Indoor unit Airnet Address	Unit No., Address Set	—
Outdoor unit Airnet Address	Unit No., Address Set	—
Error History	RC Error History	Unit No., Error, Date, Time (Up to 10 errors received by the remote controller can be displayed.)
	Indoor Unit Error History	Unit No., Error, Date, Time (Up to 5 errors from the indoor unit error record can be displayed.)
Indoor Unit Status	Unit No.	—
	Th1	Suction air thermistor
	Th2	Heat exchanger liquid pipe thermistor
	Th3	Heat exchanger gas pipe thermistor
	Th4	Discharge air thermistor
	Th5	Remote controller thermistor (FXSQ-TA, FXSQ-TB, FXMQ-TB, FXTQ-TA, CXTQ-TA) Floor temperature thermistor (FXFQ-T, FXZQ-TA, FXZQ-TB, FXUQ-P, FXUQ-PA, FXEQ-P)
	Th6	Control temperature (FXFQ-T, FXZQ-TA, FXZQ-TB, FXUQ-P, FXUQ-PA, FXEQ-P, FXSQ-TA, FXSQ-TB, FXMQ-TB, FXTQ-TA, CXTQ-TA)
Outdoor Unit Status	Unit No.	—
	Th1	—
	Th2	—
	Th3	—
	Th4	—
	Th5	—
	Th6	—
Forced Fan ON	Unit No.	—
Switch Main Sub controller	—	—
Filter Indicator	—	—
Test Filter Auto Clean	—	—
Brush / Filter Ind	—	—
Disable Filter Auto Clean	No, Yes	—



## 6.1.2 Maintenance Menu

Maintenance Menu	Item 2	Remarks
Model Name	Unit No.	Select the unit number you want to check.
	Indoor unit	The model names are displayed. (A model code may be displayed instead, depending on the particular model.)
	Outdoor unit	
Operation Hours	Unit No.	Select the unit number you want to check.
	Indoor unit operation hours	All of these are displayed in hours.
	Indoor fan operation hours	
	Indoor unit energized hours	
	Outdoor unit operation hours	
	Outdoor fan 1 operation hours	
	Outdoor fan 2 operation hours	
	Outdoor compressor 1 operation hours	
	Outdoor compressor 2 operation hours	
Indoor Unit Status	Unit No.	
	FAN	Fan tap (*1)
	Speed	Fan speed (rpm) (*2)
	FLAP	Swing, fixed
	EV	Degree that electronic expansion valve is open (pulse)
	MP	Drain pump ON/OFF
	EH	Electric heater ON/OFF
	Hu	Humidifier ON/OFF (*3)
	TBF	Anti-freezing control ON/OFF
	FLOAT	Float switch OPEN/CLOSE
	T1/T2	T1/T2 external input OPEN/CLOSE
	Th1	Suction air thermistor
	Th2	Heat exchanger liquid pipe thermistor
	Th3	Heat exchanger gas pipe thermistor
	Th4	Discharge air thermistor
	Th5	Remote controller thermistor (FXFQ-T, FXSQ-TA, FXSQ-TB, FXMQ-PB, FXMQ-TB, FXTQ-TA, CXTQ-TA) Floor temperature thermistor (FXFQ-T, FXZQ-TA, FXZQ-TB, FXUQ-P, FXUQ-PA, FXEQ-P)
Th6	Control temperature (FXFQ-T, FXZQ-TA, FXZQ-TB, FXUQ-P, FXUQ-PA, FXEQ-P, FXSQ-TA, FXSQ-TB, FXMQ-PB, FXMQ-TB, FXTQ-TA, CXTQ-TA)	
Outdoor Unit Status	Unit No.	Select the Unit No. you want to check.
	FAN step	Fan tap
	COMP	Compressor power supply frequency (Hz)
	EV1	Degree that electronic expansion valve is open (pulse)
	SV1	Solenoid valve ON/OFF
	Th1	—
	Th2	—
	Th3	—
	Th4	—
	Th5	—
	Th6	—

Maintenance Menu	Item 2	Remarks
Forced Defrost	Forced defrost ON	Enables the forced defrost operation.
	Forced defrost OFF	Disables the forced defrost operation.
Error Display	Display error ON	Displays the error on the screen.
	Display error OFF	Displays neither errors nor warnings.
	Display warning ON	Displays a warning on the screen if an error occurs.
	Display warning OFF	No warning is displayed.
Swap Unit No.	Current Unit No.	A unit No. can be transferred to another.
	Transfer Unit No.	
Addressed Sensor Value	Unit No.: 0 - 15	Select the unit number you want to check.
	Code	
	00:	Remote controller thermistor (°C)
	01:	Suction air thermistor (°C)
	02:	Heat exchanger liquid pipe thermistor (°C)
	03:	Heat exchanger gas pipe thermistor (°C)
	04:	Indoor unit address No.
	05:	Outdoor unit address No.
	06:	Branch Selector unit address No.
	07:	Zone control address No.
08:	Cooling/Heating batch address No.	
09:	Demand/low-noise address No.	
30: (*4)(*7)	Displays thermostat step 1 ON/OFF. Thermostat step 1 OFF: 00 Thermostat step 1 ON: 01	
31: (*4) (*5)	Displays the heat demand that CXTQ-TA is currently sending to the gas furnace (%).	
32: (*4) (*5)	Displays the fan demand that CXTQ-TA is currently sending to the gas furnace (%).	
33: (*4)	Current status of heat pump ON/OFF for CXTQ-TA HP OFF: 00 HP ON: 01	
34: (*4) (*5)	Current status of gas combustion heating Displays current heat actual status (%).	
35: (*4) (*6)	Current airflow of the fan Displays current airflow (CFM).	
Data	The corresponding data will be displayed, based on the unit number and Code selected.	

- \*1 (For FXTQ-TA, CXTQ-TA models)  
The actual fan speed is converted into the fan tap to be displayed. Therefore, if the fan speed is changed by controls or external factors, the airflow rate set with the remote controller may differ from the fan tap display.
- \*2 (For FXTQ-TA models)  
**0 rpm** is displayed even if the fan is rotating.  
(For CXTQ-TA models)  
**- rpm** is displayed even if the fan is rotating.
- \*3 (For FXTQ-TA, CXTQ-TA models)  
The ON/OFF status of the humidifier connected to HUMIDIFIER on the X1M terminal of the indoor unit PCB is not displayed. The ON/OFF status of the humidifier connected to the wiring adaptor is displayed.
- \*4 Only for CXTQ-TA
- \*5 Displays **99** when it is more than 100%.
- \*6 Display unit is by 100 CFM.  
(ex. Displays **19** for 1850 CFM. Displays **18** for 1849 CFM.)
- \*7 Refer to **2-Step Thermostat Processing (CXTQ-TA Models)** on page 122 for details.

## **7. Administrator Menu, Installer Menu**

### **7.1 BRC1H71W**

Refer to page 54 for details.

# Part 4

## Functions and Control

1. Operation Mode .....	79
2. Basic Control .....	80
2.1 Normal Operation .....	80
2.2 Compressor PI Control .....	81
2.3 Electronic Expansion Valve PI Control .....	83
2.4 Cooling Operation Fan Control .....	83
3. Special Control .....	84
3.1 Startup Control .....	84
3.2 Oil Return Control .....	86
3.3 Defrost Control .....	88
3.4 Pump Down Residual Control .....	89
3.5 Restart Standby .....	90
3.6 Stop Control .....	90
4. Protection Control .....	91
4.1 High Pressure Protection Control .....	91
4.2 Low Pressure Protection Control .....	92
4.3 Discharge Pipe Temperature Protection Control .....	93
4.4 Inverter Protection Control .....	94
5. Other Control .....	96
5.1 Demand Operation .....	96
5.2 Heating Operation Prohibition .....	96
5.3 Gas Furnace Operation Prohibition .....	96
5.4 Gas Furnace Operation Startup Prohibition .....	96
6. Outline of Control (Indoor Unit) .....	97
6.1 Operation Flowchart .....	97
6.2 Set Temperature and Control Target Temperature .....	101
6.3 Remote Controller Thermistor .....	103
6.4 Thermostat Control .....	105
6.5 Drain Pump Control .....	108
6.6 Control of Electronic Expansion Valve .....	110
6.7 Freeze-Up Prevention .....	111
6.8 List of Swing Flap Operations .....	113
6.9 Hot Start Control (In Heating Operation Only) .....	114
6.10 Louver Control for Preventing Ceiling Dirt .....	115
6.11 Heater Control (Except FXTQ-TA Models) .....	116
6.12 Heater Control (FXTQ-TA Models) .....	117
6.13 Gas Furnace Control (CXTQ-TA Models) .....	120
6.14 3-Step Thermostat Processing (FXTQ-TA Models) .....	121
6.15 2-Step Thermostat Processing (CXTQ-TA Models) .....	122

6.16 Fan Control (Heater Residual) (FXTQ-TA Models).....	123
6.17 Interlocked with External Equipment (FXTQ-TA and CXTQ-TA Models)...	123

# 1. Operation Mode

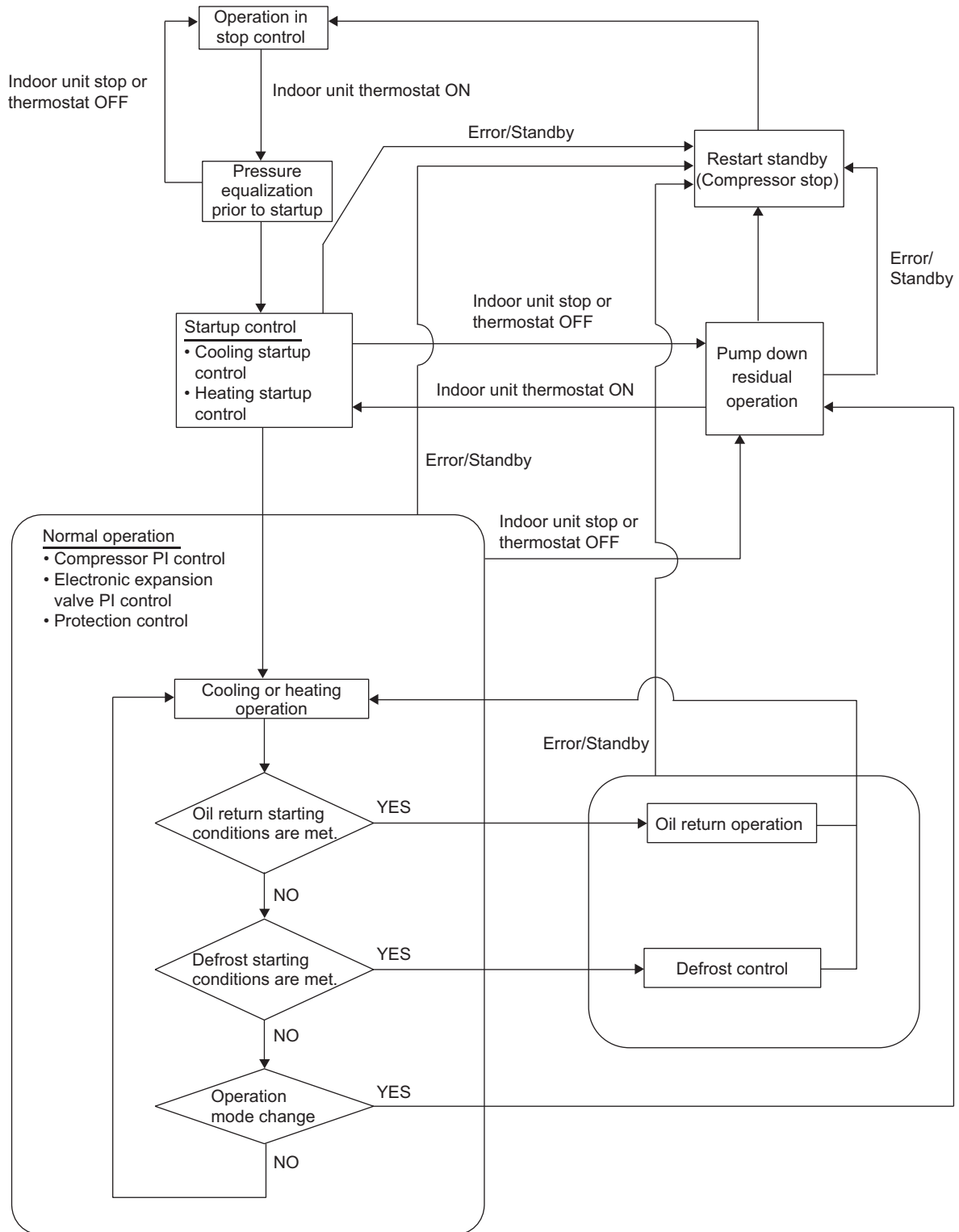

**i Note(s)** In the event that the indoor unit stops or the thermostat turns OFF while in oil return operation or defrost control, pump down residual operation is performed on completion of the oil return operation or defrost control.

## 2. Basic Control

### 2.1 Normal Operation

#### Cooling Operation

Outdoor unit actuator	Electric symbol			Operation	Remarks
	24/36 class	48 class	60 class		
Compressor	M1C	M1C	M1C	Compressor PI control	Used for high pressure protection control, low pressure protection control, discharge pipe temperature protection control, and compressor operating frequency upper limit control with inverter protection control.
Outdoor fan	M1F	M1F	M1F M2F	Cooling fan control	—
Electronic expansion valve (Main)	Y1E	Y1E	Y1E	480 pulse (Fully open)	—
Electronic expansion valve (Subcooling)	—	—	Y3E	PI control	—
Four way valve	Y1S	Y1S	Y1S	OFF	—
Hot gas bypass valve	Y2S	—	—	OFF	This valve turns ON with low pressure protection control.
Injection valve	Y3S	Y3S	—	OFF	This valve turns ON with high discharge temperature protection control.

#### Heating Operation

Outdoor unit actuator	Electric symbol			Operation	Remarks
	24/36 class	48 class	60 class		
Compressor	M1C	M1C	M1C	Compressor PI control	Used for high pressure protection control, low pressure protection control, discharge pipe temperature protection control, and compressor operating frequency upper limit control with inverter protection control.
Outdoor fan	M1F	M1F	M1F M2F	STEP 7 or 8	—
Electronic expansion valve (Main)	Y1E	Y1E	Y1E	PI control	—
Electronic expansion valve (Subcooling)	—	—	Y3E	PI control	—
Four way valve	Y1S	Y1S	Y1S	ON	—
Hot gas bypass valve	Y2S	—	—	OFF	This valve turns ON with low pressure protection control.
Injection valve	Y3S	Y3S	—	OFF	This valve turns ON with high discharge temperature protection control.

\* Heating operation is not functional at an outdoor air temperature of 24°CDB (75.2°FDB) or more.

## 2.2 Compressor PI Control

Carries out compressor capacity PI control to maintain Te at constant during cooling operation and Tc at constant during heating operation, thus ensuring stable unit performance.

Te: Low pressure equivalent saturation temperature

TeS: Target Te value (varies depending on Te setting, operating frequency, etc.)

Tc: High pressure equivalent saturation temperature

TcS: Target Tc value (varies depending on Tc setting, operating frequency, etc.)

### Cooling Operation

Controls compressor capacity to achieve target Te value (TeS).

#### (1) VRT control (Default)

When the required capacity of all indoor units (suction air temperature – set temperature) is small, the target evaporation temperature is further increased in order to adjust capacity. From the outdoor unit side, the temperature difference for all indoor units ( $\Delta T$ ) is confirmed, and the target temperature is changed.

#### (2) Constant pressure control

The target evaporation temperature is not changed.

Te setting (Make this setting while in setting mode 2-8.)

Lower	Normal	VRT (Default)	Higher			
3°C (37.4°F)	6°C (42.8°F)	Variable	8°C (46.4°F)	9°C (48.2°F)	10°C (50°F)	11°C (51.8°F)

#### TeS upper limit setting (setting mode 2-11) (for RXSQ48/60TB models only)

When the required capacity of all indoor units is small, setting the upper limit of the target temperature to H enables more energy-saving operation.

Note: In high-humidity areas, it is recommended to keep this setting to M or L.

Setting item	Condition		
TeS upper limit setting	L	M (Default)	H

### Heating Operation

Controls compressor capacity to achieve target Tc value (TcS).

#### (1) VRT control (Default)

When the required capacity of all indoor units (set temperature – suction air temperature) is small, the target condensation temperature is further decreased in order to adjust capacity. From the outdoor unit side, the temperature difference for all indoor units ( $\Delta T$ ) is confirmed, and the target temperature is changed.

#### (2) Constant pressure control

The target condensation temperature is not changed.

Tc setting (Make this setting while in setting mode 2-9.)

VRT (Default)	Normal	Higher
Variable	46°C (114.8°F)	52°C (125.6°F)

#### TcS lower limit setting (setting mode 2-54) (for RXSQ48/60TB models only)

When the required capacity of all indoor units is small, setting the lower limit of the target temperature to L or LL enables more energy-saving operation.

Note: The supply air temperature will become lower than the initial setting. If cold drafts are felt, return the setting to M.

Setting item	Condition			
TcS lower limit setting	LL	L	M (Default)	H



## Compressor Frequency

Step	Frequency (rps)							
	24 class		36 class		48 class		60 class	
	Cooling	Heating	Cooling	Heating	Cooling	Heating	Cooling	Heating
1	16	16	16	16	15	15	15	15
2	17.5	17.5	17.5	17.5	17.5	17.5	17.5	17.5
3	19	19	19	19	19	19	19	19
4	20.5	20.5	20.5	20.5	20.5	20.5	20.5	20.5
5	22	22	22	22	22	22	22	22
6	24.5	24	24	24	24	24	24	24
7	27	26	26	26	26	26	26	26
8	28	28.5	28.5	28.5	28.5	28.5	28.5	28.5
9	30	30	31	31	32	31	31	31
10	33	33.5	33.5	34.5	33.5	33.5	33.5	33.5
11	36.5	36.5	37	38	35	36	36.5	37.5
12	40	39.5	39.5	39.5	37	37	38.5	40.5
13	42.5	42.5	42.5	42.5	40.5	40.5	41.5	42.5
14	44.5	45.5	45.5	45.5	44.5	45.5	45.5	45.5
15	47	48.5	48.5	48.5	48.5	48.5	48.5	48.5
16	51	51	51.5	51.5	51.5	51.5	51.5	51.5
17	54.5	54.5	54.5	54.5	54.5	54.5	54.5	54.5
18	58	58	58	58	58	58	58	58
19	61	61	60.5	61	61	61	61	61
20	64	64	64	64	65.5	64	64	64
21	67	67	67	67	67.5	67.5	67.5	67.5
22	70.5	70.5	70.5	70.5	72	71	71	71
23	74	74	72	74	75	77.5	75	75
24	77.5	77.5	76	76	79	79	79	81.5
25	81	81	81	77.5	83.5	81.5	84.5	84.5
26	84.5	84.5	84.5	81	88	85	85	88
27	88.5	88.5	88.5	88.5	93	93	91.5	93
28	92.5	92.5	92.5	92.5	98	98	98	98
29	96.5	96.5	96.5	96.5	103	103	103	103
30	100.5	100.5	100.5	100.5	109	109	109	109

\* Depending on the operating conditions of the compressor, the compressor can be run in an operating mode different from the modes listed in the table above.

## 2.3 Electronic Expansion Valve PI Control

### Main Electronic Expansion Valve Control

Carries out main electronic expansion valve (Y1E) PI control to maintain the evaporator outlet superheating degree (SH) at constant during heating operation, thus making maximum use of the outdoor heat exchanger (evaporator).

SH = Ts1 – Te    SH: Evaporator outlet superheating degree  
 Ts1: Suction pipe temperature detected by thermistor R3T  
 Te: Low pressure equivalent saturation temperature

The optimum initial value of the evaporator outlet superheating degree is 3°C (5.4°F), but varies depending on the discharge pipe superheating degree of inverter compressor.

### Subcooling Electronic Expansion Valve Control

Carries out PI control of subcooling electronic expansion valve (Y3E) to keep the superheating degree (SH) of the outlet gas pipe on the evaporator side for the full use of the subcooling heat exchanger.

SH = Tsh – Te    SH: Evaporator outlet superheating degree  
 Tsh: Subcooling heat exchanger gas pipe temperature detected by thermistor R6T  
 Te: Low pressure equivalent saturation temperature

## 2.4 Cooling Operation Fan Control

In cooling operation with low outdoor air temperature, this control is used to provide an adequate amount of circulation air with liquid pressure secured by high pressure control from the outdoor fan. Furthermore, when outdoor temperature ≥ 20°C (68°F), the compressor will run in Step 7 or higher. When outdoor temperature ≥ 18°C (64.4°F), it will run in Step 5 or higher. When outdoor temperature ≥ 12°C (53.6°F), it will run in Step 1 or higher.

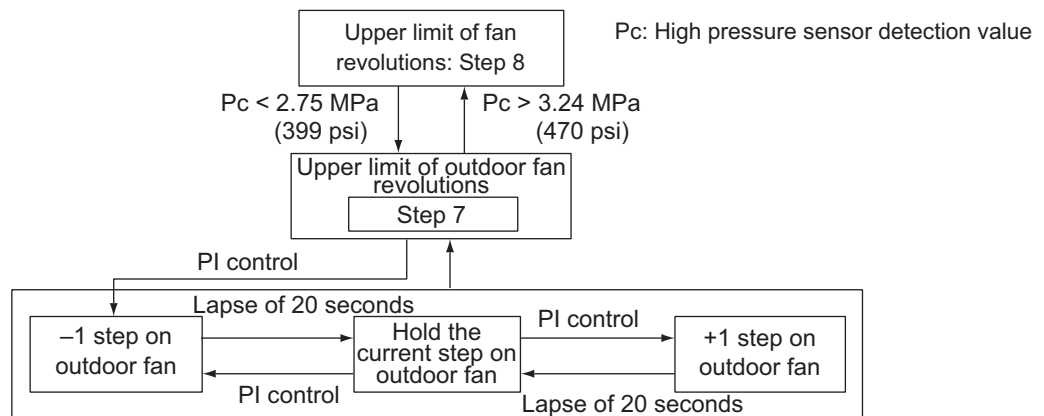

### Fan Steps

Step	Fan speed (rpm)			
	24/36 class	48 class	60 class	
			M1F	M2F
1	200	200	250	0
2	250	250	400	0
3	300	300	285	250
4	480	360	360	325
5	515	430	445	410
6	620	515	580	545
7	830	620	715	680
8	920	920	850	815

## 3. Special Control

### 3.1 Startup Control

This control is used to equalize the pressure in the front and back of the compressor prior to the startup of the compressor, thus reducing startup loads. Furthermore, the inverter is turned ON to charge the capacitor.

To avoid stresses to the compressor due to oil return or else after the startup, the following control is made and the position of the four way valve is also determined.

Pc: High pressure sensor detection value

Pe: Low pressure sensor detection value

Ta: Outdoor air temperature

Tc: High pressure equivalent saturation temperature

#### 3.1.1 Startup Control in Cooling

Outdoor unit actuator	Electric symbol			Pressure equalization control prior to startup	Startup control	
	24/36 class	48 class	60 class		STEP 1	STEP 2
Compressor	M1C	M1C	M1C	0 Hz	Minimum frequency	Increases 2 steps every 20 seconds from minimum frequency until $P_c - P_e > 0.39$ MPa (56.6 psi) is achieved
Outdoor fan	M1F	M1F	M1F M2F	OFF	Ta < 20°C (68°F): OFF Ta ≥ 20°C (68°F): STEP 4	+1 step/15 sec. (when $P_c > 2.16$ MPa (313 psi)) -1 step/15 sec. (when $P_c < 1.77$ MPa (257 psi))
Electronic expansion valve (Main)	Y1E	Y1E	Y1E	0 pulse	480 pulse (Fully open)	480 pulse (Fully open)
Electronic expansion valve (Subcooling)	—	—	Y3E	0 pulse	0 pulse	0 pulse
Four way valve	Y1S	Y1S	Y1S	Holds	OFF	OFF
Hot gas bypass valve	Y2S	—	—	ON	OFF	OFF
Injection valve	Y3S	Y3S	—	OFF	OFF	OFF
Ending conditions				OR ( <ul style="list-style-type: none"> <li>• <math>P_c - P_e &lt; 0.3</math> MPa (43.5 psi)</li> <li>• A lapse of 5 min.</li> </ul>	A lapse of 10 sec.	OR ( <ul style="list-style-type: none"> <li>• A lapse of 360 sec.</li> <li>• <math>P_c - P_e &gt; 0.39</math> MPa (56.6 psi)</li> <li>• Tc &gt; 48°C (118°F)</li> <li>• Pe &lt; 0.55 MPa (80 psi)</li> </ul>

### 3.1.2 Startup Control in Heating

Outdoor unit actuator	Electric Symbol			Pressure equalization control prior to startup	Startup control	
	24/36 class	48 class	60 class		STEP 1	STEP 2
Compressor	M1C	M1C	M1C	0 Hz	Minimum frequency	Increases 2 steps every 20 seconds from minimum frequency until $P_c - P_e > 0.39 \text{ MPa}$ (56.6 psi) is achieved
Outdoor fan	M1F	M1F	M1F M2F	From starting $T_a > 20^\circ\text{C}$ (68°F): STEP 1 $T_a \leq 20^\circ\text{C}$ (68°F): OFF	STEP 8	STEP 8
Electronic expansion valve (Main)	Y1E	Y1E	Y1E	0 pulse	0 pulse	0 pulse
Electronic expansion valve (Subcooling)	—	—	Y3E	0 pulse	0 pulse	0 pulse
Four way valve	Y1S	Y1S	Y1S	Holds	ON	ON
Hot gas bypass valve	Y2S	—	—	ON	OFF	OFF
Injection valve	Y3S	Y3S	—	OFF	OFF	OFF
Ending conditions				OR ( <ul style="list-style-type: none"> <li>• <math>P_c - P_e &lt; 0.3 \text{ MPa}</math> (43.5 psi)</li> <li>• A lapse of 5 min.</li> </ul>	A lapse of 10 sec.	OR ( <ul style="list-style-type: none"> <li>• A lapse of 130 sec.</li> <li>• <math>P_c &gt; 2.70 \text{ MPa}</math> (392 psi)</li> <li>• <math>P_c - P_e &gt; 0.39 \text{ MPa}</math> (56.6 psi)</li> </ul>

## 3.2 Oil Return Control

In order to prevent the compressor from running out of oil, oil return control is conducted to recover oil that has flowed out from the compressor to the system side.

HTdi: Compressor discharge pipe temperature (Tdi) compensated with outdoor air temperature

Pc: High pressure sensor detection value

Pe: Low pressure sensor detection value

Tc: High pressure equivalent saturation temperature

Te: Low pressure equivalent saturation temperature

Ts1: Suction pipe temperature detected by thermistor R3T

### 3.2.1 Oil Return Control in Cooling

#### Starting Conditions

- Oil return operation is not conducted before 2 hours have elapsed from the activation of power supply.
- After 2 hours have elapsed, oil return operation starts when the following item meets the reference value.
  - ◆ Total amount of oil discharged from the compressor (The total amount of oil discharged from the compressor is computed from Tc, Te, and compressor loads.)
- Oil return operation starts every 8 hours of cumulative operation of the compressor, even if the reference value is not met.

Outdoor unit actuator	Electric symbol			Oil return preparation control	Oil return control	Control after oil return
	24/36 class	48 class	60 class			
Compressor	M1C	M1C	M1C	Normal control	Control dependent on the values of Pc and Pe (→ Low pressure protection control)	Normal control from current rps
Outdoor fan	M1F	M1F	M1F M2F	Fan control (Normal cooling)	Fan control (Normal cooling)	Fan control (Normal cooling)
Electronic expansion valve (Main)	Y1E	Y1E	Y1E	480 pulse (Fully open)	480 pulse (Fully open)	480 pulse (Fully open)
Electronic expansion valve (Subcooling)	—	—	Y3E	SH control	0 pulse	0 pulse
Four way valve	Y1S	Y1S	Y1S	OFF	OFF	OFF
Hot gas bypass valve	Y2S	—	—	OFF	OFF	OFF
Injection valve	Y3S	Y3S	—	OFF	OFF	OFF
Ending conditions				15 seconds	• 3 minutes • Ts1–Te < 3°C (5.4°F) • A lapse of 20 minutes • System rps is large than oil return rps for more than 6 minutes.	OR ( <ul style="list-style-type: none"> <li>• 3 minutes</li> <li>• Pe &lt; 0.6 MPa (87 psi)</li> <li>• HTdi &gt; 110°C (230°F)</li> <li>• Pc &gt; 3.6 MPa (522 psi)</li> </ul> )

Indoor unit actuator		Cooling oil return control
Fan	Thermostat ON unit	Remote controller setting
	Non-operating unit	OFF
	Thermostat OFF unit	Remote controller setting
Electronic expansion valve	Thermostat ON unit	Normal opening
	Non-operating unit	224 pulse
	Thermostat OFF unit	Normal opening with forced thermostat ON

### 3.2.2 Oil Return Control in Heating

Pc: High pressure sensor detection value  
 Pe: Low pressure sensor detection value  
 Tc: High pressure equivalent saturation temperature  
 Te: Low pressure equivalent saturation temperature  
 Ts1: Suction pipe temperature detected by thermistor R3T  
 Tb: Heat exchanger temperature

#### Starting Conditions

- Oil return operation is not conducted before 2 hours have elapsed from the activation of power supply.
- After 2 hours have elapsed, oil return operation starts when the following item meets the reference value.
  - ◆ Total amount of oil discharged from the compressor (The total amount of oil discharged from the compressor is computed from Tc, Te, and compressor loads.)
- Oil return operation starts every 8 hours of cumulative operation of the compressor, even if the reference value is not met.

Outdoor unit actuator	Electric symbol			(A) Oil return preparation control	(B) Oil return control	(C) Control after oil return
	24/36 class	48 class	60 class			
Compressor	M1C	M1C	M1C	Upper limit control → 0 rps	STEP 25 load (24/36 class) STEP 21 load (48/60 class)	Increases 2 steps every 20 seconds from minimum frequency until Pc – Pe > 0.4 MPa (58 psi) is achieved.
Outdoor fan	M1F	M1F	M1F M2F	Fan control (Normal heating)	Control dependent on the values of Pc from STEP 3	OFF → STEP 8 after Pc – Pe > 0.4 MPa (58 psi)
Electronic expansion valve (Main)	Y1E	Y1E	Y1E	SH control → 0 pulse	480 pulse (Fully open)	55 pulse
Electronic expansion valve (Subcooling)	—	—	Y3E	Normal control → 0 pulse	0 pulse	0 pulse
Four way valve	Y1S	Y1S	Y1S	ON	OFF	ON
Hot gas bypass valve	Y2S	—	—	OFF (Up to 5 minutes 50 seconds)	OFF	ON → OFF
Injection valve	Y3S	Y3S	—	OFF	OFF	OFF
Ending conditions				OR ( <ul style="list-style-type: none"> <li>• More than 4 minutes 30 seconds</li> <li>• A lapse of 20 seconds from four way valve ON → OFF</li> </ul>	OR ( <ul style="list-style-type: none"> <li>• 16 minutes</li> <li>&amp; (                             <ul style="list-style-type: none"> <li>• Tb &gt; 11°C (51.8°F)</li> <li>• Ts1 – Te &lt; 5°C (9°F)</li> </ul> </li> </ul>	OR ( <ul style="list-style-type: none"> <li>• 160 seconds</li> <li>• Pc &gt; 2.7 MPa (391 psi)</li> <li>• Pc – Pe &gt; 0.4 MPa (58 psi)</li> </ul>

\* Between (A) oil return preparation control and (B) oil return control, and between (B) oil return control and (C) control after oil return, the compressor stops for 1 minute to reduce noise on changing of the four way valve.

Indoor unit actuator		Heating oil return control
Fan	Thermostat ON unit	OFF
	Non-operating unit	OFF
	Thermostat OFF unit	OFF
Electronic expansion valve	Thermostat ON unit	416 pulse
	Non-operating unit	256 pulse
	Thermostat OFF unit	416 pulse

### 3.3 Defrost Control

Pc: High pressure sensor detection value

Pe: Low pressure sensor detection value

Tb: Heat exchanger deicer temperature

Tc: High pressure equivalent saturation temperature

Te: Low pressure equivalent saturation temperature

Ts1: Suction pipe temperature detected by thermistor R3T

Defrost control is performed to melt frost on the outdoor heat exchanger when heating, and thus recover heating capacity.

#### Starting Conditions

- Defrost operation is not conducted before 40 minutes have elapsed from the start of heating operation.
- After 40 minutes have elapsed, defrost operation starts when the following items meet the reference values.
  - ◆ Heat transfer coefficient of the outdoor heat exchanger (The heat transfer coefficient of the outdoor heat exchanger is computed from Tc, Te, and compressor loads.)
  - ◆ Outdoor heat exchanger deicer temperature (Tb)
- Defrost operation starts every 2 hours, even if the reference values are not met.

Outdoor unit actuator	Electric symbol			(A) Defrost preparation control	(B) Defrost control	(C) Control after defrost
	24/36 class	48 class	60 class			
Compressor	M1C	M1C	M1C	Upper limit control → 0 rps	STEP 25 load (24/36 class) STEP 21 load (48/60 class)	Increases 2 steps every 20 seconds from minimum frequency until $P_c - P_e > 0.4 \text{ MPa}$ (58 psi) is achieved.
Outdoor fan	M1F	M1F	M1F M2F	Normal heating control → OFF	OFF	STEP 8
Electronic expansion valve (Main)	Y1E	Y1E	Y1E	SH control → 0 pulse	480 pulse (Fully open)	55 pulse
Electronic expansion valve (Subcooling)	—	—	Y3E	Normal heating control → 0 pulse	0 pulse	0 pulse
Four way valve	Y1S	Y1S	Y1S	ON → OFF	OFF	ON
Hot gas bypass valve	Y2S	—	—	OFF → ON	OFF	ON → OFF
Injection valve	Y3S	Y3S	—	OFF	OFF	OFF
Ending conditions				OR ( <ul style="list-style-type: none"> <li>• Up to 5 minutes 50 seconds</li> <li>• A lapse of 20 seconds from four way valve ON → OFF</li> </ul>	OR ( <ul style="list-style-type: none"> <li>• 16 minutes</li> <li>• <math>T_b &gt; 11^\circ\text{C}</math> (51.8°F)</li> <li>&amp; <math>T_{s1} - T_e &lt; 5^\circ\text{C}</math> (9°F)</li> </ul>	OR ( <ul style="list-style-type: none"> <li>• 260 seconds</li> <li>• <math>P_c &gt; 2.7 \text{ MPa}</math> (391 psi)</li> <li>• <math>P_c - P_e &gt; 0.4 \text{ MPa}</math> (58 psi)</li> </ul>

\* Between (A) defrost preparation control and (B) defrost control, and between (B) defrost control and (C) control after defrost, the compressor stops for 1 minute to reduce noise on changing of the four way valve.

Indoor unit actuator		Defrost control
Fan	Thermostat ON unit	OFF
	Non-operating unit	OFF
	Thermostat OFF unit	OFF
Electronic expansion valve	Thermostat ON unit	416 pulse
	Non-operating unit	256 pulse
	Thermostat OFF unit	416 pulse

## 3.4 Pump Down Residual Control

If liquid refrigerant is retained in the evaporator when the compressor is activated, the liquid refrigerant enters the compressor and dilutes oil therein resulting in a decrease of lubricity. Therefore, pump down residual control is performed to collect the refrigerant retained in the evaporator when the compressor stops.

### 3.4.1 Pump Down Residual Control in Cooling

Outdoor unit actuator	Electric symbol			Pump down residual control	
	24/36 class	48 class	60 class	Step 1	Step 2
Compressor	M1C	M1C	M1C	STEP 18 load (24/36 class) 58 rps (48/60 class)	STEP 6 load (24/36 class) 24 rps (48/60 class)
Outdoor fan	M1F	M1F	M1F M2F	Fan control	Fan control
Electronic expansion valve (Main)	Y1E	Y1E	Y1E	480 pulse (Fully open)	240 pulse (Half open) (24/36 class) 480 pulse (Fully open) (48/60 class)
Electronic expansion valve (Subcooling)	—	—	Y3E	0 pulse	0 pulse
Four way valve	Y1S	Y1S	Y1S	OFF	OFF
Hot gas bypass valve	Y2S	—	—	OFF	OFF
Injection valve	Y3S	Y3S	—	OFF	OFF
Ending conditions				2 seconds	2 seconds

### 3.4.2 Pump Down Residual Control in Heating

Outdoor unit actuator	Electric symbol			Pump down residual control
	24/36 class	48 class	60 class	
Compressor	M1C	M1C	M1C	STEP 18 load (24/36 class) STEP 9 load (48/60 class)
Outdoor fan	M1F	M1F	M1F M2F	STEP 7
Electronic expansion valve (Main)	Y1E	Y1E	Y1E	0 pulse
Electronic expansion valve (Subcooling)	—	—	Y3E	0 pulse
Four way valve	Y1S	Y1S	Y1S	ON
Hot gas bypass valve	Y2S	—	—	OFF
Injection valve	Y3S	Y3S	—	OFF
Ending conditions				4 seconds (24/36 class) Up to 3 minutes (48/60 class)



### 3.5 Restart Standby

Restart is forced into standby to prevent the power from frequently turning on and off and to equalize pressure in the refrigerant system.

Ta: Outdoor air temperature

Outdoor unit actuator	Electric symbol			Operation
	24/36 class	48 class	60 class	
Compressor	M1C	M1C	M1C	OFF
Outdoor fan	M1F	M1F	M1F M2F	Ta > 30°C (86°F): STEP 4 Ta ≤ 30°C (86°F): OFF
Electronic expansion valve (Main)	Y1E	Y1E	Y1E	0 pulse
Electronic expansion valve (Subcooling)	—	—	Y3E	0 pulse
Four way valve	Y1S	Y1S	Y1S	Holds
Hot gas bypass valve	Y2S	—	—	ON
Injection valve	Y3S	Y3S	—	OFF
Ending conditions				2 minutes

### 3.6 Stop Control

Actuator operation is cleared when the system is down.

Outdoor unit actuator	Electric symbol			Operation
	24/36 class	48 class	60 class	
Compressor	M1C	M1C	M1C	OFF
Outdoor fan	M1F	M1F	M1F M2F	OFF
Electronic expansion valve (Main)	Y1E	Y1E	Y1E	0 pulse
Electronic expansion valve (Subcooling)	—	—	Y3E	0 pulse
Four way valve	Y1S	Y1S	Y1S	Holds
Hot gas bypass valve	Y2S	—	—	OFF
Injection valve	Y3S	Y3S	—	OFF
Ending conditions				Indoor unit thermostat is turned ON.

# 4. Protection Control

## 4.1 High Pressure Protection Control

This high pressure protection control is used to prevent the activation of protection devices due to an abnormal increase of high pressure and to protect compressors against the transient increase of high pressure.

Pc: High pressure sensor detection value

### Cooling Operation

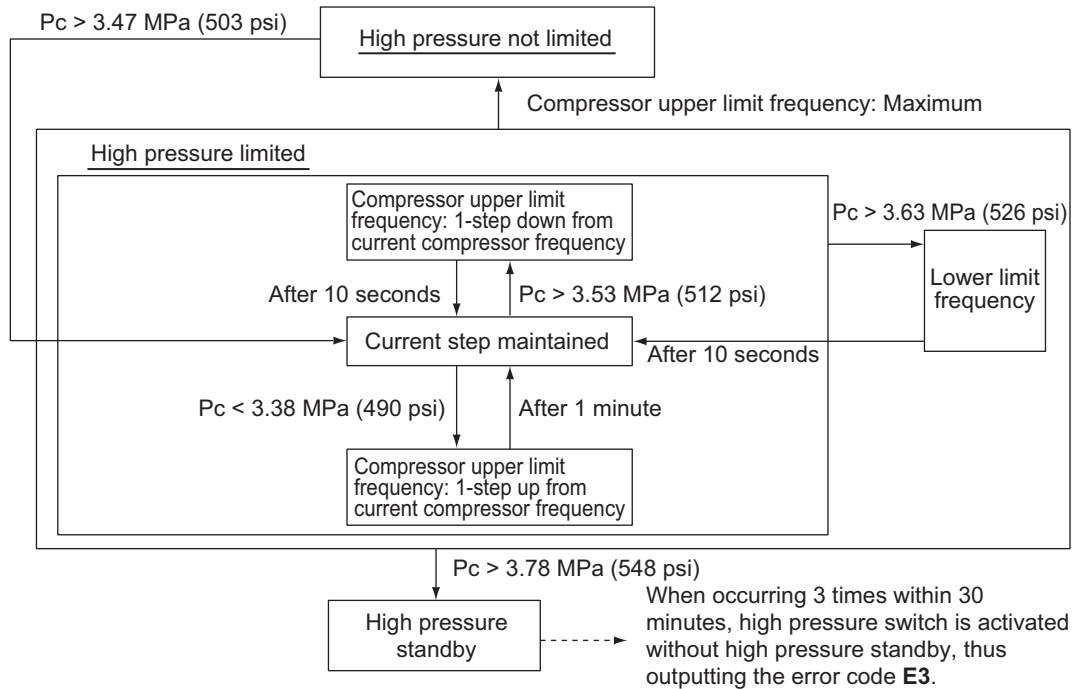

### Heating Operation

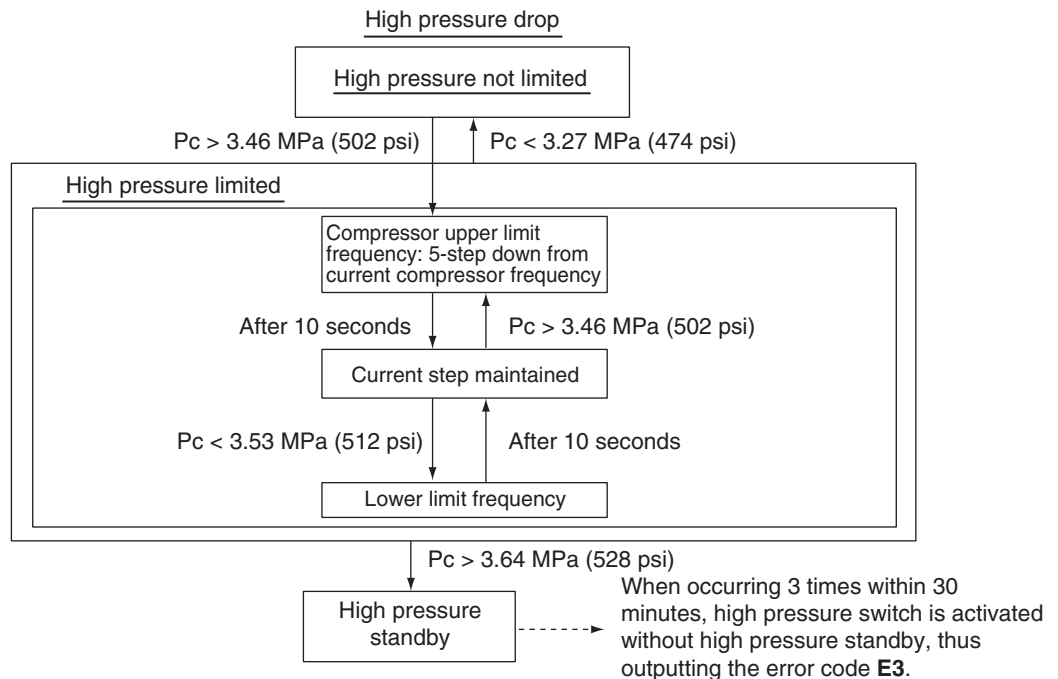

## 4.2 Low Pressure Protection Control

This low pressure protection control is used to protect compressors against the transient decrease of low pressure.

Pe: Low pressure sensor detection value

### Cooling Operation

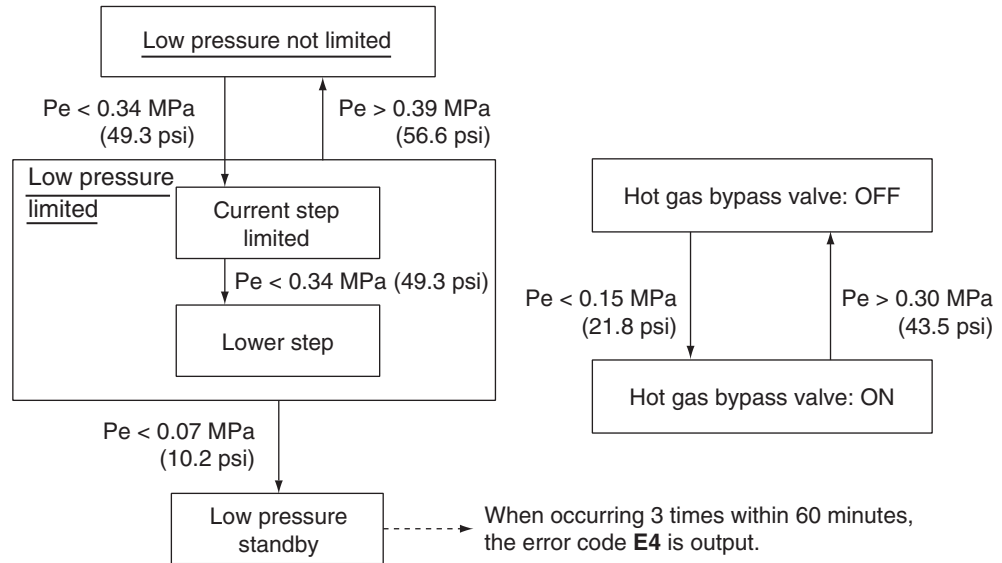

### Heating Operation

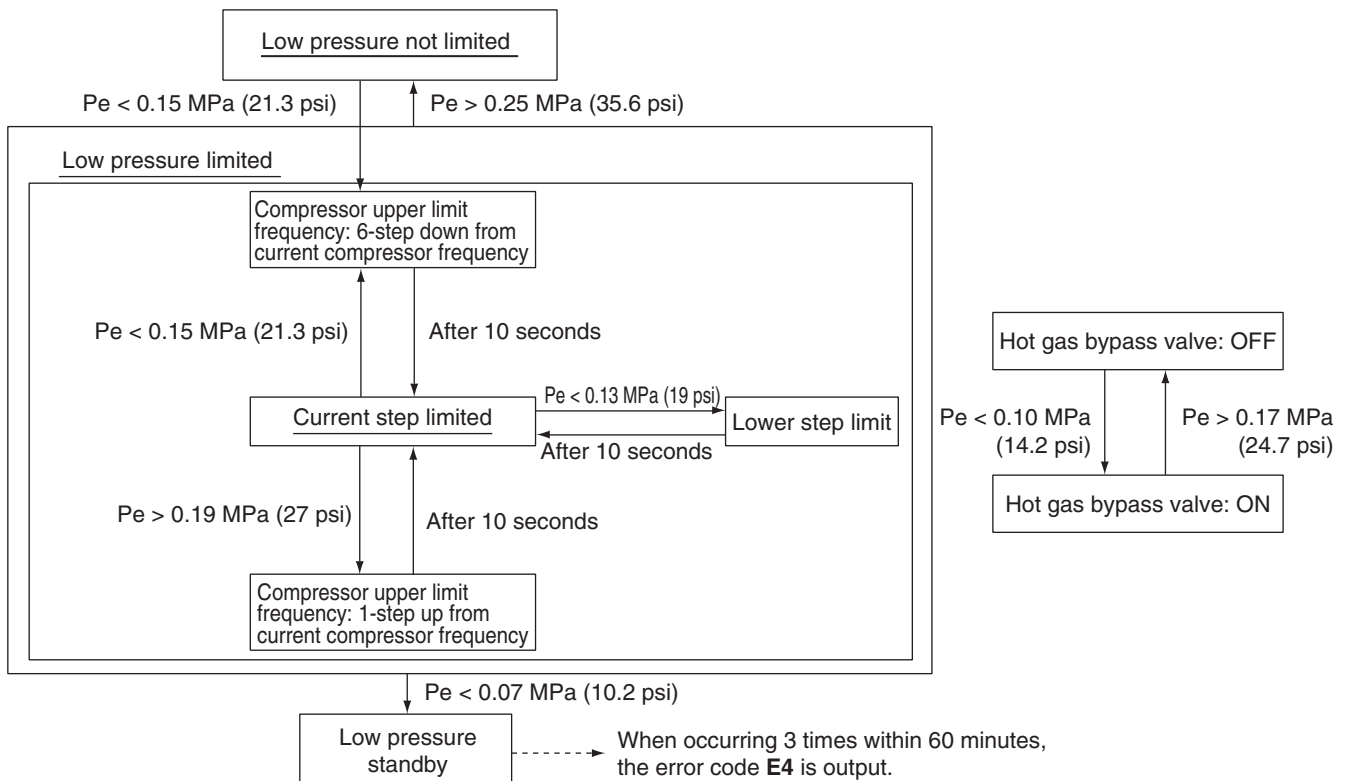

### 4.3 Discharge Pipe Temperature Protection Control

This discharge pipe temperature protection control is used to protect the compressor internal temperature against an error or transient increase of discharge pipe temperature.

HTdi: Value of inverter compressor discharge pipe temperature (Tdi) compensated with outdoor air temperature

Tp: Value of compressor port temperature calculated by Tc, Te, and suction superheating degree.

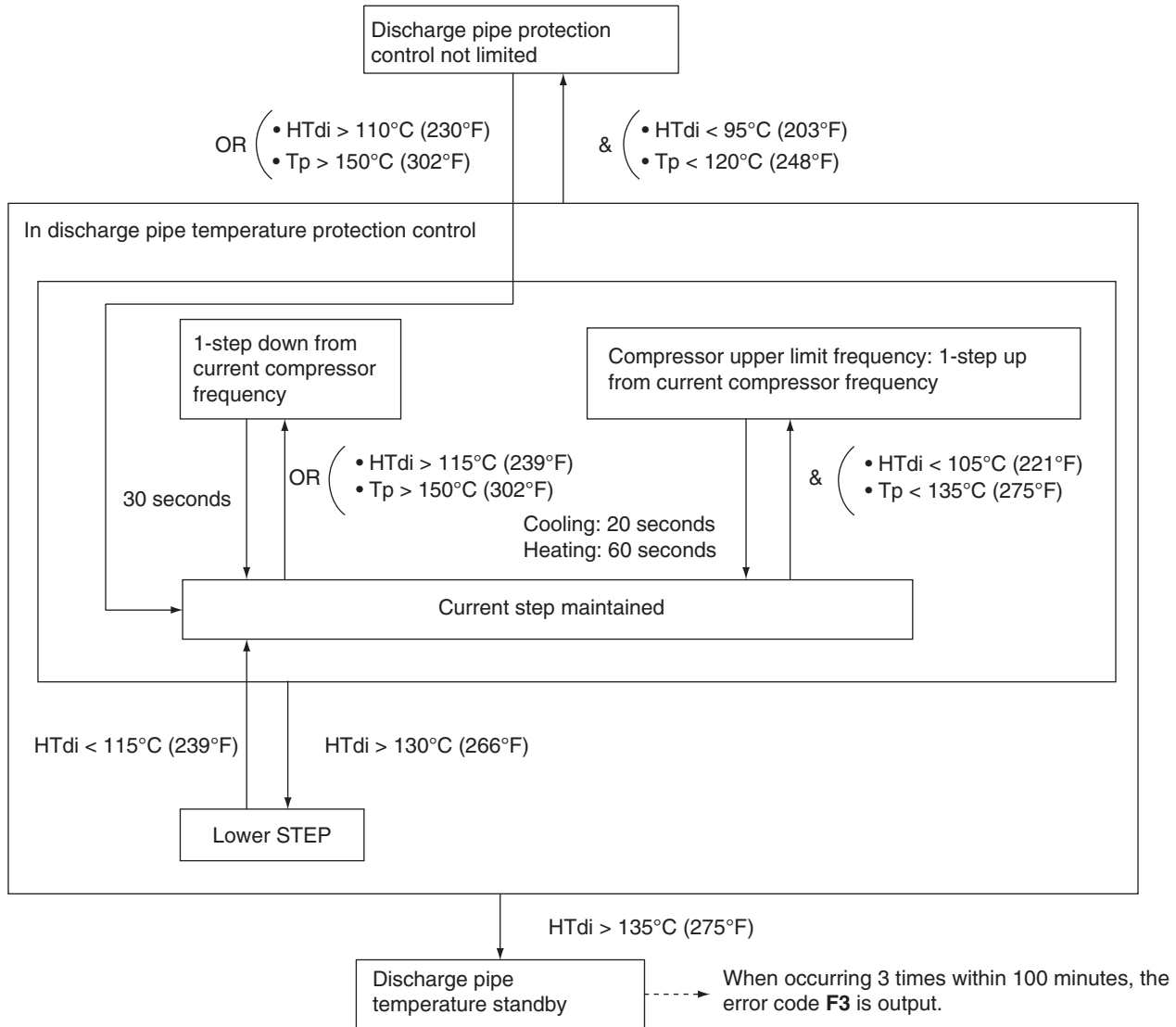

## 4.4 Inverter Protection Control

Inverter current protection control and radiation fin temperature control are performed to prevent tripping due to an error, or transient inverter overcurrent, and radiation fin temperature increase.  
 Tfin: Radiation fin temperature

### Inverter overcurrent protection control

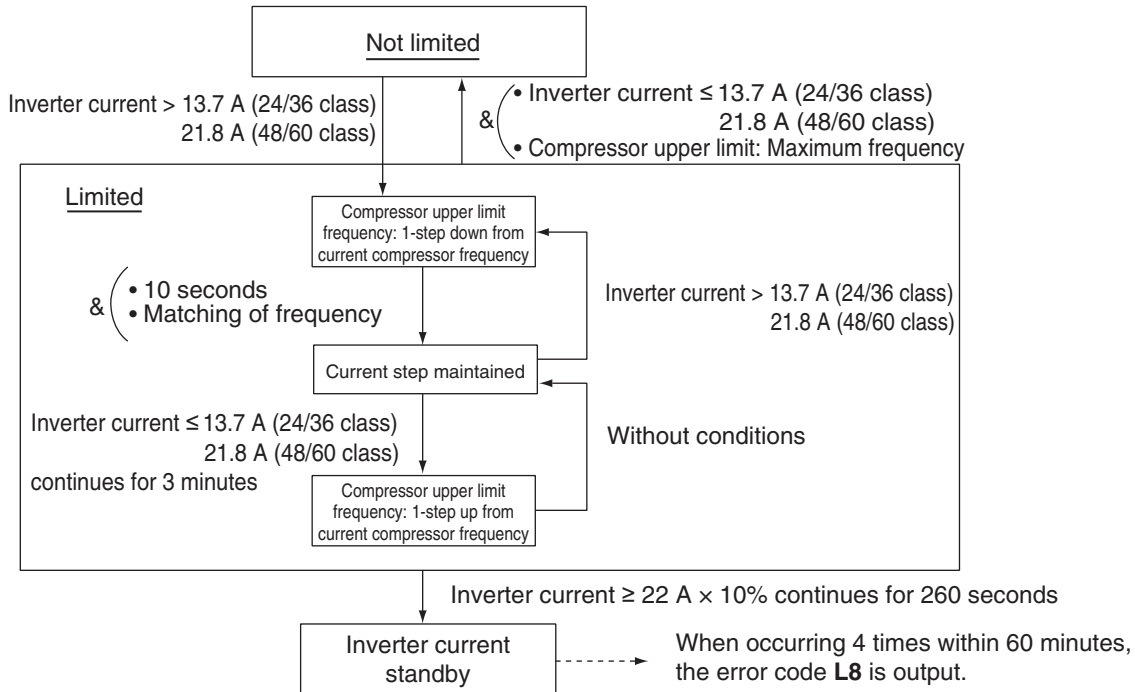

### Radiation fin temperature control

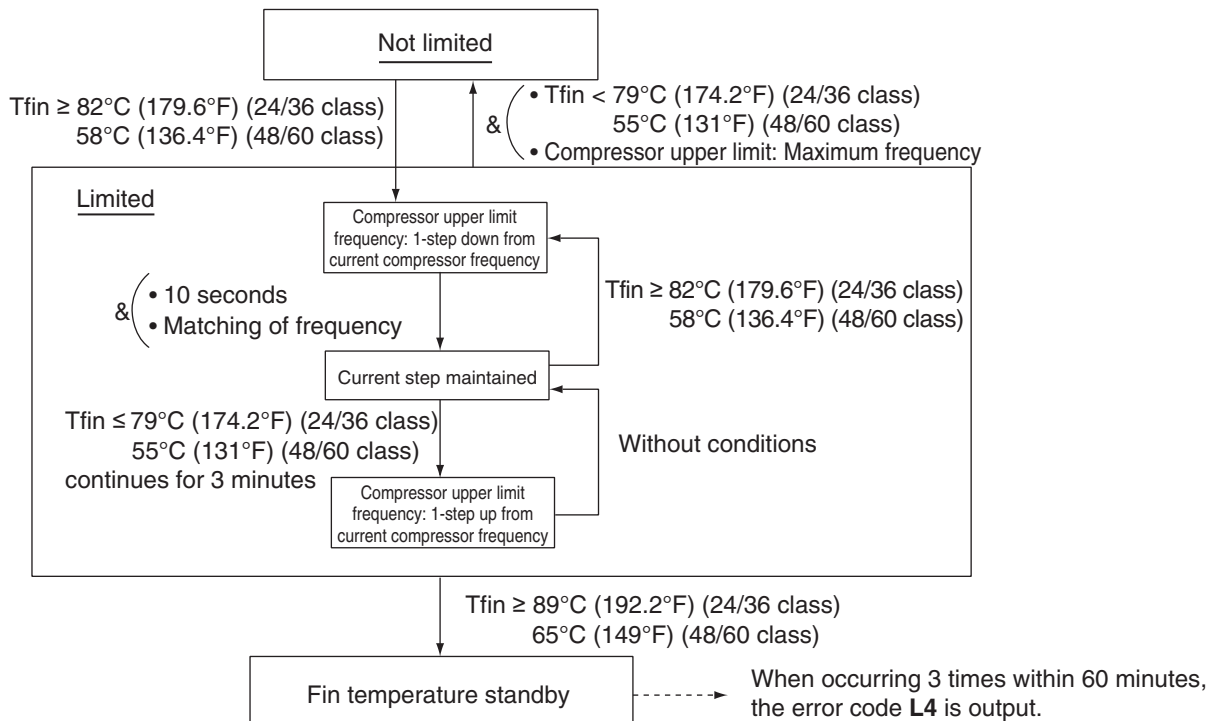

According to the current limit of direct current

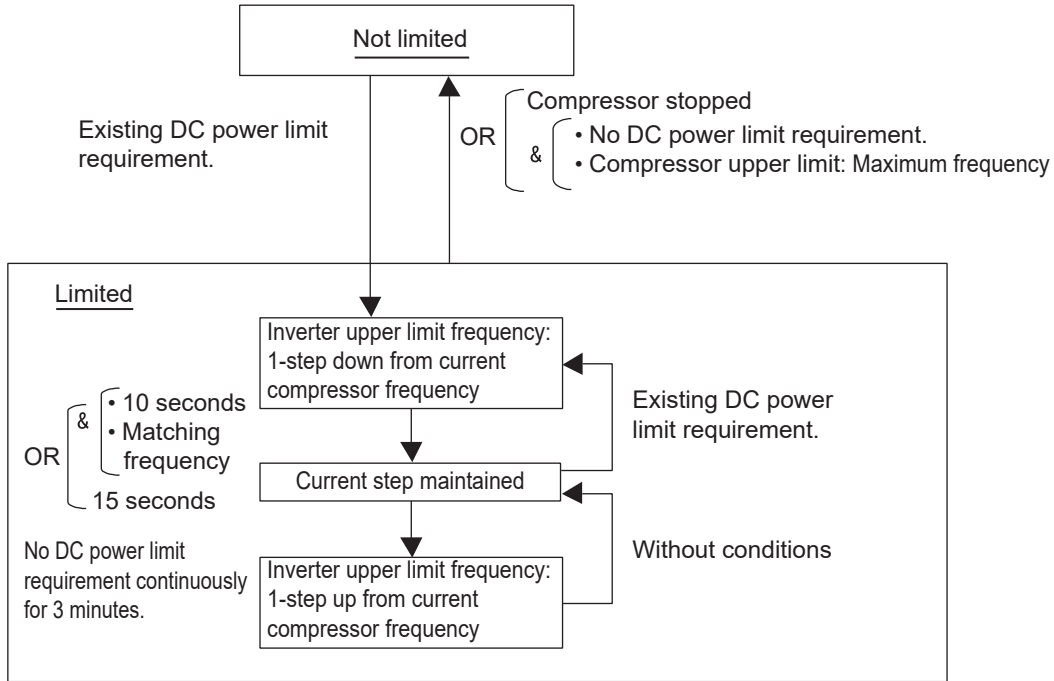

## 5. Other Control

### 5.1 Demand Operation

In order to reduce power consumption, the outdoor unit capacity is reduced forcibly with control by using Demand Setting 1.

To enable this operation, the additional setting of Constant Demand Setting is required.

#### Demand setting 1

Level	Standard for upper limit of power consumption
Level 1	Approx. 60%
Level 2 (Factory setting)	Approx. 70%
Level 3	Approx. 80%

\* Other protection control functions have precedence over the above operation.

### 5.2 Heating Operation Prohibition

Heating operation is prohibited above 24°CDB (75.2°FDB) outdoor air temperature.

### 5.3 Gas Furnace Operation Prohibition

When a gas furnace is connected, it cannot be operated in the following situations.

1. During defrosting (once in 4 hours)
2. During test operation
3. During refrigerant charge
4. During pump-down operation

### 5.4 Gas Furnace Operation Startup Prohibition

When a gas furnace is connected, it cannot be started up in the following situations.

1. During cooling operation
2. In heating operation, during the following conditions.
  - Heat pump startup control
  - 5 minutes after heat pump startup control ends
  - 5 minutes after heat pump defrost operation ends
  - Heat pump stop control

# 6. Outline of Control (Indoor Unit)

## 6.1 Operation Flowchart

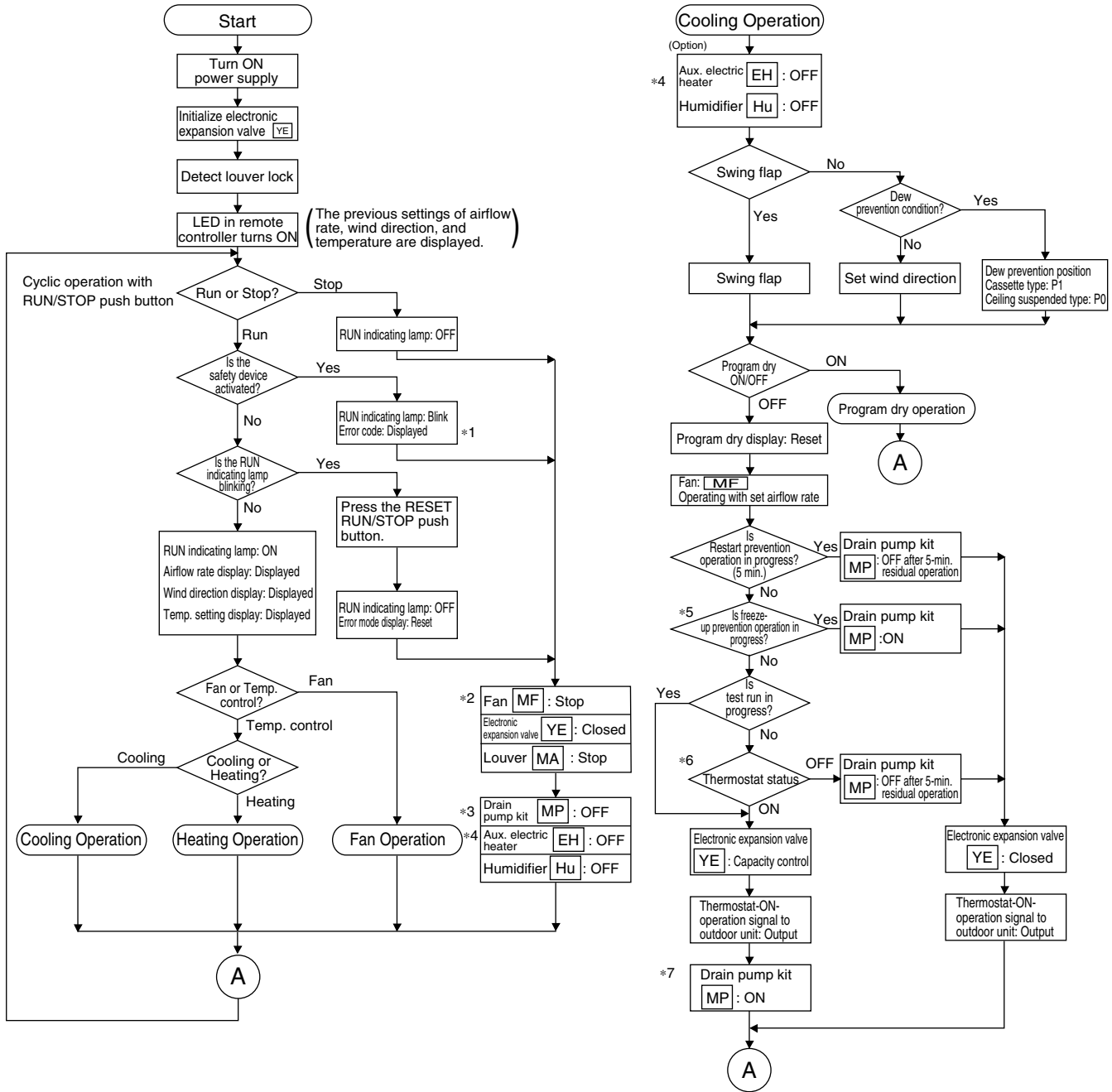



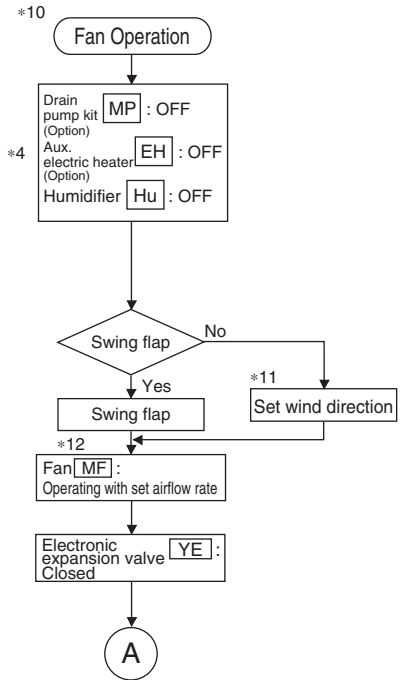
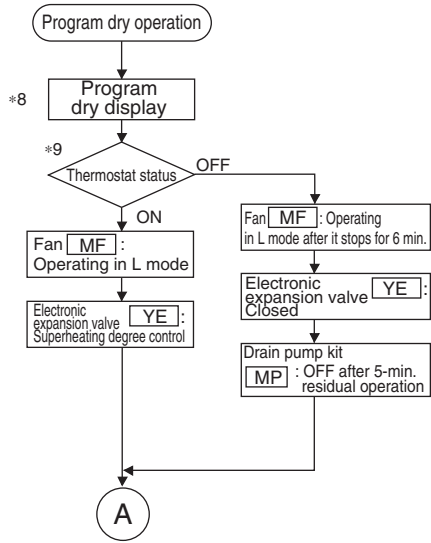

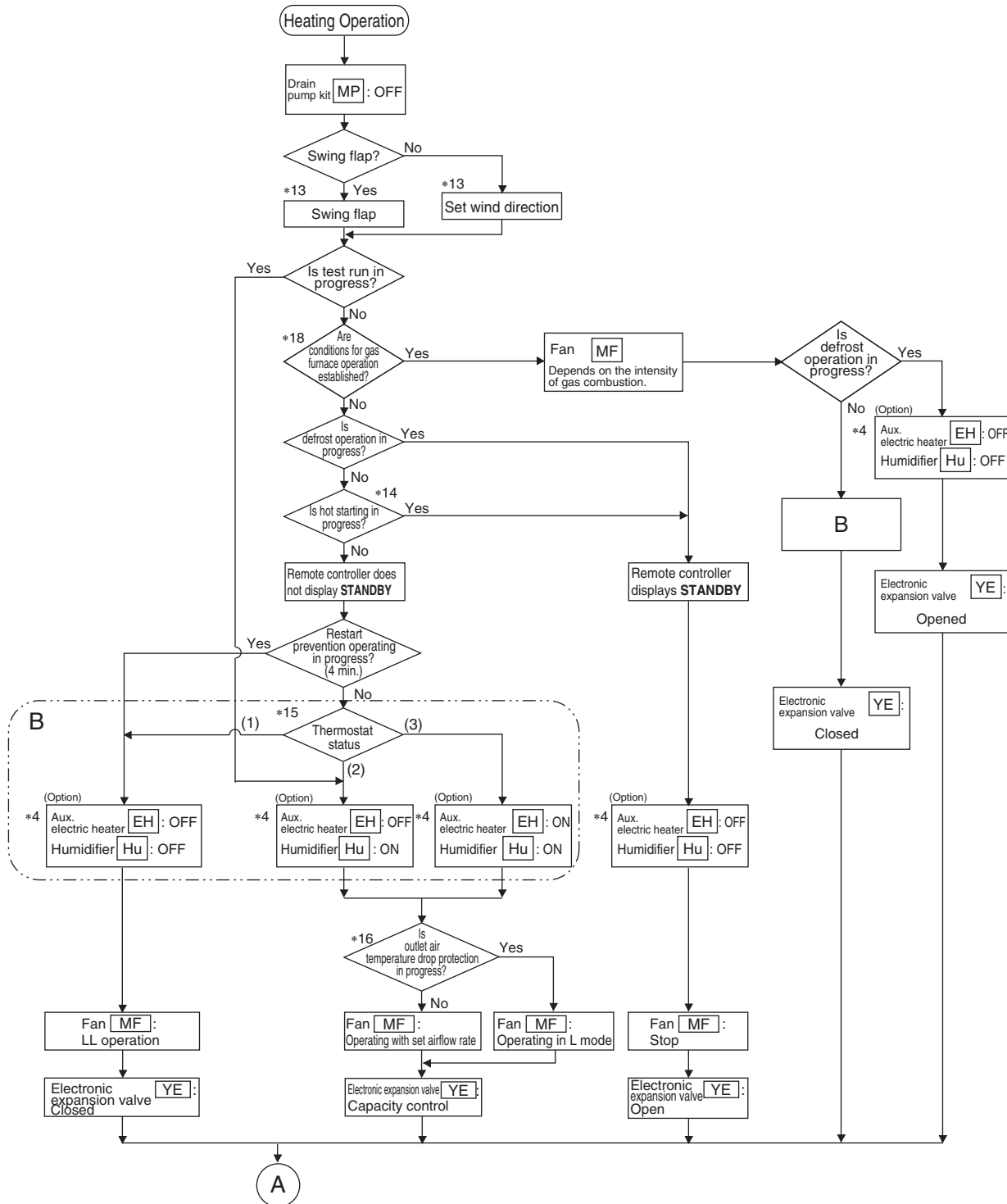

**i Note(s)**

- \*1. If any error occurs, the relevant error code will be displayed according to the error code display of the remote controller.
- \*2. When the auxiliary electric heater turns ON, the fan will stop after it conducts residual operation.
- \*3. When the drain pump kit turns ON, the drain pump kit will stop after it conducts residual operation for a period of 5 min.
- \*4. The control of auxiliary electric heater connected to FXTQ-TA models differ from this flowchart. For details, refer to **Heater Control (FXTQ-TA Models)** on page 117.
- \*5. If the evaporator inlet temperature is kept at not more than  $-5^{\circ}\text{C}$  ( $23^{\circ}\text{F}$ ) for a period of cumulative 10 min. or not more than  $-1^{\circ}\text{C}$  ( $30.2^{\circ}\text{F}$ ) for a cumulative period of 40 min., freeze-up

prevention operation will be conducted. If the evaporator inlet temperature is kept at not less than 7°C (44.6°F) for a consecutive period of 10 min., the freeze-up prevention operation will be reset.

\*6. Thermostat status

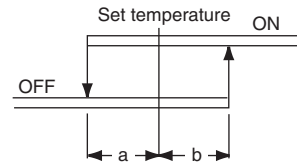

$a = b = 1^{\circ}\text{C} (1.8^{\circ}\text{F})$  or  $0.5^{\circ}\text{C} (0.9^{\circ}\text{F})$   
The values a and b depend on the field setting 12(22)-2.

\*7. The following models have the drain pump as standard equipment  
FXFQ-T, FXFQ-P, FXZQ-TA, FXZQ-TB, FXZQ-M, FXUQ-P, FXUQ-PA, FXEQ-P, FXDQ-M,  
FXSQ-TA, FXSQ-TB, FXMQ-PB, FXMQ-TB

\*8. Program dry display

No set temperature and airflow rate of the remote controller are displayed.

\*9. Thermostat status

Set temperature when operating the program dry mechanism.

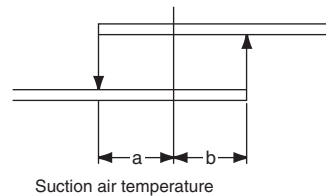

\*10. Fan operation

By setting the remote controller to Fan, the fan will operate with thermostat OFF in set temperature control operation mode.

\*11. Set wind direction

According to wind direction instruction from the remote controller, the wind direction is set to 100% horizontal while in heating operation.

\*12. Fan

According to fan speed instruction from the remote controller, the fan is put into operation in LL mode while in heating operation.

\*13. Wind direction

When the heating thermostat turns OFF, the wind direction will be set to 100% horizontal.

\*14. Hot start

After the start of heating operation or the end of defrost operation, the hot start control will terminate if the temperature at the condenser outlet (indoor heat exchanger liquid pipe temperature) exceeds 34°C (93.2°F), or if  $T_c$  is above 52°C (125.6°F), or if 3 minutes have elapsed.

\*15. Thermostat status

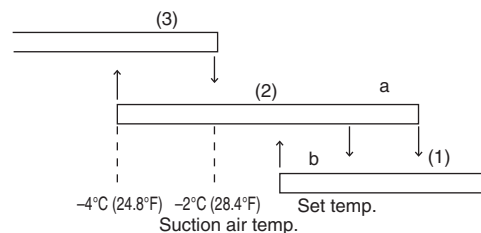

\*16. Outlet air temperature drop protection

When the set temperature is below 24°C (75.2°F) or the electronic expansion valve opening is small, the protection will be activated.

\*17. **Hu** indicates the Humidifier connected to the wiring modification adaptor.

It is not related to the Humidifier terminals on the PCB of FXTQ-TA or CXTQ-TA.

\*18. Only for CXTQ-TA.

Refer to **Gas Furnace Control (CXTQ-TA Models)** on page 120 for details.

## 6.2 Set Temperature and Control Target Temperature

### 6.2.1 Without Optional Infrared Floor Sensor

The relationship between remote controller set temperature and control target temperature is described below.

- ◆ When the suction air thermistor is used for controlling (Default), the control target temperature is determined as follows to prevent insufficient heating in heating operation.  
Control target temperature = remote controller displayed temperature + 2°C (3.6°F)
- ◆ The temperature difference for cooling ⇔ heating mode switching is 5°C (9°F).
- ◆ The above also applies to automatic operation.

#### ■ When setting the suction air thermistor (Default setting)

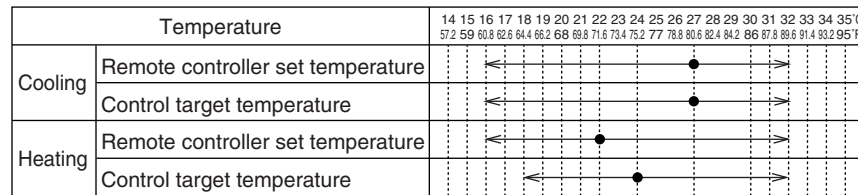

#### ■ When using the remote controller thermistor (Field setting is required)

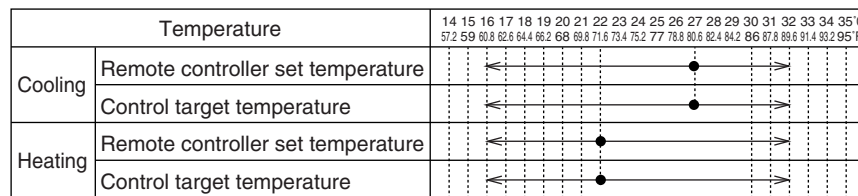

Examples are given to illustrate a control target temperature that satisfies the remote controller set temperature.

## 6.2.2 With Optional Infrared Floor Sensor

The relationship between remote controller set temperature and control target temperature is described below.

- ◆ The temperature difference for cooling ⇔ heating mode switching is 5°C (9°F).
- ◆ When using the floor temperature as the control target, the remote controller set temperature is equal to the actual control target temperature in heating operation.
- ◆ The above also applies to automatic operation.

### ■ When setting the suction air thermistor (Default setting)

Temperature		14	15	16	17	18	19	20	21	22	23	24	25	26	27	28	29	30	31	32	33	34	35	36
		57.2	59	60.8	62.6	64.4	66.2	68	69.8	71.6	73.4	75.2	77	78.8	80.6	82.4	84.2	86	87.8	89.6	91.4	93.2	95	96.8
Cooling	Remote controller set temperature	←-----●-----→																						
	Control target temperature	←-----●-----→																						
Heating	Remote controller set temperature	←-----●-----→																						
	Control target temperature	←-----●-----→																						

### ■ When using the remote controller thermistor (Field setting is required)

Temperature		14	15	16	17	18	19	20	21	22	23	24	25	26	27	28	29	30	31	32	33	34	35	36
		57.2	59	60.8	62.6	64.4	66.2	68	69.8	71.6	73.4	75.2	77	78.8	80.6	82.4	84.2	86	87.8	89.6	91.4	93.2	95	96.8
Cooling	Remote controller set temperature	←-----●-----→																						
	Control target temperature	←-----●-----→																						
Heating	Remote controller set temperature	←-----●-----→																						
	Control target temperature	←-----●-----→																						

Examples are given to illustrate a control target temperature that satisfies the remote controller set temperature.

### Regarding control target temperature

When using the infrared floor sensor, the temperature around people will be treated as the control target temperature for operation.

### What is the temperature around people?

The temperature around people refers to the temperature of the living space, obtained from the temperature around the ceiling and the temperature underfoot. The temperature is calculated using the detected values of the suction air thermistor and the infrared floor sensor.

It is difficult to use only suction air temperature control for underfoot air conditioning.

### 6.3 Remote Controller Thermistor

Temperature is controlled by both the remote controller thermistor and suction air thermistor for the indoor unit. (This is however limited to when the field setting for the remote controller thermistor is set to Use.)



**Note(s)**

When fresh air intake kit is used, outdoor air is mixed with indoor air, and the room temperature may not reach the set temperature, since TS and TH1 do not enter the area in which remote controller thermistor can be used. In such case, install the remote sensor (optional accessory) in your room, and set the field settings to not use the remote controller thermistor.

\* FXTQ-TA and CXTQ-TA models do not have this control because they do not have suction air thermistor. The thermistor is selectable manually when remote sensor (optional accessory) is installed.

**Cooling**

If there is a significant difference in the set temperature and the suction temperature, fine adjustment control is carried out using a suction air thermistor, or using the remote controller thermistor near the position of the user when the suction temperature is near the set temperature.

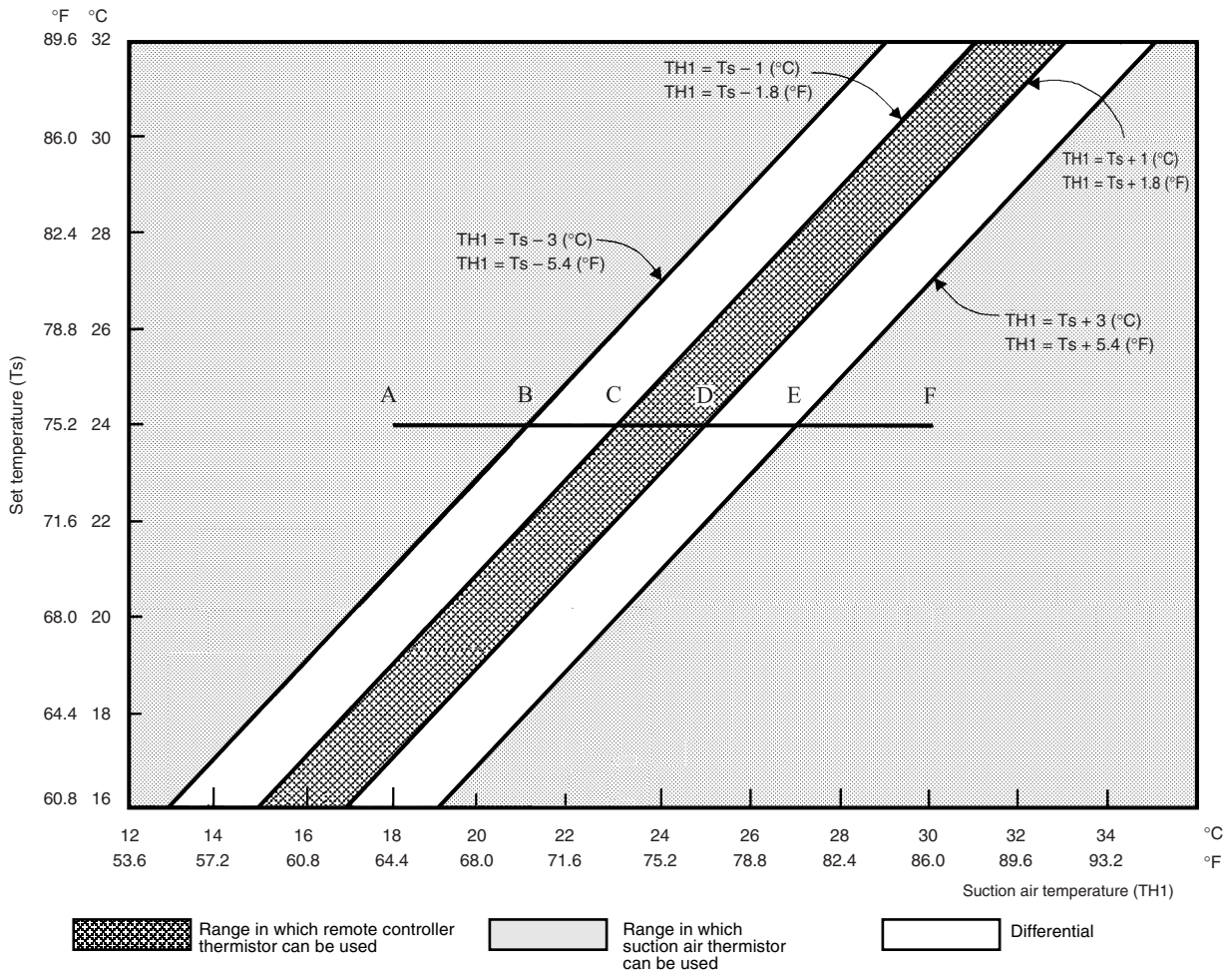

■ Assuming the set temperature in the figure above is 24°C (75°F), and the suction temperature has changed from 18°C (64°F) to 30°C (86°F) (A → F):

(This example also assumes there are several other air conditioners, and the suction temperature changes even when the thermostat is off.)

Suction air thermistor is used for temperatures from 18°C (64°F) to 23°C (73°F) (A → C).

Remote controller thermistor is used for temperatures from 23°C (73°F) to 27°C (81°F) (C → E).

Suction air thermistor is used for temperatures from 27°C (81°F) to 30°C (86°F) (E → F).

- Assuming suction temperature has changed from 30°C (86°F) to 18°C (64°F) (F → A):**  
 Suction air thermistor is used for temperatures from 30°C (86°F) to 25°C (77°F) (F → D).  
 Remote controller thermistor is used for temperatures from 25°C (77°F) to 21°C (70°F) (D → B).  
 Suction air thermistor is used for temperatures from 21°C (70°F) to 18°C (64°F) (B → A).

**Heating**

When heating, the hot air rises to the top of the room, resulting in the temperature being lower near the floor where the occupants are. When controlling by suction air thermistor only, the indoor unit may therefore be turned off by the thermostat before the lower part of the room reaches the set temperature. The temperature can be controlled so the lower part of the room where the occupants are does not become cold by widening the range in which remote controller thermistor can be used so that suction temperature is higher than the set temperature.

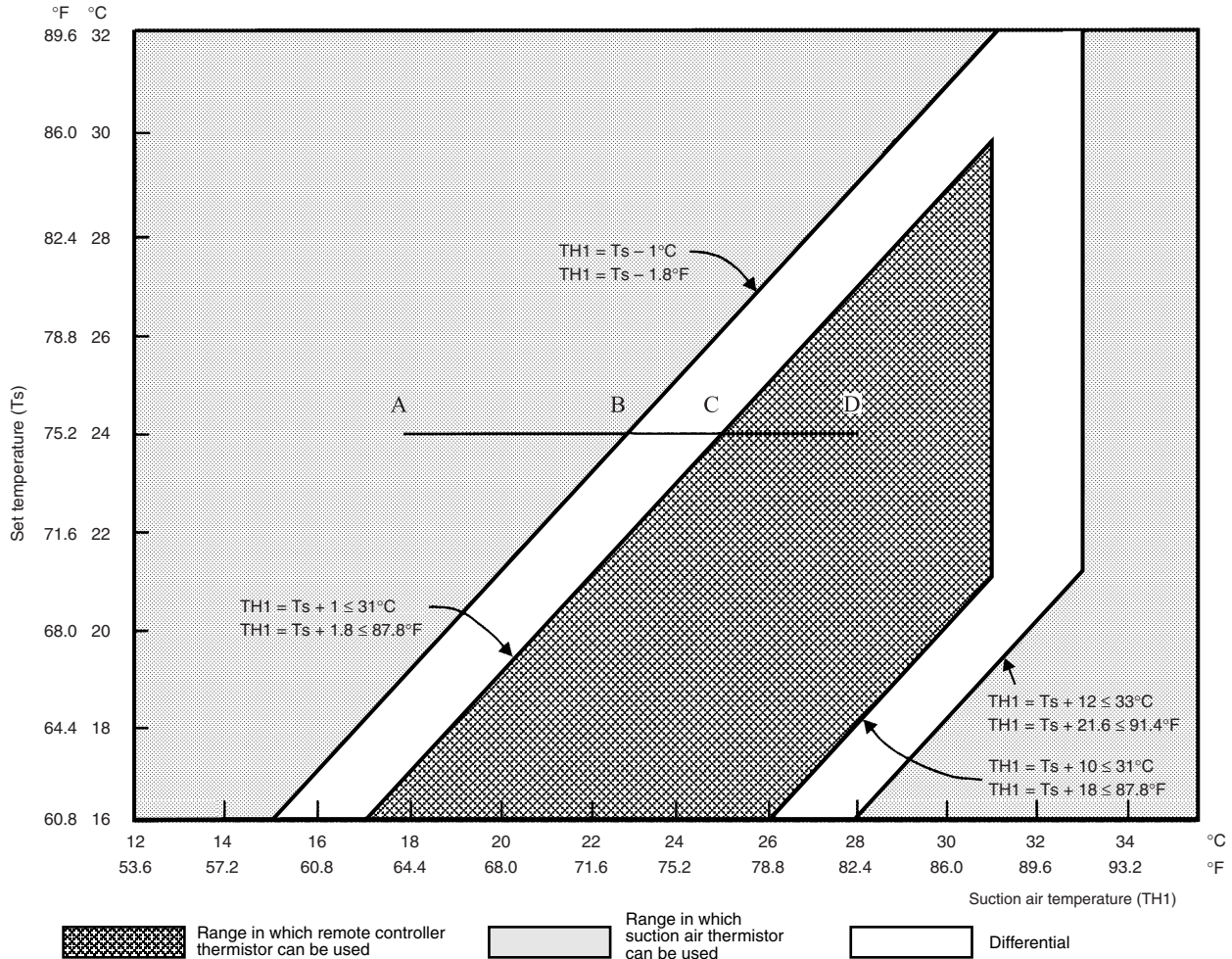

- Assuming the set temperature in the figure above is 24°C (75°F), and the suction temperature has changed from 18°C (64°F) to 28°C (82°F) (A → D):**  
 (This example also assumes there are several other air conditioners, and the suction temperature changes even when the thermostat sensor is off.)  
 Suction air thermistor is used for temperatures from 18°C (64°F) to 25°C (77°F) (A → C).  
 Remote controller thermistor is used for temperatures from 25°C (77°F) to 28°C (82°F) (C → D).
- Assuming suction temperature has changed from 28°C (82°F) to 18°C (64°F) (D → A):**  
 Remote controller thermistor is used for temperatures from 28°C (82°F) to 23°C (73°F) (D → B).  
 Suction air thermistor is used for temperatures from 23°C (73°F) to 18°C (64°F) (B → A).

## 6.4 Thermostat Control

### 6.4.1 Without Optional Infrared Floor Sensor

Whether the thermostat is turned ON or OFF is determined by the difference between the remote controller set temperature and the actual detected room temperature (\*1).

Differential value	Model
1°C (1.8°F)	FXFQ-T, FXFQ-P, FXZQ-TA, FXZQ-M, FXUQ-P, FXEQ-P, FXSQ-TA, FXHQ-M, FXTQ-TA
0.5°C (0.9°F)	FXZQ-TB, FXUQ-PA, FXDQ-M, FXSQ-TB, FXMQ-PB, FXMQ-TB, FXAQ-P, FXLQ-M, FXNQ-M, FXMQ-MF, CXTQ-TA

#### Normal operation

- ♦ Cooling operation

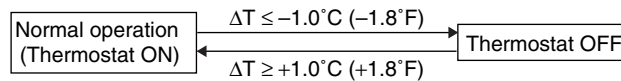

- ♦ Heating operation

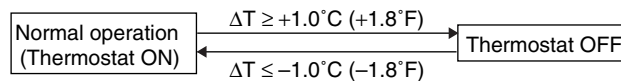

#### Dry operation

- ♦ When Tro < 24.5°C (76.1°F)

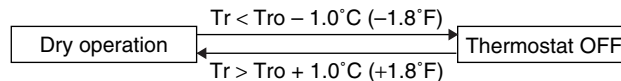

- ♦ When Tro ≥ 24.5°C (76.1°F)

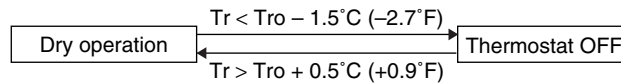

#### **FXZQ-TB, FXUQ-PA, FXSQ-TB, FXMQ-TB, FXTQ-TA, CXTQ-TA only**

If the field setting 11 (21)-12 (for FXZQ-TB, FXUQ-PA, FXSQ-TB, FXMQ-TB) or 14 (24)-5 (for FXTQ-TA, CXTQ-TA) is set to **02**, Tro will be the same as the cooling set temperature.

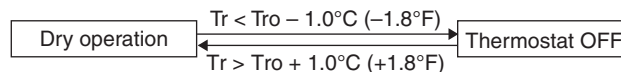

$\Delta T$  = Room temperature – Remote controller set temperature

Tro: Room temperature at the start of dry operation

Tr: Room temperature

\*1: The thermistor for room temperature detection depends on the field setting 10 (20)-2.



## 6.4.2 With Optional Infrared Floor Sensor

Whether the thermostat is turned on or off is determined by the difference between the remote controller set temperature and the detected temperature around people.

### Normal operation

- ♦ Cooling operation

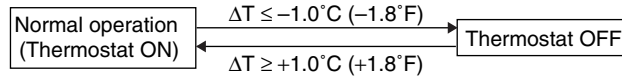

- ♦ Heating operation

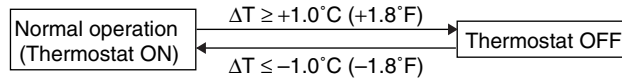

### Dry operation

- ♦ When  $T_{ro} \leq 24.5^{\circ}\text{C} (76.1^{\circ}\text{F})$

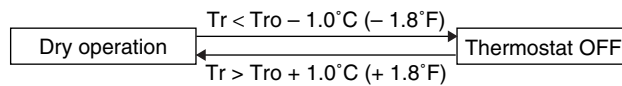

- ♦ When  $T_{ro} > 24.5^{\circ}\text{C} (76.1^{\circ}\text{F})$

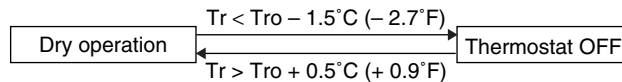

$\Delta T$  = Room temperature or temperature around people – Remote controller set temperature

$T_{ro}$ : Room temperature or temperature around people at the start of dry operation

$T_r$ : Room temperature or temperature around people

### Control range of temperature around people

When the floor temperature is very low, operation using the temperature around people may cause the suction air temperature to operate outside of use range.

To avoid the above condition, a limit based on the suction air temperature is set for the use range of the temperature around people.

#### Cooling operation

- ♦ When the floor temperature is lower than suction air temperature (R1T), R1T will be treated as the control target temperature for operation.
- ♦ When the temperature around people is  $15^{\circ}\text{C} (59^{\circ}\text{F})$  or lower, R1T will be treated as the control temperature for operation.

#### Heating operation

- ♦ When the floor temperature is higher than suction air temperature (R1T), R1T will be treated as the control target temperature in operation.
- ♦ When the temperature around people is  $33^{\circ}\text{C} (91.4^{\circ}\text{F})$  or higher, R1T will be treated as the control temperature for operation.

### 6.4.3 Thermostat Control with Operation Mode Set to AUTO

The system will conduct this temperature control shown below, only when the wireless remote controller or any central remote controller is connected.  
 Furthermore, setting changes of the differential value (D) can be made.

★: Factory setting

Mode No.	First code No.	Contents of setting	Second code No.							
			01★	02	03	04	05	06	07	08
12 (22)	4	Differential value while in AUTO operation mode	0°C 0°F ★	1°C 1.8°F	2°C 3.6°F	3°C 5.4°F	4°C 7.2°F	5°C 9.0°F	6°C 10.8°F	7°C 12.6°F

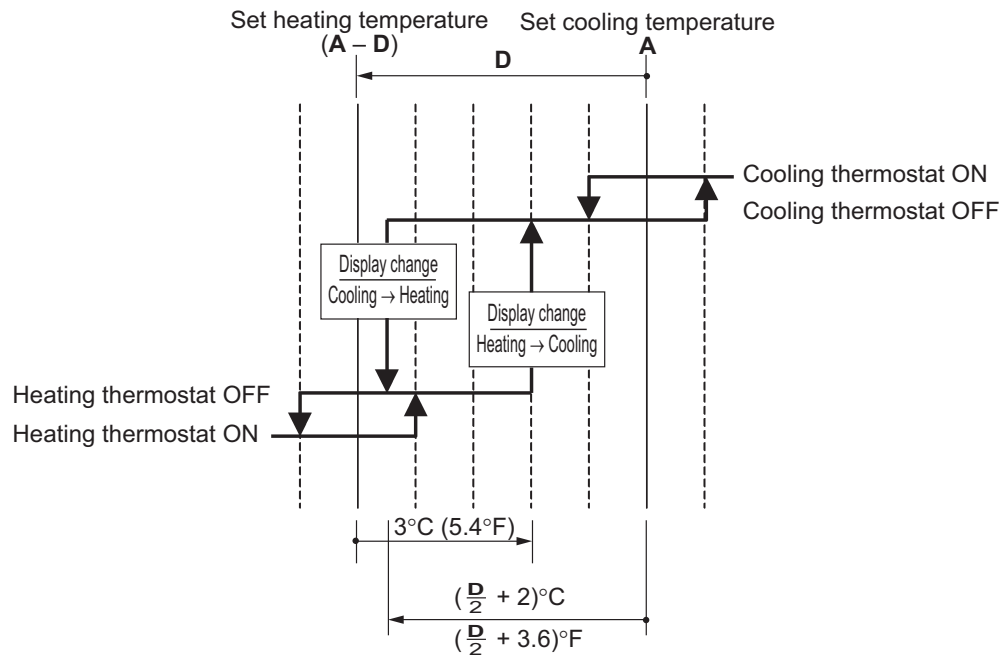

(Ex.) When automatic cooling temperature is set to 27°C (80.6°F):

Differential value: 0°C (0°F)

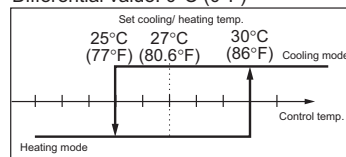

Differential value set to 4°C (7.2°F)

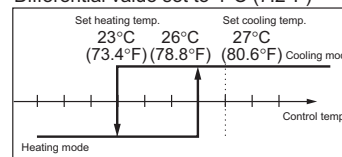

Differential value set to 1°C (1.8°F)

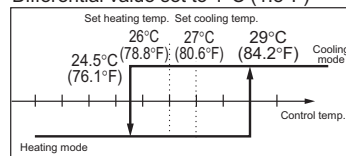

Differential value set to 5°C (9°F)

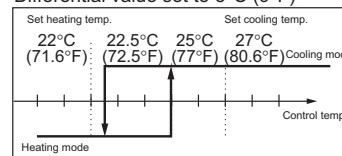

Differential value set to 2°C (3.6°F)

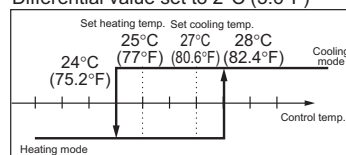

Differential value set to 6°C (10.8°F)

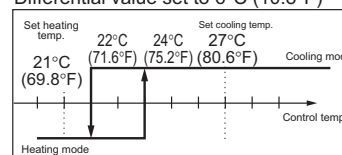

Differential value set to 3°C (5.4°F)

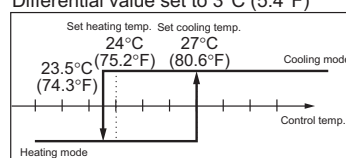

Differential value set to 7°C (12.6°F)

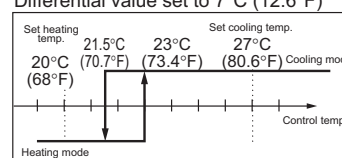

## 6.5 Drain Pump Control

### 6.5.1 Normal Operation

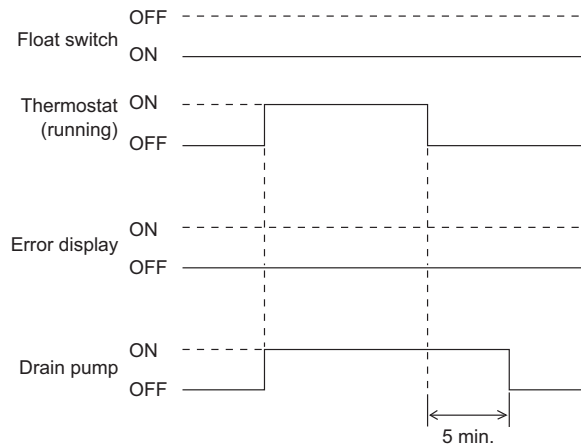

- ◆ The float switch is ON in normal operation.
- ◆ When cooling operation starts (thermostat ON), the drain pump turns ON simultaneously.
- ◆ After the thermostat turns OFF, the drain pump continues to operate for another 5 minutes.
- ◆ The aim of residual operation after thermostat OFF is to eliminate the dew that condenses on the indoor heat exchanger during cooling operation.

### 6.5.2 If the Float Switch is OFF with the Thermostat ON in Cooling Operation

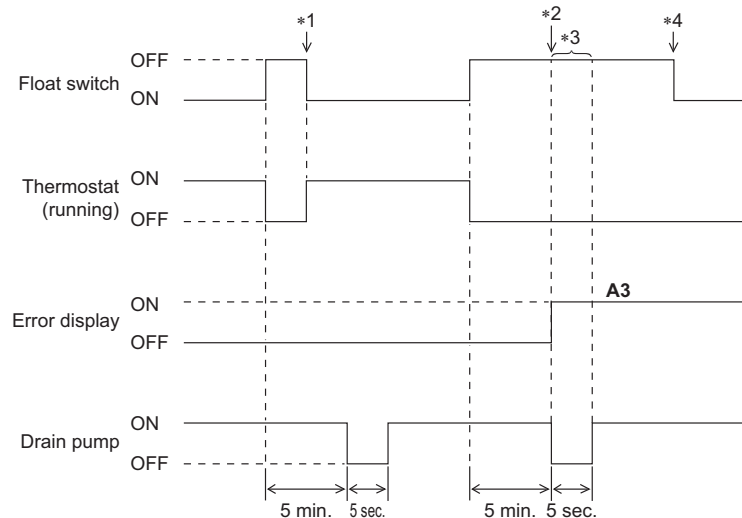

- ◆ When the float switch turns OFF, the thermostat turns OFF simultaneously.
- ◆ After the thermostat turns OFF, the drain pump continues to operate for another 5 minutes.
- \*1. If the float switch turns ON again during the residual operation of the drain pump, cooling operation also turns on again (thermostat ON).
- \*2. If the float switch remains OFF even after the residual operation of the drain pump has ended, the error code **A3** is displayed on the remote controller.
- \*3. The drain pump turns OFF once residual operation has ended, then turns ON again after 5 seconds.
- \*4. After **A3** is displayed and the unit comes to an abnormal stop, the thermostat will remain OFF even if the float switch turns ON again.

### 6.5.3 If the Float Switch is OFF with the Thermostat OFF in Cooling Operation

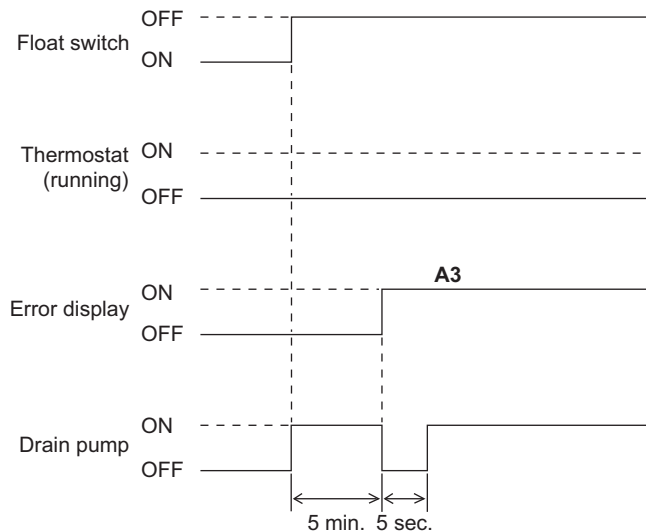

- ◆ When the float switch turns OFF, the drain pump turns ON simultaneously.
- ◆ If the float switch remains OFF even after the residual operation of the drain pump has ended, the error code **A3** is displayed on the remote controller.
- ◆ The drain pump turns OFF once residual operation has ended, then turns ON again after 5 seconds.

### 6.5.4 If the Float Switch Turns OFF and ON Continuously, or the Float Switch Turns OFF While AF Displayed

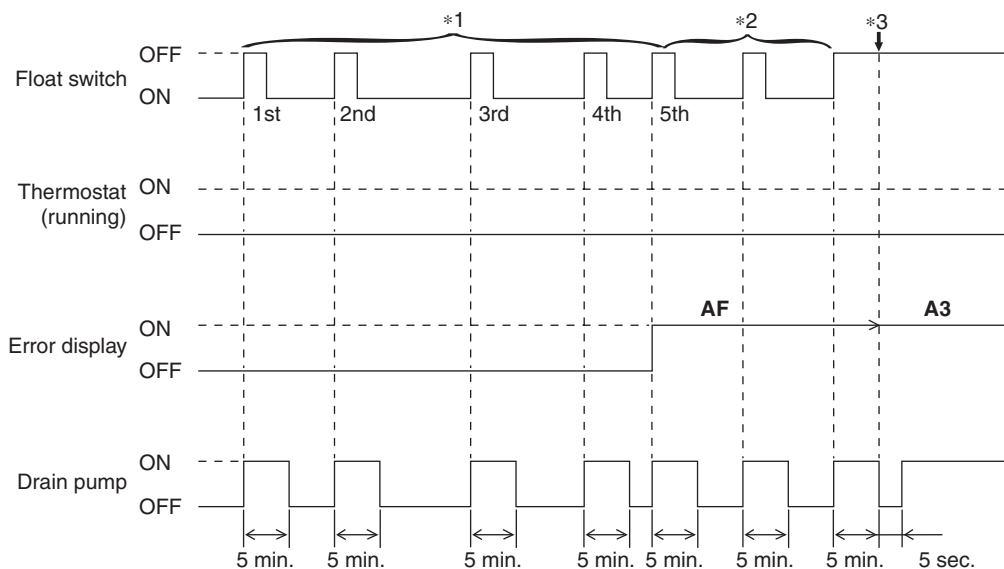

- ◆ When the float switch turns OFF, the drain pump turns ON simultaneously.
- \*1: If the float switch continues to turn OFF and ON 5 times consecutively, it is judged as a drain system error and the error code **AF** is displayed on the remote controller.
- \*2: The drain pump continues to turn ON/OFF in accordance with the float switch ON/OFF even after **AF** is displayed on the remote controller.
- \*3: While the error code **AF** is displayed, if the float switch remains OFF even after the residual operation of the drain pump has ended, the error code **A3** will be displayed on the remote controller.

## 6.6 Control of Electronic Expansion Valve

Electronic expansion valves in indoor units have the functions of conducting superheating degree control in cooling operation and subcooling degree control in heating operation. However, if the indoor units receive any control command such as a protection control command or a special control command from the outdoor unit, the units will give a priority to the control command.

### ● Superheating degree control in cooling operation

This function is used to adjust the opening of the electronic expansion valve so that superheating degree (SH), which is calculated from the detection temperature ( $T_g$ ) of the gas pipe thermistor (R3T) and the detection temperature (TI) of the liquid temperature thermistor (R2T) of the indoor unit, will come close to a target superheating degree (SHS).

At that time, correction to the superheating degree is made according to the differences ( $\Delta T$ ) between set temperature and suction air temperature.

$$SH = T_g - TI$$

Where,

SH: Evaporator outlet superheating degree

$T_g$ : Indoor unit gas pipe temperature (R3T)

TI: Indoor unit liquid pipe temperature (R2T)

SHS: Target superheating degree

SHS (Target SH value)

- ◆ Normally 5°C (9°F).
- ◆ As  $\Delta T$  (Remote controller set temp. – Suction air temp.) becomes larger, SHS becomes lower.
- ◆ As  $\Delta T$  (Remote controller set temp. – Suction air temp.) becomes smaller, SHS becomes higher.

### ● Subcooling degree control in heating operation

This function is used to adjust the opening of the electronic expansion valve so that the high pressure equivalent saturated temperature ( $T_c$ ), which is converted from the detected pressure of the high pressure sensor in the outdoor unit, and the subcooling degree (SC), which is calculated from the detected temperature (TI) of the liquid temperature thermistor (R2T) in the indoor unit, will come close to the target subcooling degree (SCS).

At that time, corrections to the subcooling degree are made according to differences ( $\Delta T$ ) between set temperature and suction air temperatures.

$$SC = T_c - TI$$

Where,

SC: Condenser outlet subcooling degree

$T_c$ : High pressure equivalent saturated temperature detected by the high pressure sensor (S1NPH)

TI: Indoor unit liquid pipe temperature (R2T)

SCS: Target subcooling degree

SCS (Target SC value)

- ◆ Normally 5°C (9°F).
- ◆ As  $\Delta T$  (Remote controller set temp. – Suction air temp.) becomes larger, SCS becomes lower.
- ◆ As  $\Delta T$  (Remote controller set temp. – Suction air temp.) becomes smaller, SCS becomes higher.

## 6.7 Freeze-Up Prevention

### Freeze-Up Prevention by Off Cycle (Indoor Unit)

When the temperature detected by the liquid pipe temperature thermistor of the indoor heat exchanger drops too low, the unit enters freeze-up prevention control in accordance with the following conditions, and is also set in accordance with the conditions given below. (Thermostat OFF)

When freeze-up prevention is activated, the electronic expansion valve is closed, the drain pump turns on and the airflow rate is fixed to L tap. When the following conditions for cancelling are satisfied, it will reset.

#### Conditions for starting:

Liquid pipe temperature  $\leq -1^{\circ}\text{C}$  ( $30.2^{\circ}\text{F}$ ) (for total of 40 minutes)

or

Liquid pipe temperature  $\leq -5^{\circ}\text{C}$  ( $23^{\circ}\text{F}$ ) (for total of 10 minutes)

#### Condition for cancelling:

Liquid pipe temperature  $\geq +7^{\circ}\text{C}$  ( $44.6^{\circ}\text{F}$ ) (for 10 minutes continuously)

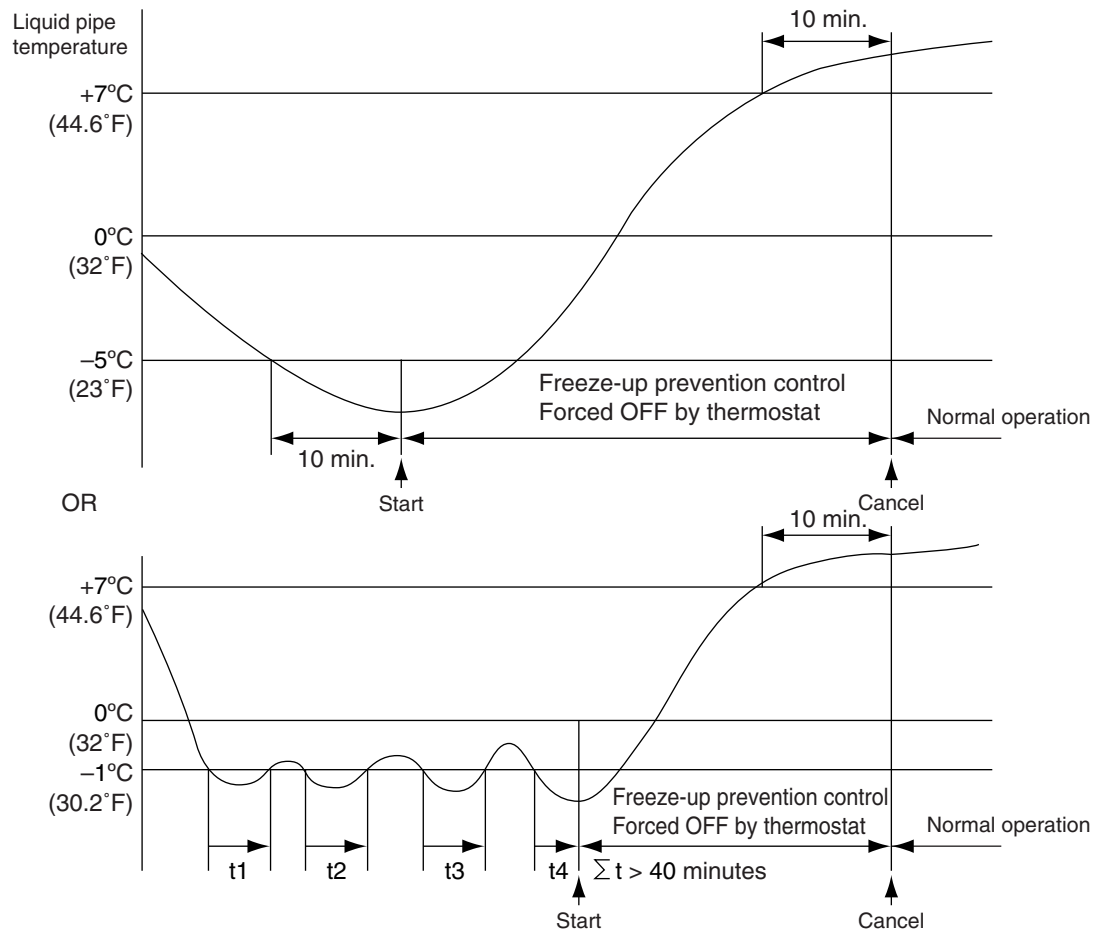

#### Concept of freeze-up prevention control

System avoids freeze-up

- For comfort, system avoids unnecessary thermostat ON/OFF
- For ensuring compressor reliability, system avoids unnecessary compressor ON/OFF

When freeze-up prevention control starts, system makes sure the frost is completely removed.

- System avoids water leakage.



**Note(s)**

When the indoor unit is FXFQ-T, FXFQ-P, FXZQ-TA, FXZQ-TB, FXZQ-M, FXUQ-P, or FXUQ-PA, if the air outlet is set as dual-directional or tri-directional, the starting conditions will be changed as follows.

Liquid pipe temperature  $\leq 1^{\circ}\text{C}$  (33.8°F) (for total of 15 minutes)

or

Liquid pipe temperature  $\leq 0^{\circ}\text{C}$  (32°F) (for 1 minute continuously)

During freeze-up prevention control, the airflow rate is fixed to LL.

(The cancelling conditions are same as the standard.)

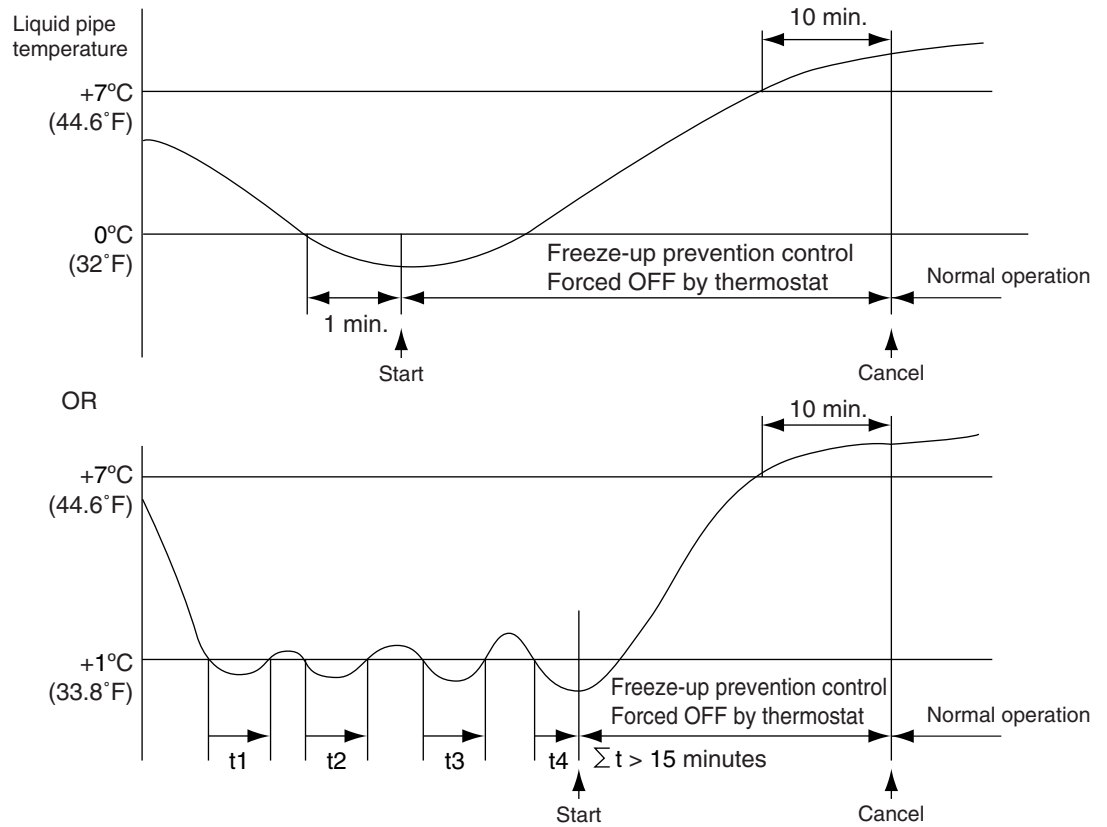

## 6.8 List of Swing Flap Operations

Swing flaps operate as shown in table below.

			Fan	Flap			
				FXFQ-T FXFQ-P	FXEQ-P	FXHQ-M	FXAQ-P
Heating	Hot start from defrost operation	Swing	OFF	Horizontal	Horizontal	Horizontal	Horizontal
		Airflow direction set	OFF	Horizontal	Horizontal	Horizontal	Horizontal
	Defrost operation	Swing	OFF	Horizontal	Horizontal	Horizontal	Horizontal
		Airflow direction set	OFF	Horizontal	Horizontal	Horizontal	Horizontal
	Thermostat OFF	Swing	LL	Horizontal	Horizontal	Horizontal	Horizontal
		Airflow direction set	LL	Horizontal	Horizontal	Horizontal	Horizontal
	Hot start from thermostat OFF mode (for prevention of cold air)	Swing	LL	Horizontal	Horizontal	Horizontal	Horizontal
		Airflow direction set	LL	Horizontal	Horizontal	Horizontal	Horizontal
	Stop	Swing	OFF	Horizontal	Horizontal	Horizontal	Totally closed
		Airflow direction set	OFF	Horizontal	Horizontal	Horizontal	Totally closed
Cooling	Thermostat ON in program dry	Swing	L (*1)	Swing	Swing	Swing	Swing
		Airflow direction set	L (*1)	Set	Set	Set	Set
	Thermostat OFF in program dry	Swing	OFF or L	Swing	Swing	Swing	Swing
		Airflow direction set		Horizontal or Set	Set	Set	Set
	Thermostat OFF in cooling	Swing	Set	Swing	Swing	Swing	Swing
		Airflow direction set	Set	Set	Set	Set	Set
	Stop	Swing	OFF	Horizontal	Horizontal	Horizontal	Totally closed
		Airflow direction set	OFF	Horizontal	Horizontal	Horizontal	Totally closed
	Microcomputer control (including cooling operation)	Swing	L	Swing	Swing	Swing	Swing
		Airflow direction set	L	Set	Set	Set	Set



**Note(s)** \*1. L or LL only on FXFQ-T and FXFQ-P models



## 6.9 Hot Start Control (In Heating Operation Only)

At startup with thermostat ON or after the completion of defrosting in heating operation, the indoor fan is controlled to prevent cold air from blasting out and ensure startup capacity.

TH2: Temperature detected with the gas thermistor

Tc : High pressure equivalent saturated temperature

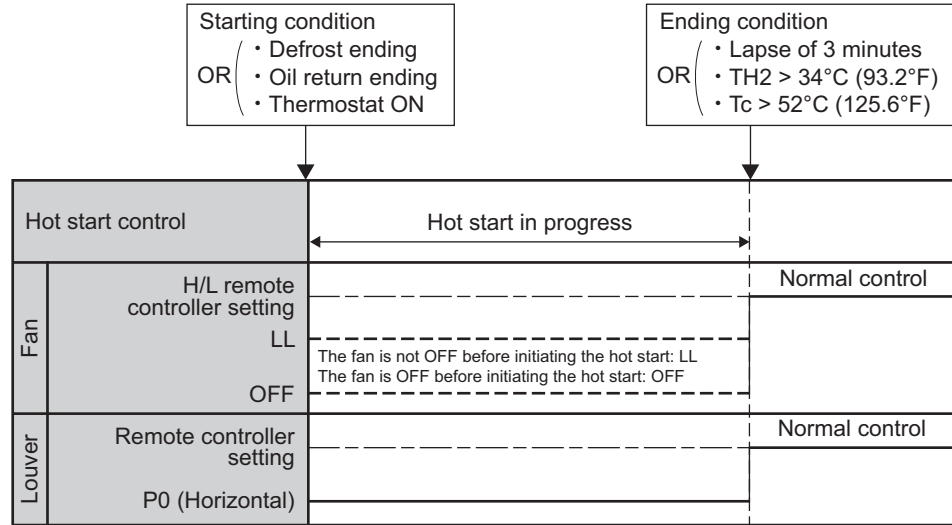

■ When the heater of FXTQ-TA is to be used

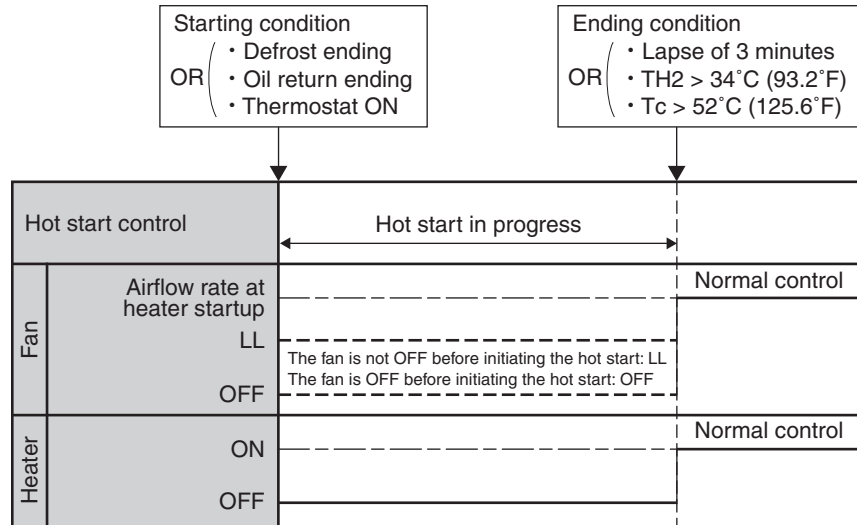

## 6.10 Louver Control for Preventing Ceiling Dirt

We have added a control feature that allows you to select the range of in which air direction can be adjusted in order to prevent the ceiling surrounding the air discharge outlet of ceiling mounted cassette type units from being soiled. (This feature is available on FXFQ-T, FXFQ-P, FXZQ-TA, FXZQ-TB, FXZQ-M and FXEQ-P models)

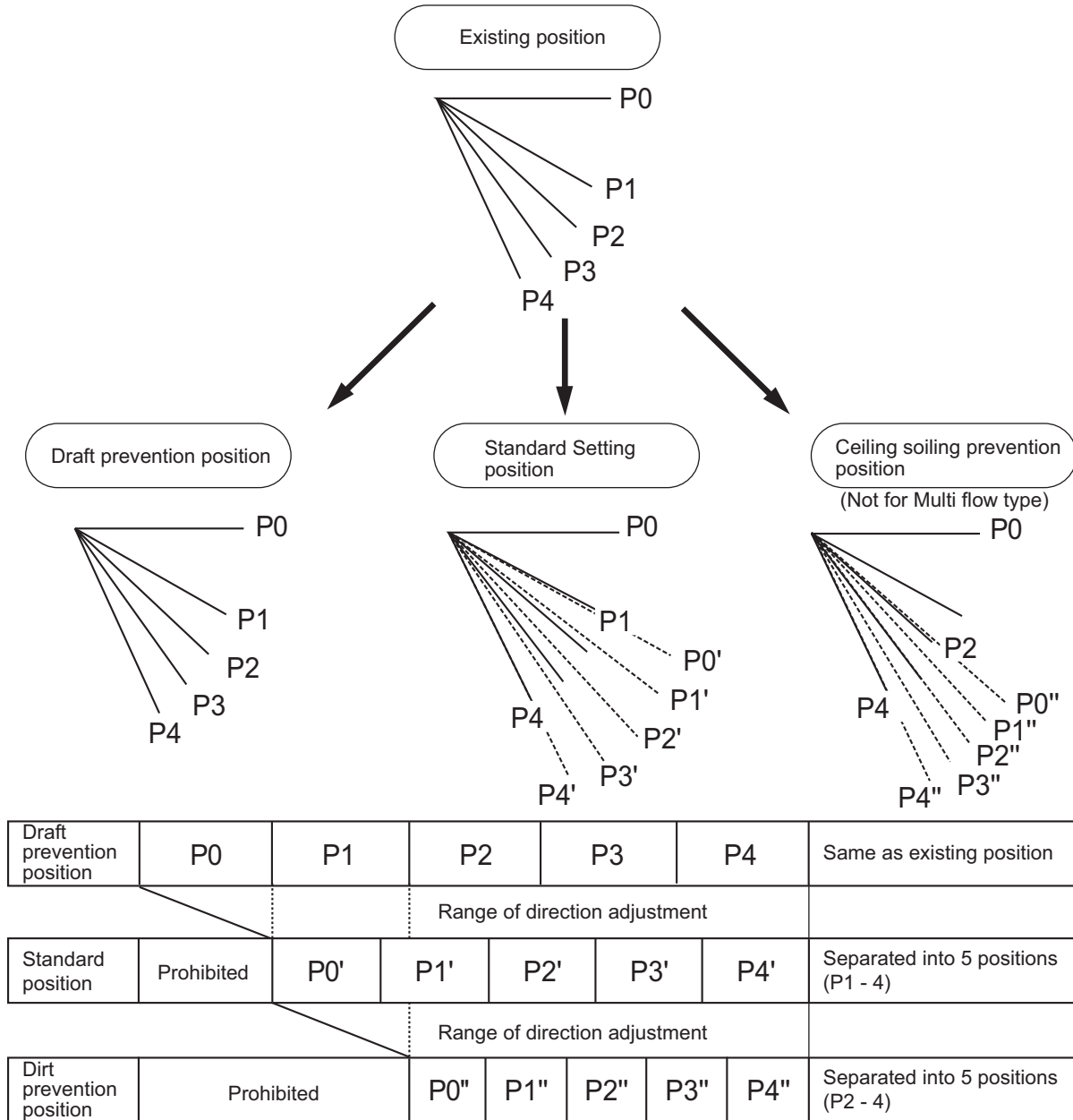

Factory setting

FXFQ-T, FXFQ-P models: draft prevention position

FXZQ-TA, FXZQ-TB, FXZQ-M, FXEQ-P models: standard position

## 6.11 Heater Control (Except FXTQ-TA Models)



**Note(s)** Optional PCB KRP1B... is required.

The heater control is conducted in the following manner.

### Normal control

While in heating, the heater control (ON/OFF) is conducted as shown below.

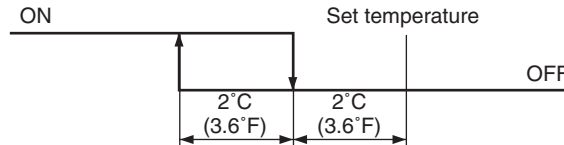

### Overload control

When the system is overloaded in heating, the heater will be turned OFF in the following 2 manners.

1. The heater control (ON/OFF) is conducted through the liquid pipe temperature (R2T) of the indoor unit.

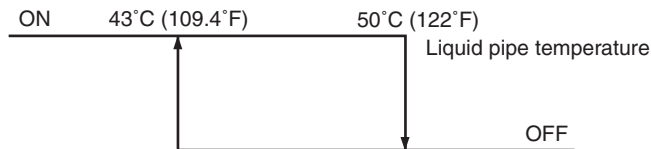

2. The heater control (ON/OFF) is conducted by converting the heater temperature into the condensing pressure equivalent saturated temperature (Tc) according to the temperature detection through the high pressure sensor (S1NPH) of the outdoor unit.

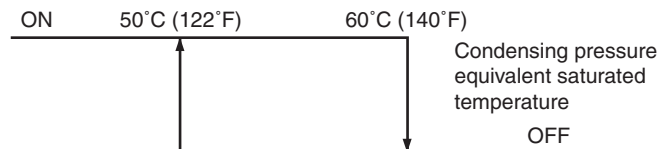

### Fan residual operation

While the heater turns OFF, in order to prevent the activation of the thermal protector, the fan conducts residual operation for a given period of time after the heater turns OFF. (This operation is conducted regardless of with or without heater equipped.)

Residual operation time: 100 seconds on ceiling suspended type or 60 seconds on other types

## 6.12 Heater Control (FXTQ-TA Models)



**Note(s)**

Optional heater kit HKS... is required.

For FXTQ-TA models, heater ON/OFF output from wiring adaptor interlocks with the operation of heater kit HKS....(When the heater 1 turns ON/OFF, heater output of wiring adaptor turns ON/OFF.) Fan residual operation also interlocks with the fan residual operation of heater kit HKS.... The residual time will be 90 seconds. (Refer to **Fan Control (Heater Residual) (FXTQ-TA Models)** on page 123.)

### 6.12.1 Auxiliary Electric Heater Control

If heating is insufficient in heat pump system alone, an electric heater is to be used as the auxiliary heater. The following shows the ON/OFF conditions for the electric heater.

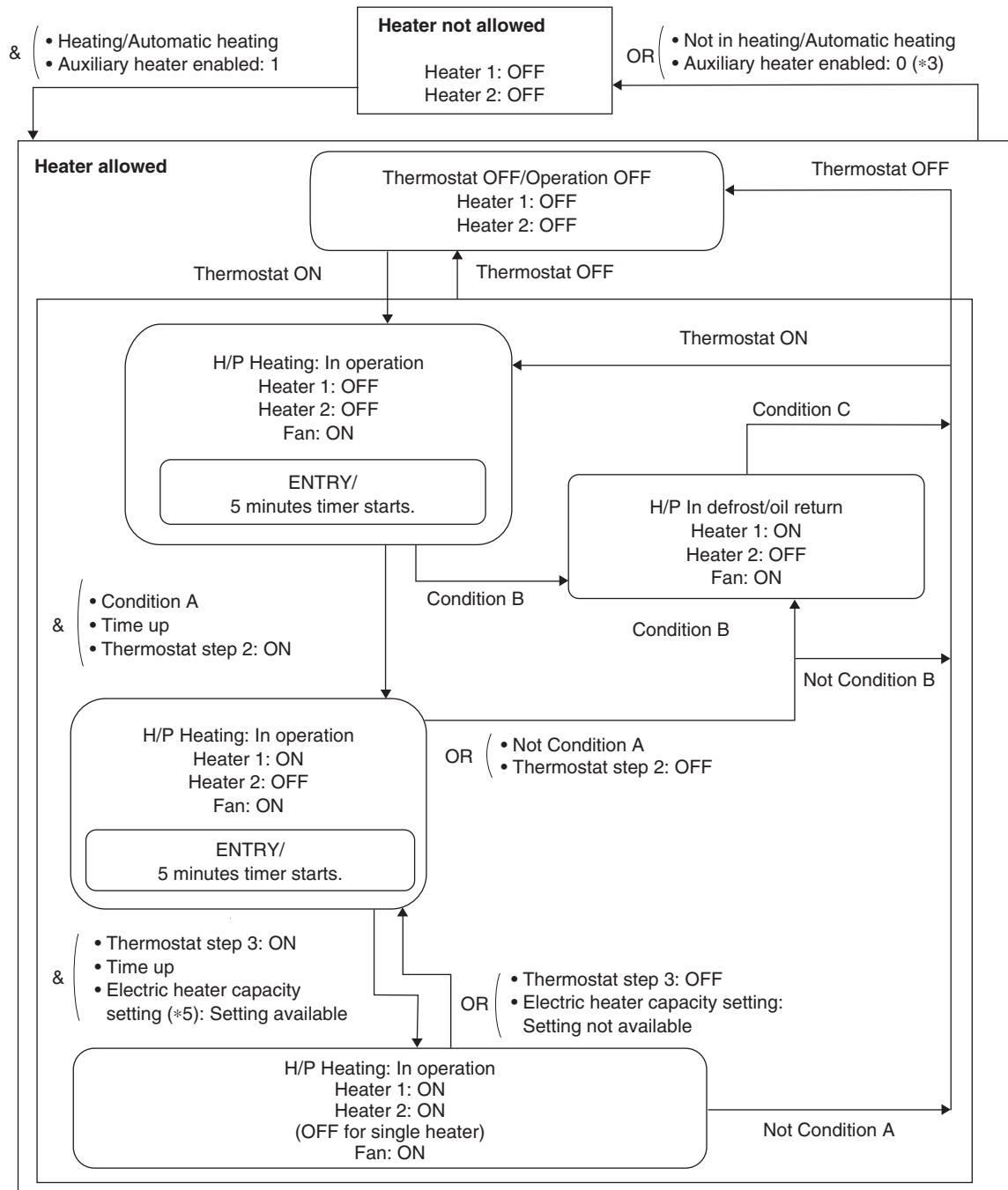

## Condition A

- No fan motor system error
  - High pressure condition: ON (\*1)
  - Liquid pipe temperature condition: ON (\*2)
- & (
- OR (
  - & (
  - Heater ON permission (Defrost/oil Return): 0 (\*4)
  - Not during defrost/oil return
  - Heater ON permission (Defrost/oil return): 1 (\*4)

## Condition B

- No fan motor system error
- During defrost/oil return
- Heater ON permission (Defrost/oil return): 1 (\*4)

## Condition C

- Not during defrost/oil return
- Fan motor system error
- Heater ON permission (Defrost/oil return): 0 (\*4)

 Note(s)

## \*1: High pressure condition

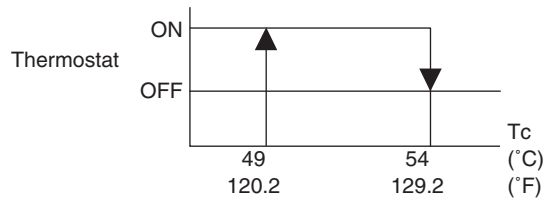

## \*2: Liquid pipe temperature condition

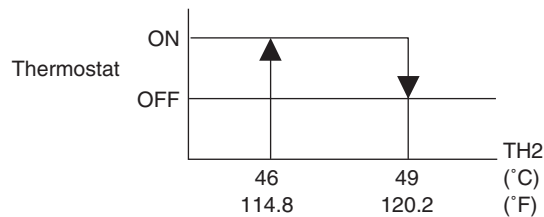

## \*3. Auxiliary heater enabled

- 1: & (
- Electric heater setting (Field setting 11 (21)-3.): **02, 08** (\*6)
- Electric heater capacity setting  $\neq$  **01**
- 0: Other than the above

## \*4. Heater ON permission (Defrost/oil return)

- 1: Electric heater setting (Field setting 11 (21)-3.): **08** (\*6)
- 0: Electric heater setting (Field setting 11 (21)-3.): **02** (\*6)

## \*5. Field setting 11(21)-5. Refer to page 141.

## \*6. Field setting 11(21)-3. Refer to page 141.

## 6.12.2 Heat Pump Lockout Control

For heating operation, users can select to use electric heater. For this, signals are sent using ABC terminal of outdoor unit PCB.

When the hot-water heating signal is received from the outdoor unit PCB, heating operation is performed only with the electric heater as manual backup operation. The ON/OFF conditions for the electric heater are shown below.

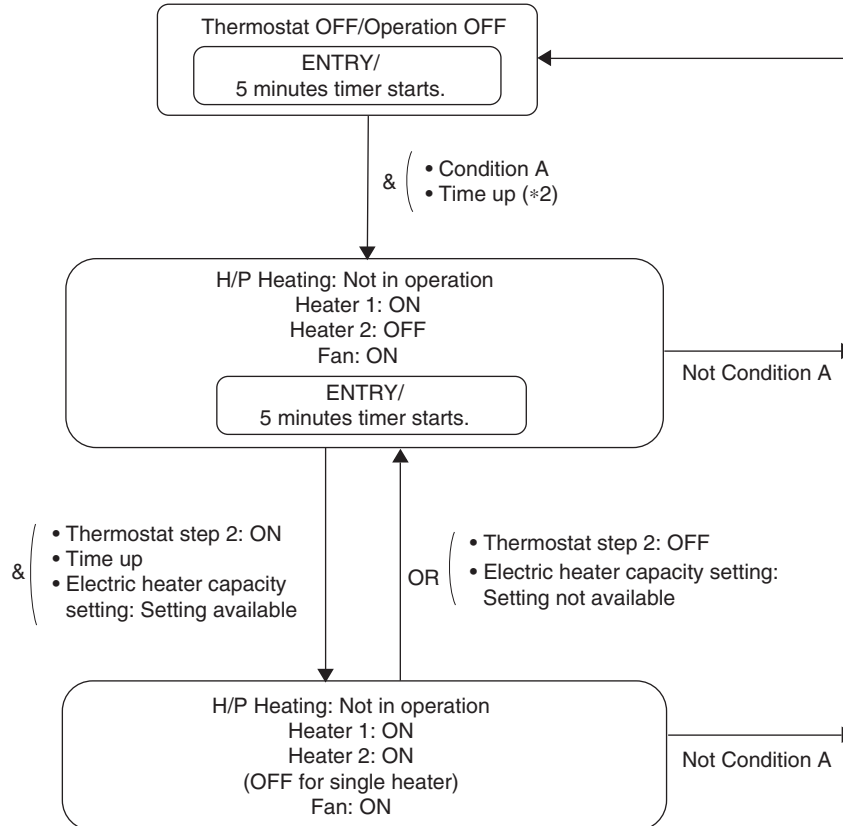

### Condition A

- Heating or automatic heating mode
- Thermostat step 1: ON
- No fan motor system error
- Hot-water heater: 1 (ON)
- Heater backup prohibiting conditions (\*1) not met (Not Condition B)

### Condition B: Heater backup prohibiting conditions (\*1)

- Indoor unit error (Abnormal stop)
- Indoor unit error (Remote controller thermistor error)
- Indoor unit error (Remote sensor error)
- Electric heater capacity setting: 01 (No heater kit)

### **i** Note(s)

- \*1. The heater backup prohibiting conditions are prioritized. Even when the heater ON conditions are met, the heater is turned OFF when the prohibiting conditions are met.
- \*2. When the remote controller is ON, Time-up will be set to the initial value.

## 6.13 Gas Furnace Control (CXTQ-TA Models)

### Outline

When conditions for gas furnace operation are established, the system transits into the standby mode for pre-gas furnace operation. In this status, heating operation is not performed with either heat pump or gas furnace. Afterward when the system transits into gas furnace operation, CXTQ-TA requires the gas furnace combustion heating.

### Detail

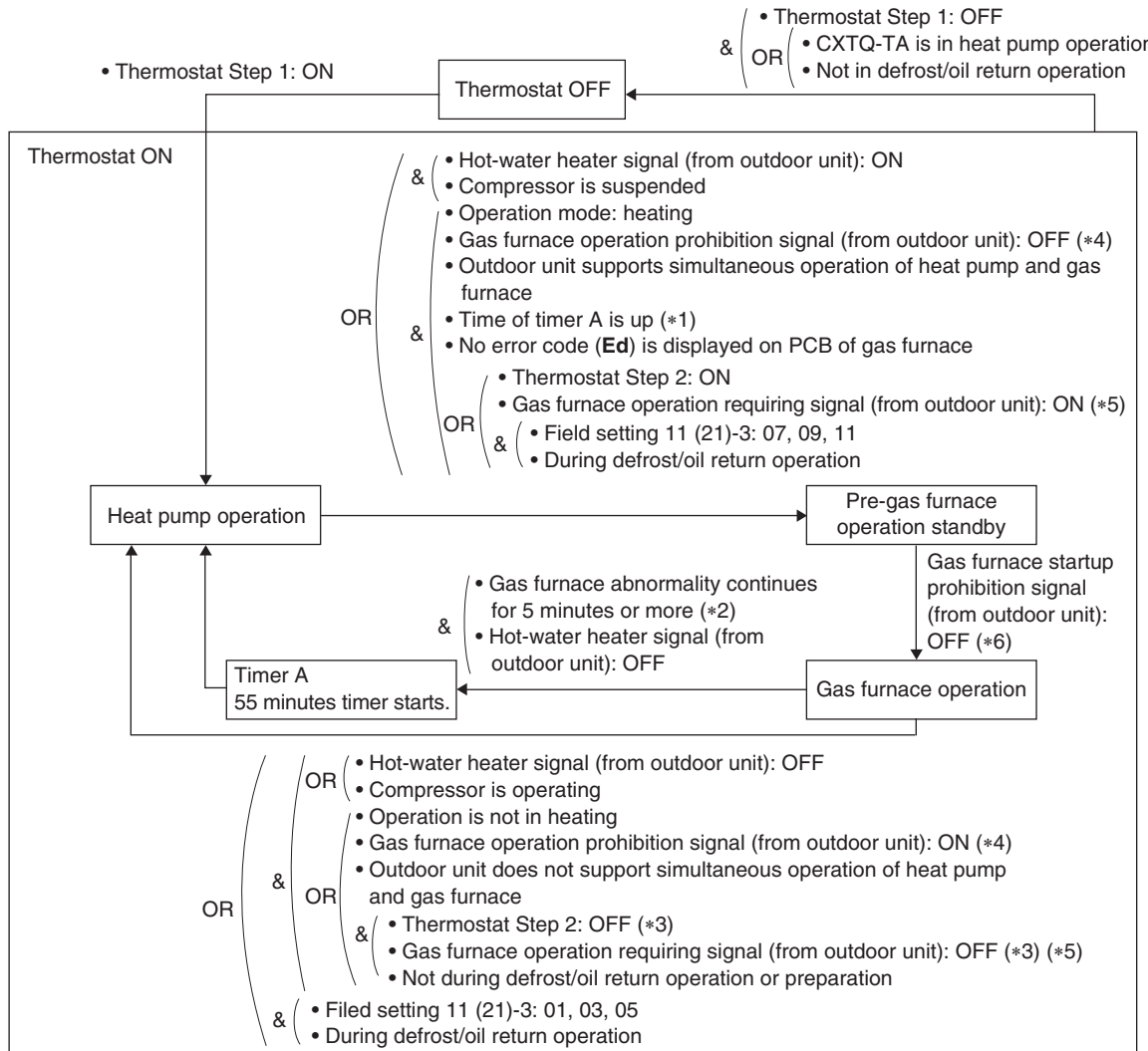

\*1. Time is up in factory setting.

\*2. **E0, E1, E2, E7, EC, Ed** are subject to the abnormality among error codes displayed on the PCB of the gas furnace.

\*3. These conditions are not established until heat pump prohibition time elapsed after entering the standby mode for pre-gas furnace operation (except for the case where the condition has been established when entering the standby mode for pre-gas furnace operation).

Refer to field setting 11 (21)-3 for the heat pump prohibition duration.

\*4. Refer to **Gas Furnace Operation Prohibition** on page 96 for details.

\*5. Refer to item 14 Switch over ambient setting on **Setting Mode 2** on page 158 for details.

\*6. Refer to **Gas Furnace Operation Startup Prohibition** on page 96 for details.



### Note(s)

The airflow rate during gas furnace operation depends on the intensity of combustion heating and therefore may be different from the airflow setting displayed on the remote controller.

## 6.14 3-Step Thermostat Processing (FXTQ-TA Models)

### Outline

The thermostat ON/OFF for the indoor unit is controlled in accordance with Thermostat step 1.  
 The heater ON/OFF operation during heating is controlled as follows.  
 Thermostat step 2, 3: Auxiliary electric heater control  
 Thermostat step 1, 2: Heat pump lockout control  
 For more details of the heater, refer to **Heater Control (FXTQ-TA Models)** on page 117.

### Detail

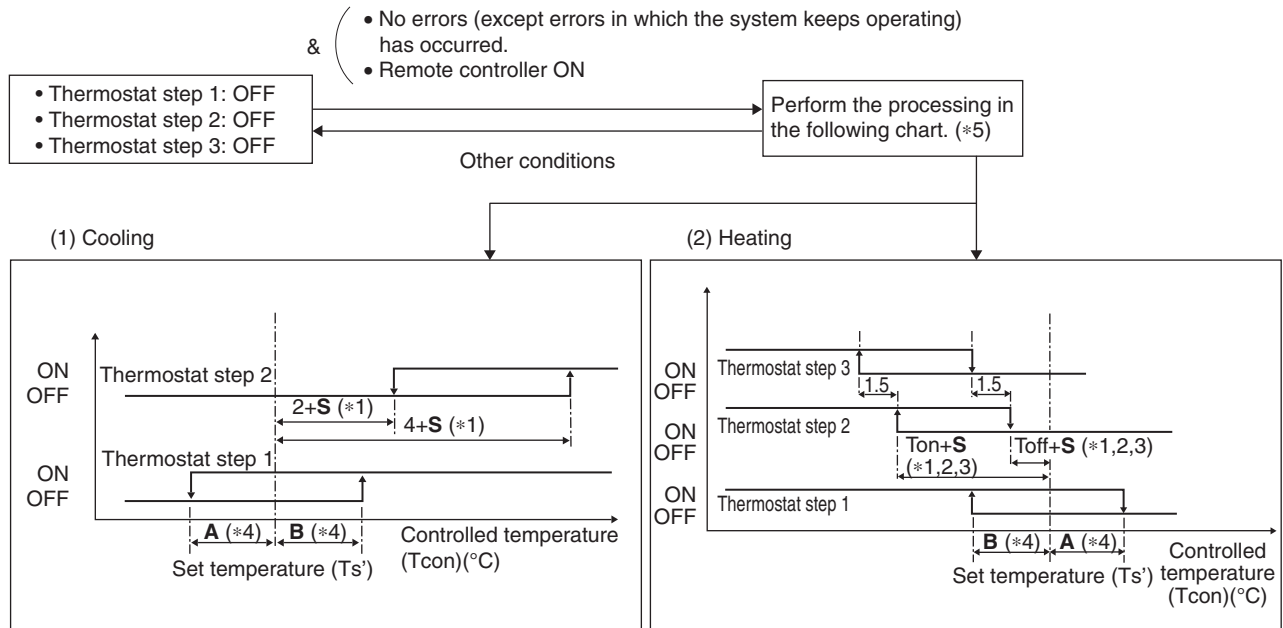

#### Note(s)

- \*1. **S** value varies automatically based on the room temperature trend.
- \*2.  $T_{on} + S > -B$  ( $^{\circ}C$ ),  $T_{off} + S < A$  ( $^{\circ}C$ )
- \*3. For parameters, refer to page 139.
- \*4. **A** and **B** values vary automatically based on the field setting 12 (22)-2.
- \*5. If, directly after a change in conditions, it is such that the thermostat could be either ON or OFF (controlled temperature is within ranges **A** and **B**), the thermostat will be switched to ON.



## 6.15 2-Step Thermostat Processing (CXTQ-TA Models)

### Outline

The thermostat ON/OFF of the indoor unit is controlled in accordance with Thermostat step 1. The gas furnace ON/OFF is controlled in accordance with Thermostat step 2.

When gas furnace operation requiring ON signal or water heater ON signal is sent from the outdoor unit, gas furnace ON/OFF is controlled in accordance with Thermostat step 1.

### Detail

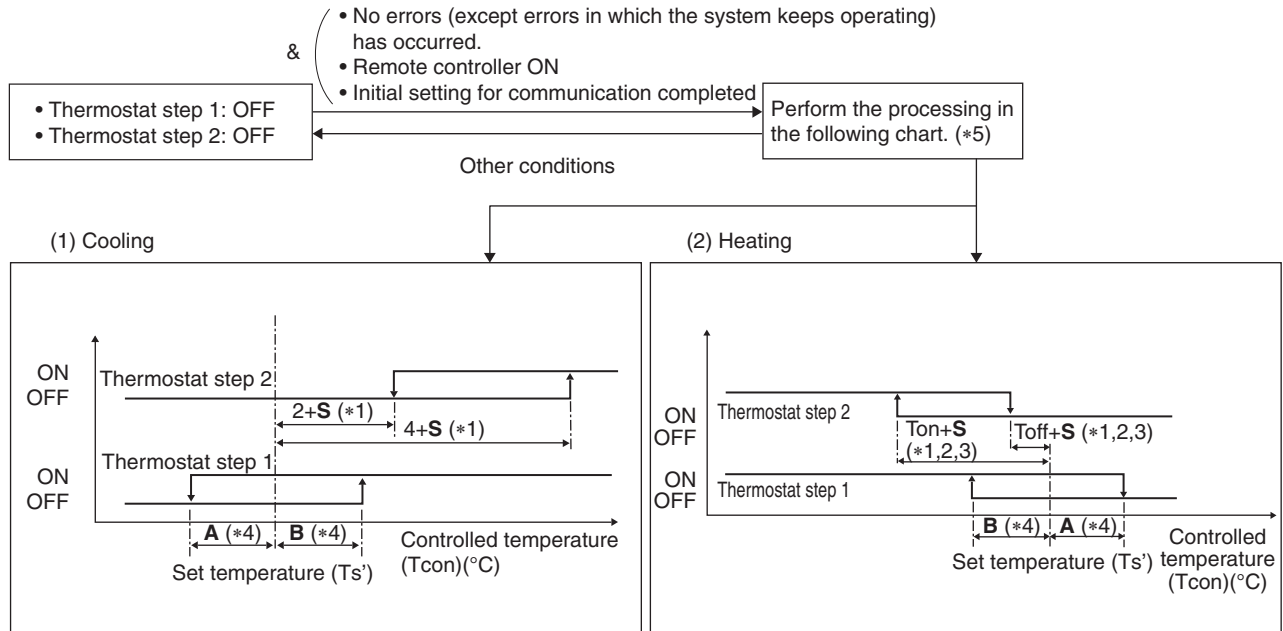

#### Note(s)

\*1. **S** value varies automatically based on the room temperature trend.

\*2.  $T_{on} + S > -B$  (°C),  $T_{off} + S < A$  (°C)

\*3. For parameters, refer to page 140.

\*4. **A** and **B** values vary automatically based on the field setting 12 (22)-2.

\*5. If, directly after a change in conditions, it is such that the thermostat could be either ON or OFF (controlled temperature is within ranges **A** and **B**), the thermostat will be switched to ON.

## 6.16 Fan Control (Heater Residual) (FXTQ-TA Models)

### Outline

If the indoor heater turned OFF from ON during heating operation, the fan will keep operating for further period of time in order to cool the heater.

### Detail

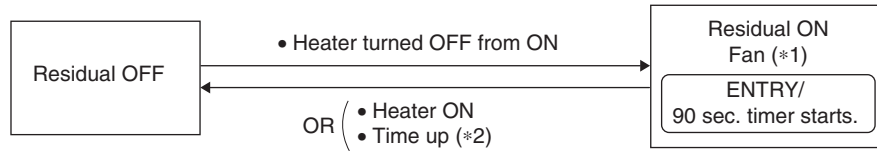

- \*1. When the heater is ON, the airflow rate of the fan will be whichever is the largest between the CFM dictated by the heater's own capacity, or the fan tap CFM determined by other controls.
- \*2. Fan residual operation will continue, even if the indoor unit is turned off with the remote controller operation button.

## 6.17 Interlocked with External Equipment (FXTQ-TA and CXTQ-TA Models)

### 6.17.1 Air Purifier (UV Lamp)

When an air purifier is connected onsite, the fan is operated with the airflow rate set of the remote controller or with the H tap.



- \*1. External input ON is an input signal to the X1M-AIR CLEANER terminal on the PCB.

### 6.17.2 Humidifier

When a humidifier is connected onsite, the fan operates with the airflow rate set of the remote controller or with the H tap.

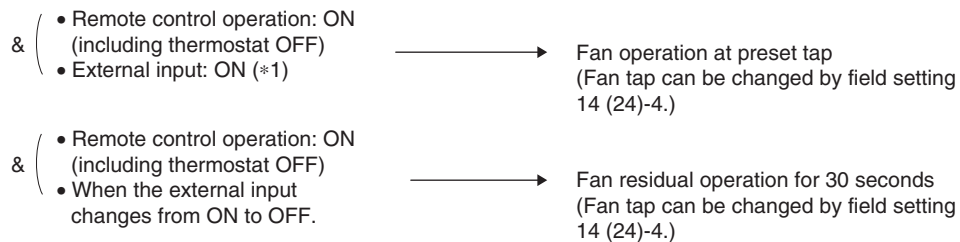

- \*1. External input ON is an input signal to the X1M-HUMIDIFIER terminal on the PCB.



#### Note(s)

This control is not applicable to the humidifier connected to the wiring adaptor, but to the humidifier connected to HUMIDIFIER on the X1M terminal of the indoor unit PCB.

## 6.17.3 Economizer

When indoor and outdoor air temperatures are reversed, the compressor is stopped to let in the outdoor air to save energy.

This operation is called economizer operation, and the equipment to detect indoor and outdoor air temperatures and open and close the damper to perform this operation is called an economizer.

The economizer detects indoor and outdoor air temperatures, informs the air conditioner that the economizer operation is ready, and opens and closes the damper.

The indoor unit stops the outdoor unit when it receives a signal from the economizer and performs air supply operation.

When the indoor air temperature is cooled down sufficiently by the economizer operation, and it is no longer necessary (thermostat OFF), the indoor unit outputs a signal to the economizer to close the damper.

### ■ Thermostat ON signal

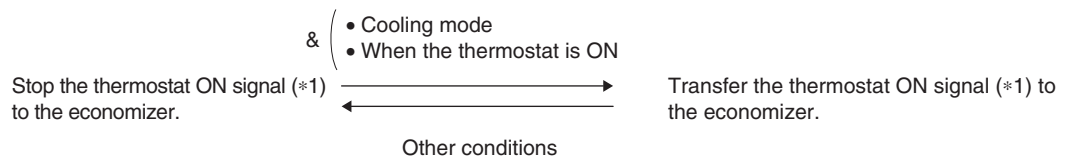

### ■ Operation

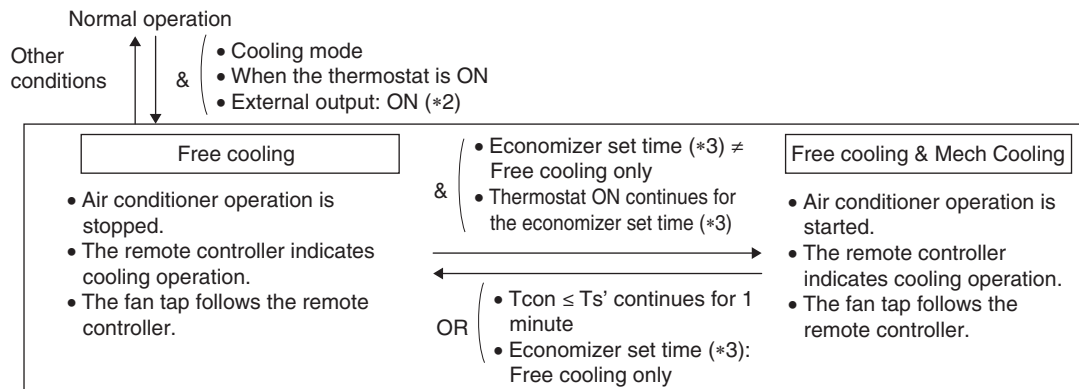

### ■ Indoor unit ON signal

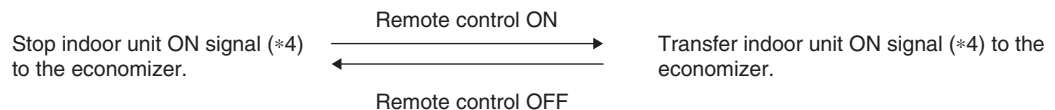

### **i** Note(s)

- \*1. Thermostat ON signal: A signal to turn ON the indoor unit thermostat and allow the economizer to open the damper.  
It turns ON the relay on the X2M-ECONOMIZER2 on the PCB.
- \*2. External input ON is an input signal to the X1M-ECONOMIZER1 terminal on the PCB.
- \*3. Refer to **Optional Kit Setting (UV lamp + Humidifier + Economizer) (for FXTQ-TA and CXTQ-TA models)** on page 149.
- \*4. Remote control ON signal: Contact output which shows the operating status of the indoor unit.  
This signal turns on the relay X2M-CONTROL ON/OFF on the PCB.

# Part 5

## Field Settings and Test Operation

1. Field Setting from Remote Controller .....	126
1.1 BRC1E73 .....	126
1.2 BRC1H71W.....	128
1.3 Wireless Remote Controller .....	131
1.4 List of Field Settings for Indoor Unit .....	132
1.5 Details of Field Settings for Indoor Unit.....	136
1.6 Gas Furnace Set Up.....	153
1.7 List of Field Settings for Outdoor-Air Processing Unit .....	154
1.8 Setting of Operation Control Mode .....	154
2. Field Settings from Outdoor Unit.....	156
2.1 Setting Mode and Monitor Mode .....	156
2.2 Setting Mode 1 .....	157
2.3 Setting Mode 2 .....	158
2.4 Monitor Mode .....	164
2.5 Setting of Low Noise Operation and Demand Operation .....	166
2.6 Setting of Refrigerant Recovery Mode .....	168
2.7 Setting of Vacuuming Mode .....	169
2.8 Final Charge Adjustment.....	169
2.9 Check Operation .....	170
2.10 Setting of Auxiliary Heater Control .....	171
2.11 Setting of Heat Pump Lockout and Emergency Heat Mode .....	172
3. Test Operation .....	174
3.1 Check Work Prior to Turning Power Supply ON .....	174
3.2 Turn Power ON .....	174
3.3 Test Operation.....	175
3.4 Gas Furnace Test Operation.....	178
3.5 Error Codes and Corresponding Measures.....	179
3.6 When Turning ON Power First Time .....	181
3.7 When Turning ON Power the Second Time and Subsequent.....	181
3.8 When an Indoor Unit or Outdoor Unit has been Added, or Indoor or Outdoor Unit PCB has been Changed .....	181

# 1. Field Setting from Remote Controller

Individual function of indoor unit can be changed from the remote controller. At the time of installation or after service inspection / repair, make the field setting in accordance with the following description. Wrong setting may cause error. (When optional accessory is mounted on the indoor unit, setting for the indoor unit may be required to change. Refer to information in the option handbook.)

## 1.1 BRC1E73

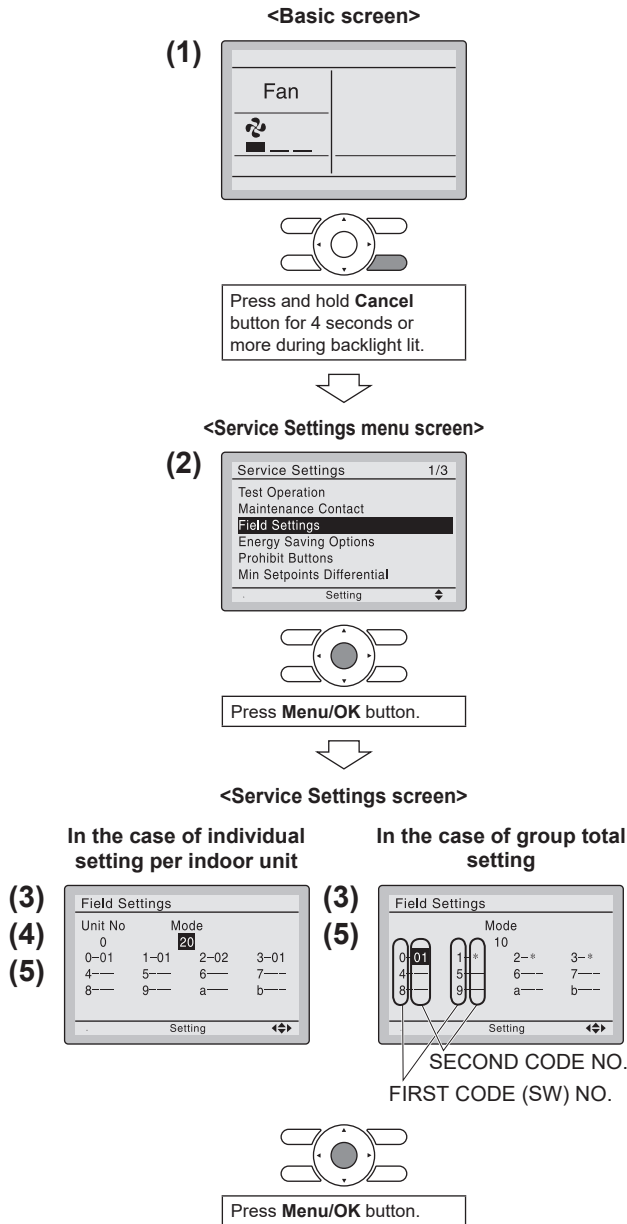

1. Press and hold **Cancel** button for 4 seconds or more. Service settings menu is displayed.
2. Select **Field Settings** in the Service Settings menu, and press **Menu/OK** button. Field settings screen is displayed.

3. Highlight the mode, and select desired **Mode No.** by using **▲▼** (Up/Down) button.
4. In the case of setting per indoor unit during group control (When Mode No. such as **20, 21, 22, 23, 25** are selected), highlight the unit No. and select **Indoor unit No.** to be set by using **▲▼** (Up/Down) button. (In the case of group total setting, this operation is not needed.)

[ In the case of individual setting per indoor unit, current settings are displayed. And, SECOND CODE NO. " - " means no function. ]

5. Highlight SECOND CODE NO. of the FIRST CODE NO. to be changed, and select desired **SECOND CODE NO.** by using **▲▼** (Up/Down) button. Multiple identical mode number settings are available.

[ In case of setting for all indoor units in the remote control group, available SECOND CODE NO. is displayed as " \* " which means it can be changed. When SECOND CODE NO. is displayed as " - ", there is no function. ]

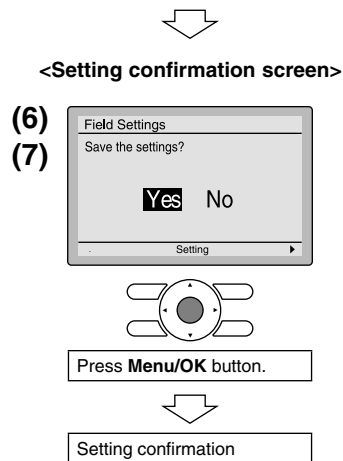

**6.** Press **Menu/OK** button. Setting confirmation screen is displayed.

**7.** Select **Yes** and press **Menu/OK** button. Setting details are determined and field settings screen returns.

**8.** In the case of multiple setting changes, repeat **(3)** to **(7)**.

**9.** After all setting changes are completed, press **Cancel** button twice.

**10.** Backlight goes out, and **Checking the connection. Please standby.** is displayed for initialization. After the initialization, the basic screen returns.

#### NOTE

- Installation of optional accessories on the indoor unit may require changes to field settings. See the manual of the optional accessory.
- For field setting details related to the indoor unit, see installation manual shipped with the indoor unit.

## 1.2 BRC1H71W

Enter the Installer Menu and make settings.

Installer menu screen

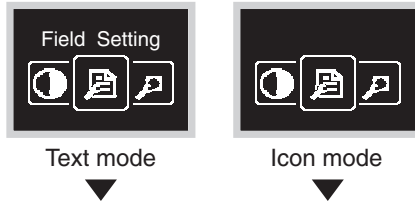

Press **←** or **→** button, for move to “”.

If Bluetooth is connected, performing field setting from the remote controller side is impossible.

Disconnect Bluetooth, or perform field setting from the mobile application.

Sub-menu screen

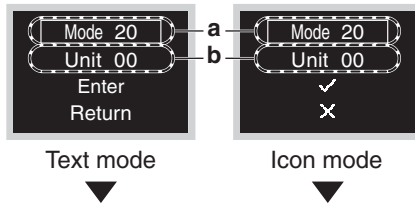

Press **+** or **←** button, to select Mode No. and press **○** to enter the field setting menu.

**a** Mode No.

**b** Unit No.

Sub-menu screen

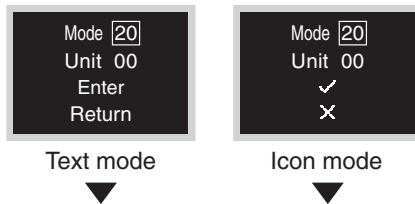

Press **←** or **→** button, to scroll the desired Mode No. and press **○** button.

Sub-menu screen

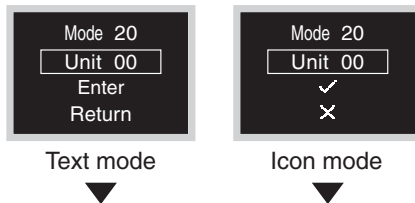

Press **←** or **→** button, to select Unit No. and press **○** button.

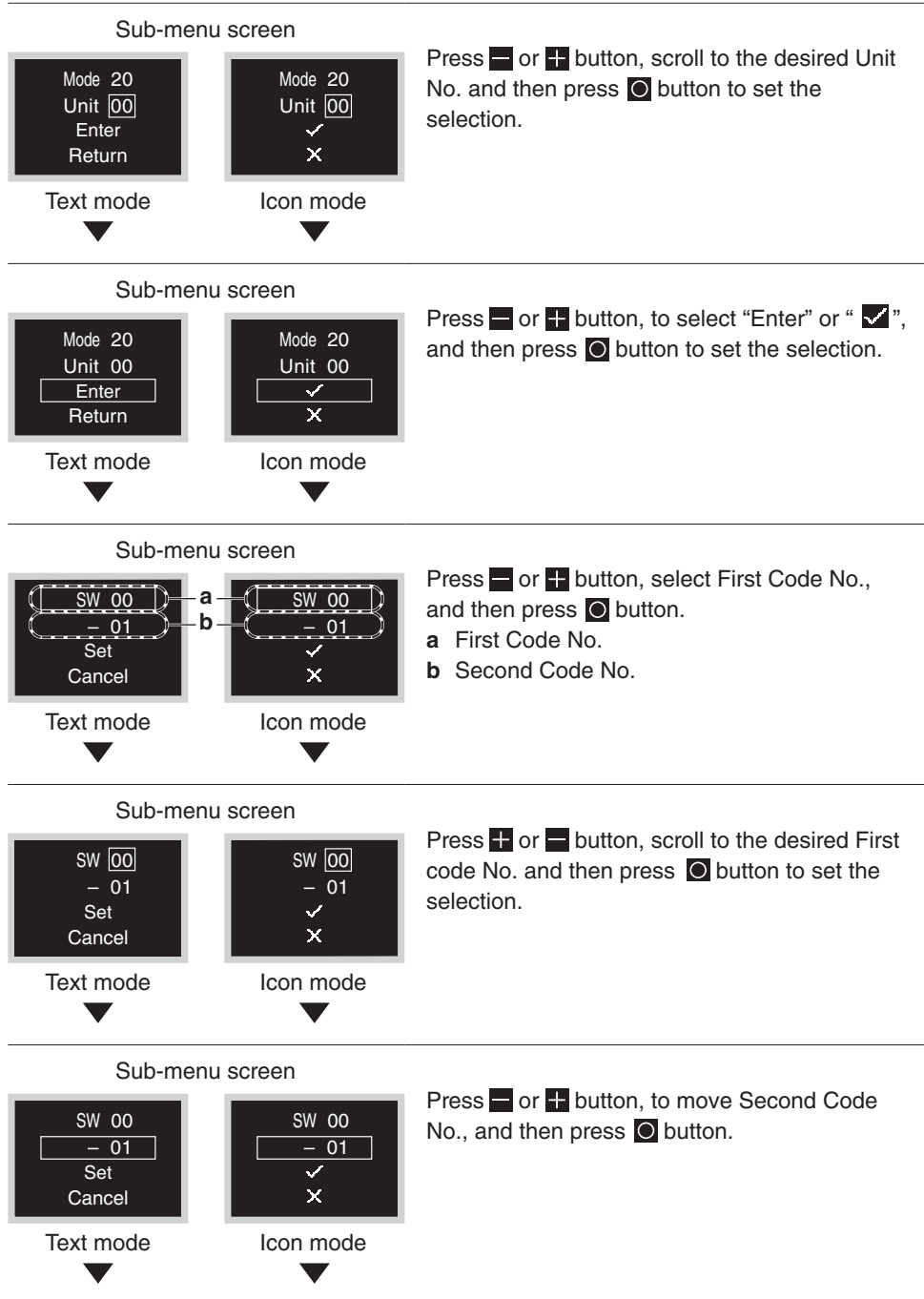



## Sub-menu screen



Text mode

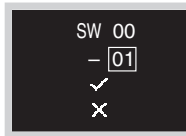

Icon mode

Press **←** or **→** button, to scroll to the desired Second Code No., and then press **○** button.

## Sub-menu screen



Text mode



Icon mode

Press **←** or **→** button, select “Set” or “**✓**”, and then press **○** button to save the setting and return to the previous screen.

If the setting is not changed, select “Cancel” or “**✕**”.

## Sub-menu screen

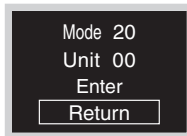

Text mode

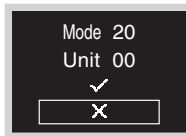

Icon mode

Press **←** or **→** button, move to “Return” or “**✕**”, and then press **○** button to return to the installer menu.

\* If the setting has been changed, the screen may return to the home screen without returning to the installer menu.

### ⚠ CAUTION

- The connection of optional accessories to the indoor unit might cause changes to some field settings. For more information, see the installation manual of the optional accessory.
- For details about the specific field settings of each type of indoor unit, see the installation manual of the indoor unit.
- Field settings that are not available for a connected indoor unit are not displayed.
- Field setting default values are different depending on the indoor unit model.

### ⚠ NOTICE

- Installation of optional accessories on the indoor unit may require changes to field settings. See the manual of the optional accessory.
- For field setting details related to the indoor unit, see installation manual shipped with the indoor unit.

## 1.3 Wireless Remote Controller

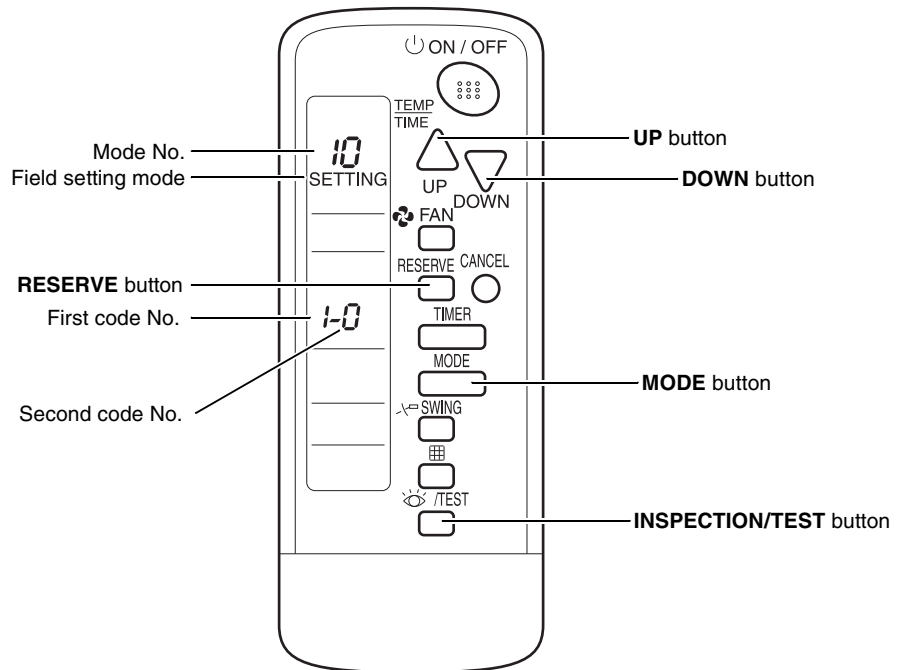

To set the field settings, you have to change:

- Mode No.
- First code No.
- Second code No.

To change the field settings, proceed as follows:

1. Press the **INSPECTION/TEST** button for 4 seconds during normal mode to enter the field setting mode.
2. Press the **MODE** button to select the desired mode No.
3. Press the **UP** button to select the first code No.
4. Press the **DOWN** button to select the second code No.
5. Press the **RESERVE** button to confirm the setting.
6. Press the **INSPECTION/TEST** button to return to the normal mode.

## 1.4 List of Field Settings for Indoor Unit

★: Factory setting

Mode No. (Note 2)	First Code No.	Setting Contents		Second Code No.				Reference Page		
				01	02	03	04			
10 (20)	0	Filter cleaning sign interval	Ultra long life filter	<b>Light</b> ★	<b>Approx. 10,000 hrs.</b> ★	Heavy	Approx. 5,000 hrs.	—	—	136
			Long life filter		<b>Approx. 2,500 hrs.</b> ★		Approx. 1,250 hrs.			
			Standard filter		<b>Approx. 200 hrs.</b> ★		Approx. 100 hrs.			
	0	Filter sign setting		<b>Light</b> ★	Heavy	—	—	—	—	136
	1	Filter type		<b>Long life filter</b> ★	Ultra long life filter	—	—	—	—	136
	1	Filter cleaning sign interval		<b>Short interval</b> ★	Long interval	—	—	—	—	136
	2	Thermistor selection		Refer to page on the right for details.				—	—	136
	3	Filter cleaning sign		<b>Displayed</b> ★	Not displayed	—	—	—	—	138
	5	Information for intelligent Touch Manager / intelligent Touch Controller		Refer to page on the right for details.				—	—	138
6	Remote controller thermistor control during group control		<b>Not permitted</b> ★	Permitted	—	—	—	—	137	
7	Time for absence area detection		<b>30 minutes</b> ★	60 minutes	—	—	—	—	138	
11 (21)	1	Auxiliary electric heater ON temperature: Ton		Refer to page on the right for details.				—	—	139
	1	Auxiliary electric heater ON/OFF temperature: Ton/Toff								
	2	Auxiliary electric heater OFF temperature: Toff								
	3	Setting of airflow rate when heating		<b>Standard</b> ★	Slightly increased	Increased	—	—	140	
	3	Electric heater setting		Refer to page on the right for details.				—	—	141
	5	Electric heater capacity setting		Refer to page on the right for details.				—	—	141
	6	Setting the rate of human detection		High sensitivity	Low sensitivity	<b>Standard sensitivity</b> ★	Infrared presence sensor disabled	—	—	142
	7	Automatic airflow adjustment		<b>OFF</b> ★	Completion of airflow adjustment	Start of airflow adjustment	—	—	142	
	8	Compensating the temperature around people		Suction air temperature only	Priorities given on the suction air temperature	<b>Standard</b> ★	Priorities given on the floor temperature	—	—	143
	9	Compensating the floor temperature		−4°C (−7.2°F)	−2°C (−3.6°F)	<b>0°C (0°F)</b> ★	+2°C (+3.6°F)	—	—	143
12	Dry mode set temperature		<b>Room temperature</b> ★	Same as cooling mode set temperature	—	—	—	—	144	
12 (22)	0	Optional output switching		Refer to page on the right for details.				—	—	144
	1	External ON/OFF input		Refer to page on the right for details.				—	—	144
	2	Thermostat switching		1°C (1.8°F)	0.5°C (0.9°F)	—	—	—	145	
	3	Airflow setting when heating thermostat is OFF		<b>LL tap</b> ★	Set fan speed	OFF	—	—	145	
	4	Setting of operation mode to AUTO		Refer to page on the right for details.				—	—	145
	5	Auto restart after power failure		OFF	<b>ON</b> ★	—	—	—	145	
	6	Airflow setting when cooling thermostat is OFF		LL tap	<b>Set fan speed</b> ★	OFF	—	—	146	

Mode No. (Note 2)	First Code No.	Setting Contents	Second Code No.				Reference Page
			01	02	03	04	
13 (23)	0	Setting of airflow rate	<b>Standard★</b>	High ceiling 1	High ceiling 2	—	146
	1	Airflow direction setting	<b>4-direction airflow★</b>	3-direction airflow	2-direction airflow	—	147
	2	Swing pattern settings	All direction synchronized swing	—	<b>Facing swing★</b>	—	147
	4	Setting of airflow direction adjustment range	Draft prevention	<b>Standard★</b>	Ceiling soiling prevention	—	147
	5	Setting of static pressure selection	<b>Standard★</b>	High static pressure	—	—	148
	6	External static pressure settings	Refer to page on the right for details.				148
14 (24)	4	Optional kit setting (UV lamp + humidifier + economizer)	Refer to page on the right for details.				149
	5	Dry mode set temperature	<b>Room temperature★</b>	Same as cooling mode set temperature	—	—	149
	9	Mold proof operation setting	—	<b>Standard★</b>	For high humidity areas	—	150
	11	Gas furnace test mode	<b>OFF★</b>	Low heat	High heat	—	150
15 (25)	0	Drain pump operation setting	—	<b>ON★</b>	OFF	—	150
	1	Humidification when heating thermostat is OFF	<b>Not equipped★</b>	Equipped	—	—	150
	2	Setting of direct duct connection	<b>Not equipped★</b>	Equipped	—	—	150
	3	Interlocked operation between humidifier and drain pump	<b>Not interlocked★</b>	Interlocked	—	—	151
	5	Individual setting of ventilation	<b>Normal★</b>	Individual	—	—	151
1b	4	Display of error codes on the remote controller	—	Two-digit display	—	<b>Four-digit display★</b>	151
1c	0	Room temperature display	Not displayed	<b>Displayed★</b>	—	—	151
	1	Thermistor sensor for auto changeover and setback control by the remote controller	Utilize the return air thermistor	<b>Utilize the remote controller thermistor★</b>	—	—	151
	3	Access permission level setting	<b>Level 2★</b>	Level 3	—	—	152
1e	2	Setback availability	<b>N/A★</b>	Heat only	Cool only	Cool/heat	152
	14	Setting "restricted / permitted" for airflow block	Refer to page on the right for details.				152

**Note(s)**

- Settings are made simultaneously for the entire group, however, if you select the mode No. inside parentheses, you can also set by each individual unit. Setting changes however cannot be checked except in the individual mode for those in parentheses.
- The mode numbers inside parentheses cannot be used by wireless remote controllers, so they cannot be set individually. Setting changes also cannot be checked.
- Do not make settings other than those described above. Nothing is displayed for functions the indoor unit is not equipped with.
- 88** or **Checking the connection. Please stand by.** may be displayed to indicate the remote controller is resetting when returning to the normal mode.

Field setting	First Code No.	Setting Modes	FXFQ-T	FXFQ-P	FXZQ-TA FXZQ-TB	FXZQ-M	FXUQ-P FXUQ-PA	FXEQ-P	FXDQ-M	FXSQ-TA FXSQ-TB
10 (20)	0	Filter cleaning sign interval	●	●	●	●	●	●	●	●
	0	Filter sign setting	—	—	—	—	—	—	—	—
	1	Filter type	●	●	●	●	●	—	—	●
	1	Filter cleaning sign interval	—	—	—	—	—	—	—	—
	2	Thermistor selection	●	●	●	●	●	●	●	●
	3	Filter cleaning sign	●	●	●	●	●	●	●	●
	5	Information for intelligent Touch Manager/intelligent Touch Controller	●	●	●	●	●	●	●	●
	6	Remote controller thermistor control during group control	●	●	●	●	●	●	●	●
11 (21)	7	Time for absence area detection	●	—	●	—	●	—	—	—
	1	Auxiliary electric heater ON temperature	—	—	●	—	●	●	—	●
	1	Auxiliary electric heater ON/OFF temperature	●	—	—	—	—	—	—	—
	2	Auxiliary electric heater OFF temperature	—	—	●	—	●	●	—	●
	3	Setting of airflow rate when heating	●	●	●	—	●	●	—	—
	3	Electric heater setting	—	—	—	—	—	—	—	—
	5	Electric heater capacity setting	—	—	—	—	—	—	—	—
	6	Setting the rate of human detection	●	—	●	—	●	—	—	—
	7	Automatic airflow adjustment	—	—	—	—	—	—	—	●
	8	Compensating the temperature around people	●	—	●	—	●	—	—	—
9	Compensating the floor temperature	●	—	—	—	●	—	—	—	
12	Dry mode set temperature	—	—	TA: — TB: ●	—	P: — PA: ●	—	—	—	TA: — TB: ●
12 (22)	0	Optional output switching	●	●	●	●	●	●	●	●
	1	External ON/OFF input	●	●	●	●	●	●	●	●
	2	Thermostat switching	●	●	●	●	●	●	●	●
	3	Airflow setting when heating thermostat is OFF	●	●	●	●	●	●	●	●
	4	Setting of operation mode to AUTO	●	●	●	●	●	●	●	●
	5	Auto restart after power failure	●	●	●	●	●	●	●	●
	6	Airflow setting when cooling thermostat is OFF	●	●	●	●	●	●	●	●
13 (23)	0	Setting of airflow rate	●	●	●	●	●	●	—	—
	1	Airflow direction setting	●	●	●	●	●	—	—	—
	2	Swing pattern settings	●	—	●	—	●	—	—	—
	4	Setting of airflow direction adjustment range	●	●	●	●	●	●	—	—
	5	Setting of static pressure selection	—	—	—	—	—	—	●	—
	6	External static pressure settings	—	—	—	—	—	—	—	●
	14 (24)	4	Optional kit setting (UV lamp + Humidifier + Economizer)	—	—	—	—	—	—	—
5		Dry mode set temperature	—	—	—	—	—	—	—	—
9		Mold proof operation setting	—	—	—	—	—	●	—	—
11		Gas furnace test mode	—	—	—	—	—	—	—	—
15 (25)	0	Drain pump operation settings	—	—	—	—	—	—	—	—
	1	Humidification when heating thermostat is OFF	●	●	●	●	●	●	●	●
	2	Setting of direct duct connection	●	●	●	—	●	●	—	—
	3	Interlocked operation between humidifier and drain pump	●	●	●	●	●	●	●	●
	5	Individual setting of ventilation	●	●	●	●	●	●	●	●
1b	4	Display of error codes on the remote controller	●	●	●	●	●	●	●	●
1c	0	Room temperature display	●	●	●	●	●	●	●	●
	1	Thermistor sensor for auto changeover and setback control by the remote controller	●	●	●	●	●	●	●	●
	3	Access permission level setting	●	●	●	●	●	●	●	●
1e	2	Setback availability	●	●	●	●	●	●	●	●
	14	Setting "restricted / permitted" for airflow block	●	—	—	—	—	—	—	—

● : Available  
 —: Not available

Field setting	First Code No.	Setting Modes	FXMQ-PB	FXMQ-TB	FXHQ-M	FXAQ-P	FXLQ-M	FXNQ-M	FXTQ-TA	CXTQ-TA
10 (20)	0	Filter cleaning sign interval	●	●	●	●	●	●	—	—
	0	Filter sign setting	—	—	—	—	—	—	●	●
	1	Filter type	—	●	—	—	—	—	—	—
	1	Filter cleaning sign interval	—	—	—	—	—	—	●	●
	2	Thermistor selection	●	●	●	●	●	●	●	●
	3	Filter cleaning sign	●	●	●	●	●	●	●	●
	5	Information for intelligent Touch Manager/intelligent Touch Controller	●	●	●	●	●	●	●	●
	6	Remote controller thermistor control during group control	●	●	●	●	●	●	●	●
7	Time for absence area detection	—	—	—	—	—	—	—	—	
11 (21)	1	Auxiliary electric heater ON temperature	—	●	—	—	●	●	●	●
	1	Auxiliary electric heater ON/OFF temperature	●	—	—	—	—	—	—	—
	2	Auxiliary electric heater OFF temperature	—	●	—	—	●	●	●	●
	3	Setting of airflow rate when heating	—	—	—	—	—	—	—	—
	3	Electric heater setting	—	—	—	—	—	—	●	—
	5	Electric heater capacity setting	—	—	—	—	—	—	●	—
	6	Setting the rate of human detection	—	—	—	—	—	—	—	—
	7	Automatic airflow adjustment	● (*1)	●	—	—	—	—	—	—
	8	Compensating the temperature around people	—	—	—	—	—	—	—	—
	9	Compensating the floor temperature	—	—	—	—	—	—	—	—
	12	Dry mode set temperature	—	●	—	—	—	—	—	—
	12 (22)	0	Optional output switching	●	●	●	●	●	●	●
1		External ON/OFF input	●	●	●	●	●	●	●	●
2		Thermostat switching	●	●	●	●	●	●	●	●
3		Airflow setting when heating thermostat is OFF	●	●	●	●	●	●	●	●
4		Setting of operation mode to AUTO	●	●	●	●	●	●	●	●
5		Auto restart after power failure	●	●	●	●	●	●	●	●
6		Airflow setting when cooling thermostat is OFF	●	●	●	●	●	●	●	●
13 (23)	0	Setting of airflow rate	—	—	●	●	—	—	—	—
	1	Airflow direction setting	—	—	—	●	—	—	—	—
	2	Swing pattern settings	—	—	—	—	—	—	—	—
	4	Setting of airflow direction adjustment range	—	—	—	●	—	—	—	—
	5	Setting of static pressure selection	—	—	—	—	—	—	—	—
	6	External static pressure settings	●	●	—	—	—	—	—	—
14 (24)	4	Optional kit setting (UV lamp + Humidifier + Economizer)	—	—	—	—	—	—	●	●
	5	Dry mode set temperature	—	—	—	—	—	—	●	●
	9	Mold proof operation setting	—	—	—	—	—	—	—	—
	11	Gas furnace test mode	—	—	—	—	—	—	—	●
15 (25)	0	Drain pump operation settings	●	—	—	—	—	—	—	—
	1	Humidification when heating thermostat is OFF	●	●	●	●	●	●	●	●
	2	Setting of direct duct connection	—	—	—	●	—	—	—	—
	3	Interlocked operation between humidifier and drain pump	●	●	●	●	●	●	—	—
	5	Individual setting of ventilation	●	●	●	●	●	●	●	●
1b	4	Display of error codes on the remote controller	●	●	●	●	●	●	●	●
1c	0	Room temperature display	●	●	●	●	●	●	●	●
	1	Thermistor sensor for auto changeover and setback control by the remote controller	●	●	●	●	●	●	●	●
	3	Access permission level setting	●	●	●	●	●	●	●	●
1e	2	Setback availability	●	●	●	●	●	●	●	●
	14	Setting "restricted / permitted" for airflow block	—	—	—	—	—	—	—	—

● : Available  
 —: Not available



**Note(s)**

\*1. FXMQ07-48PBVJU only

## 1.5 Details of Field Settings for Indoor Unit

### 1.5.1 Filter Cleaning Sign Interval, Filter Type

★: Factory setting

Setting	10 (20)-1	<b>01: Long life filter★</b>		02: Ultra long life filter	
	Filter contamination heavy/light 10 (20)-0	<b>Light 01★</b>	Heavy 02	Light 01	Heavy 02
Model	FXFQ-T	<b>2,500 hrs.★</b>	1,250 hrs.	10,000 hrs.	5,000 hrs.
	FXFQ-P				
	FXZQ-TA				
	FXZQ-TB				
	FXZQ-M				
	FXUQ-P				
	FXUQ-PA				
	FXEQ-P				
	FXSQ-TA				
	FXSQ-TB				
	FXMQ-PB				
	FXMQ-TB				
	FXHQ-M				
	FXLQ-M				
	FXNQ-M				
	FXDQ-M	<b>200 hrs.★</b>	100 hrs.	200 hrs.	100 hrs.
	FXAQ-P				

Setting	10 (20)-1	<b>01: Short interval★</b>		02: Long interval	
	Filter contamination heavy/light 10 (20)-0	<b>Light 01★</b>	Heavy 02	Light 01	Heavy 02
Model	FXTQ-TA	<b>2,500 hrs.★</b>	1,250 hrs.	10,000 hrs.	5,000 hrs.
	CXTQ-TA				

### 1.5.2 Thermistor Selection

Select a thermistor to control the room temperature.

**When the unit is not equipped with an infrared floor sensor:**

★: Factory setting

Mode No.	First Code No.	Second Code No.	Contents
10 (20)	2	<b>01★</b>	<b>Remote controller thermistor and suction air thermistor★</b>
		02	Suction air thermistor only
		03	Remote controller thermistor only

The factory setting for the Second Code No. is **01** and room temperature is controlled by the suction air thermistor and remote controller thermistor.

When the Second Code No. is set to **02**, room temperature is controlled by the suction air thermistor. When the Second Code No. is set to **03**, room temperature is controlled by the remote controller thermistor.

#### ■ FXTQ-TA, CXTQ-TA

★: Factory setting

Mode No.	First Code No.	Second Code No.	Contents
10 (20)	2	01	—
		02	Remote sensor thermistor only
		<b>03★</b>	<b>Remote controller thermistor only★</b>

When the Second Code No. is set to **02**, room temperature is controlled by the remote sensor thermistor. When the Second Code No. is set to **03**, room temperature is controlled by the remote controller thermistor.

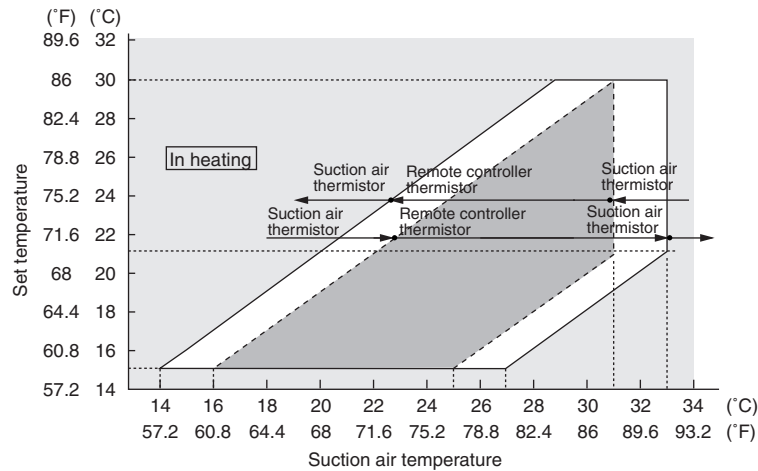
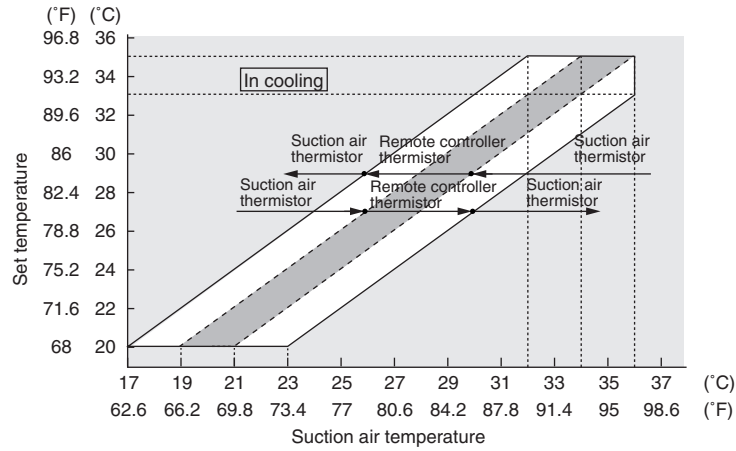

**When the unit is equipped with an infrared floor sensor:**

★ : Factory setting

Mode No.	First Code No.	Second Code No.					
		01	02	02	02★	02	03
10 (20)	2	01	02	02	02★	02	03
11 (21)	8	01	01	02	03★	04	01
The thermistor to be used		↓	↓	↓	↓	↓	↓
Remote controller thermistor		✓	—	—	—	—	✓
Suction air thermistor		✓	✓	✓	✓	✓	—
Infrared floor sensor		—	—	✓	✓	✓	—
		↓	↓	↓	↓	↓	↓
		The infrared floor sensor is not used	Priority given to the suction air temperature (*)		Priority given to the floor temperature (*)		
		↓	↓	↓	↓	↓	↓
		Only the suction air thermistor is used	Standard setting (Factory setting)		Only the remote controller thermistor is used		

\*Refer to **Compensating the Temperature around people** on page 143.

**i Note(s)**

The control is automatically switched to the one performed only by the suction air thermistor for indoor unit when the Second code No. is **01** during group control.



To use the **remote controller thermistor control during group control**, select the Second code No. **02** in First code No. **6**.

★: Factory setting

Mode No.	First Code No.	Second Code No.	Contents
10 (20)	6	<b>01★</b>	<b><u>Remote controller thermistor control is not permitted during group control</u></b> ★
		02	Remote controller thermistor control is permitted during group control.



**Note(s)**

When the 10 (20)-6 setting is changed to **02**, several indoor units are controlled by one remote controller thermistor, so note that the room temperature might be uneven.

### 1.5.3 Filter Cleaning Sign

Whether or not to display "Filter Cleaning" after operation of certain duration can be selected.

★: Factory setting

Mode No.	First Code No.	Second Code No.	Contents
10 (20)	3	<b>01★</b>	<b>Displayed</b> ★
		02	Not displayed

\* Filter cleaning sign is not displayed when an Auto-clean Panel is connected.

### 1.5.4 Information for intelligent Touch Manager/intelligent Touch Controller

★: Factory setting

Mode No.	First Code No.	Second Code No.	Contents
10 (20)	5	<b>01★</b>	<b><u>Only indoor unit sensor value (or remote controller sensor value, if installed.)</u></b> ★
		02	Sensor values according to 10 (20)-2 and 10 (20)-6.

\* When field setting 10 (20)-6-02 is set at the same time as 10 (20)-2-01,02,03, field setting 10 (20)-2 has priority.

When field setting 10 (20)-6-01 is set at the same time as 10 (20)-2-01,02,03, field setting 10 (20)-6 has priority for group connection, and 10 (20)-2 has priority for individual connection.

### 1.5.5 Time for Absence Area Detection (For units with an infrared presence sensor only)

By selecting the energy-saving operation mode in the absence, the target temperature is shifted to the energy-saving end by 1°C (1.8°F) (maximum 2°C (3.6°F)) after the state of absence continues for a certain period of time. Absent time defined for detection can be selected as follows:

★: Factory setting

Mode No.	First Code No.	Second Code No.	Contents
10 (20)	7	<b>01★</b>	<b>30 minutes</b> ★
		02	60 minutes

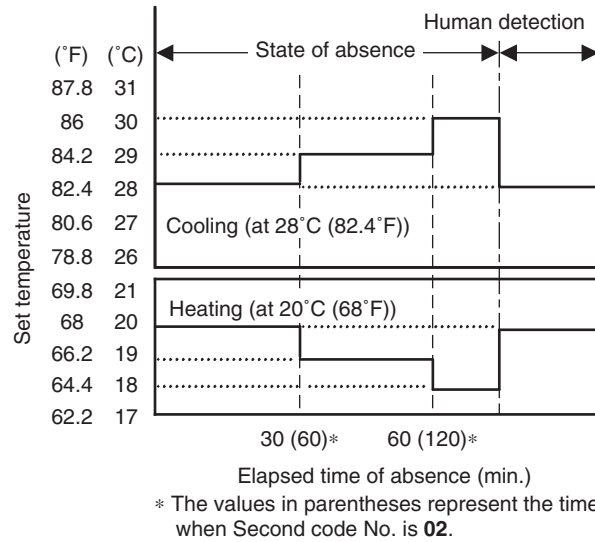

- The set temperature displayed on the remote controller remains the same even if the target temperature is shifted.
- As soon as people are detected while the temperature is shifted, this control will be cancelled (reset).

### 1.5.6 Auxiliary Electric Heater ON/OFF Temperature

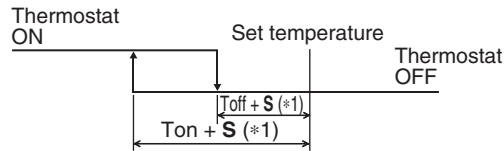

**Note(s)**

\*1. **S** value varies automatically based on the room temperature trend.

■ **FXFQ-T, FXMQ-PB**

★: Factory setting

Mode No.	First Code No.	Symbol	Second Code No.					
			01★	02	03	04	05	06
11 (21)	1	Ton	$\frac{-4^{\circ}\text{C}}{(-7.2^{\circ}\text{F})}$ ★	-3.5°C (-6.3°F)	-3°C (-5.4°F)	-2.5°C (-4.5°F)	-2°C (-3.6°F)	-1.5°C (-2.7°F)
		Toff	$\frac{-2^{\circ}\text{C}}{(-3.6^{\circ}\text{F})}$ ★	-1.5°C (-2.7°F)	-1°C (-1.8°F)	-0.5°C (-0.9°F)	0°C (0°F)	0.5°C (0.9°F)

■ **FXZQ-TA, FXZQ-TB, FXUQ-P, FXUQ-PA, FXEQ-P, FXSQ-TA, FXSQ-TB, FXMQ-TB, FXLQ-M, FXNQ-M, FXTQ-TA**

★: Factory setting

Mode No.	First Code No.	Symbol	Second Code No.					
			01★	02	03	04	05	06
11 (21)	1	Ton	$\frac{-4^{\circ}\text{C}}{(-7.2^{\circ}\text{F})}$ ★	-3.5°C (-6.3°F)	-3°C (-5.4°F)	-2.5°C (-4.5°F)	-2°C (-3.6°F)	-1.5°C (-2.7°F)
	2	Toff	$\frac{-2^{\circ}\text{C}}{(-3.6^{\circ}\text{F})}$ ★	-1.5°C (-2.7°F)	-1°C (-1.8°F)	-0.5°C (-0.9°F)	0°C (0°F)	0.5°C (0.9°F)

There is a limitation of combination between Ton and Toff as below due to 2°C (3.6°F) hysteresis required for reliability.

Second Code No.			Ton					
			01	02	03	04	05	06
			-4°C (-7.2°F)	-3.5°C (-6.3°F)	-3°C (-5.4°F)	-2.5°C (-4.5°F)	-2°C (-3.6°F)	-1.5°C (-2.7°F)
Toff	06	0.5°C (0.9°F)	●	●	●	●	●	●
	05	0°C (0°F)	●	●	●	●	●	—
	04	-0.5°C (-0.9°F)	●	●	●	●	—	—
	03	-1°C (-1.8°F)	●	●	●	—	—	—
	02	-1.5°C (-2.7°F)	●	●	—	—	—	—
	01	-2°C (-3.6°F)	●	—	—	—	—	—

- : Available  
— : Not available

■ **CXTQ-TA**

★: Factory setting

Mode No.	First Code No.	Symbol	Second Code No.						
			01	02	03	04	05	06	07 (*1)
11 (21)	1	Ton	<u>-4°C</u> <u>(-7.2°F)</u> ★	-3.5°C (-6.3°F)	-3°C (-5.4°F)	-2.5°C (-4.5°F)	-2°C (-3.6°F)	-1.5°C (-2.7°F)	-100°C (-148°F)
	2	Toff	-2°C (-3.6°F)	-1.5°C (-2.7°F)	-1°C (-1.8°F)	-0.5°C (-0.9°F)	<u>0°C</u> <u>(0°F)</u> ★	0.5°C (0.9°F)	-98°C (-144.4°F)

\*1 The second code No. 07 is used for disabling the starting of gas furnace interlocking with room temperature.

Second Code No.			Ton						
			01	02	03	04	05	06	07
			-4°C (-7.2°F)	-3.5°C (-6.3°F)	-3°C (-5.4°F)	-2.5°C (-4.5°F)	-2°C (-3.6°F)	-1.5°C (-2.7°F)	-100°C (-148°F)
Toff	07	-98°C (-144.4°F)	—	—	—	—	—	—	●
	06	0.5°C (0.9°F)	●	●	●	●	●	●	●
	05	0°C (0°F)	●	●	●	●	●	—	●
	04	-0.5°C (-0.9°F)	●	●	●	●	—	—	●
	03	-1°C (-1.8°F)	●	●	●	—	—	—	●
	02	-1.5°C (-2.7°F)	●	●	—	—	—	—	●
	01	-2°C (-3.6°F)	●	—	—	—	—	—	●

- : Available  
— : Not available

## 1.5.7 Setting of Airflow Rate when Heating

The fan revolution is changed to maintain the sufficient distance for warm air to reach during the heating operation. The setting should be changed depending on the installation condition of the unit.

★: Factory setting

Mode No.	First Code No.	Second Code No.	Contents
11 (21)	3	<u>01</u> ★	<u>Standard</u> ★
		02	Slightly increased
		03	Increased

Note that this setting is effective only during the heating operation.

### 1.5.8 Electric Heater Setting (for FXTQ-TA models)

★: Factory setting

Mode No.	First Code No.	Second Code No.	Contents	
			Heater operation	Electric heater run for defrost/oil return operation
11 (21)	3	<b>01★</b>	<b>Electric heater with heat pump not allowed★</b>	<b>Not allowed★</b>
		02	Electric heater with heat pump allowed	Not allowed
		07	Electric heater with heat pump not allowed	Allowed
		08	Electric heater with heat pump allowed	Allowed

### 1.5.9 Electric Heater Capacity Setting (for FXTQ-TA models)

★: Factory setting

Model	Mode No.	First Code No.	Second Code No.										
			<b>01★</b>	02	03	04	05	06	07	08	09	10	
			Heater (kW)										
			<b>No heater kit★</b>	3	5	6	8	10	15	19	20	25	
FXTQ09TAVJUA*	11 (21)	5	●★	●	●	—	—	—	—	—	—	—	
FXTQ09TAVJUD*			●★	●	●	—	—	—	—	—	—	—	
FXTQ12TAVJUA*			●★	●	●	●	—	—	—	—	—	—	
FXTQ12TAVJUD*			●★	●	●	●	—	—	—	—	—	—	
FXTQ18TAVJUA*			●★	●	●	●	●	●	—	—	—	—	
FXTQ18TAVJUD*			●★	●	●	●	●	●	—	—	—	—	
FXTQ24TAVJUA*			●★	●	●	●	●	●	—	—	—	—	
FXTQ24TAVJUD*			●★	●	●	●	●	●	—	—	—	—	
FXTQ30TAVJUA*			●★	●	●	●	●	●	—	—	—	—	
FXTQ30TAVJUD*			●★	●	●	●	●	●	—	—	—	—	
FXTQ36TAVJUA*			●★	●	●	●	●	●	—	—	—	—	
FXTQ36TAVJUD*			●★	●	●	●	●	●	—	—	—	—	
FXTQ42TAVJUA*			●★	—	●	●	●	●	●	●	●	—	—
FXTQ42TAVJUD*			●★	—	●	●	●	●	●	●	●	—	—
FXTQ48TAVJUA*			●★	—	●	●	●	●	●	●	●	—	—
FXTQ48TAVJUD*			●★	—	●	●	●	●	●	●	●	—	—
FXTQ54TAVJUA*			●★	—	●	●	●	●	●	●	—	●	●
FXTQ54TAVJUD*			●★	—	●	●	●	●	●	●	—	●	●
FXTQ60TAVJUA*			●★	—	●	●	●	●	●	●	—	●	●
FXTQ60TAVJUD*			●★	—	●	●	●	●	●	●	—	●	●

● : Available  
 — : Not available

### 1.5.10 Setting the Rate of Human Detection (For units with an infrared presence sensor only)

Set the sensitivity of the infrared presence sensor.

- The infrared presence sensor can be disabled by selecting the Second code No. **04**.



#### Note(s)

When the infrared presence sensor is disabled, the remote controller menu does not display some functions such as the automatic draft reduction, energy-saving operation in absence and halt in absence.

★: Factory setting

Mode No.	First Code No.	Second Code No.	Contents
11 (21)	6	01	High sensitivity
		02	Low sensitivity
		<b>03★</b>	<b>Standard sensitivity★</b>
		04	Infrared presence sensor disabled

### 1.5.11 Automatic Airflow Adjustment

Make external static pressure setting automatically using automatic airflow adjustment (11 (21)-7), or manually using external static pressure settings (13 (23)-6).

The volume of blow-off air is automatically adjusted to the rated quantity.

Make settings before performing the test operation of the outdoor unit.

#### Setting procedure

1. Make sure that electric wiring and duct construction have been completed.  
In particular, if the closing damper is installed on the way of the duct, make sure that it is open. In addition, make sure that a field-supplied air filter is installed within the air passageway on the suction port side.
2. If there are multiple blow-off and suction ports, adjust the throttle part so that the airflow volume ratio of each suction/blow-off port conforms to the designed airflow volume ratio. In that case, operate the unit with the operation mode "fan". When you want to change the airflow rate, adjust it by pressing the airflow rate control button to select High, Middle or Low.
3. Make settings to adjust the airflow rate automatically.  
After setting the operation mode to "fan", enter the field setting mode while operation is stopped and then select the Mode No. 11 (21), set the First Code No. to **7** and the Second Code No. to **03**.
4. After setting, return to the basic screen (to the normal mode in the case of a wireless remote controller) and press the ON/OFF button. Fan operation for automatic airflow adjustment will start with the operation lamp turned ON. Do not adjust the throttle part of the suction and blow-off ports during automatic adjustment. After operation for approximately one to fifteen minutes, airflow adjustment automatically stops with the operation lamp turned OFF.
5. After operation stopped, make sure that the Second Code No. is set to **02** as in the following table by indoor unit with the Mode No. 11 (21). If operation does not stop automatically or the Second Code No. is not set to **02**, return to the step 3. above to make settings again.

★: Factory setting

Mode No.	First Code No.	Second Code No.	Contents
11 (21)	7	<b>01★</b>	<b>OFF★</b>
		02	Completion of airflow adjustment
		03	Start of airflow adjustment



#### Note(s)

1. Make sure that the external static pressure is within the range of specifications before making settings. If it is outside the range, automatic adjustment fails, which may cause an insufficient airflow volume or leakage of water.

2. If the air passageway including duct or blow-off ports is changed after automatic adjustment, make sure to perform automatic airflow adjustment again.

### 1.5.12 Compensating the Temperature around People (For units with the infrared floor sensor only)

Change the ratio between the suction air temperature and floor temperature used to calculate the temperature around human.

The temperature around human is calculated using the values of the suction air thermistor and the infrared floor sensor. The factory setting is Normal (the average value of the suction air temperature and the floor temperature is applied). However, the rate at which the suction air thermistor and the infrared floor sensor affect the temperature around human can be changed with this setting.

- To reflect the effect of the temperature around the ceiling, select the "Priorities given on the suction air temperature" (the Second code No. **02**).
- To reflect the effect of the temperature around the floor, select the "Priorities given on the floor temperature" (the Second code No. **04**).
- The infrared floor sensor can be disabled by selecting "Suction air temperature only" (the Second code No. **01**).

★: Factory setting

Mode No.	First Code No.	Second Code No.	Contents
11 (21)	8	01	Suction air temperature only
		02	Priority given on the suction air temperature
		<b>03★</b>	<b>Standard★</b>
		04	Priority given on the floor temperature

### 1.5.13 Compensating the Floor Temperature (For units with an infrared floor sensor only)

Offset the detected value of the infrared floor sensor with a certain temperature. This setting should be used to have the actual floor temperature detected when, for example, the unit is installed close to a wall.

★: Factory setting

Mode No.	First Code No.	Second Code No.	Contents
11 (21)	9	01	-4°C (-7.2°F)
		02	-2°C (-3.6°F)
		<b>03★</b>	<b>0°C (0°F) ★</b>
		04	+2°C (+3.6°F)

Actual procedure to use the setting

Although the standard setting is normally used with no problem, the setting should be changed in the following cases:

Environment	Operation Mode	Problem	Setting Value
- The unit is installed close to a wall or a window. - High thermal capacity of the floor (such as concrete, etc.) - There are many heat sources including PC. - There is a non-negligible heat source such as floor heating.	Heating	Excessive heating	+2°C (+3.6°F)
		Insufficient heating	-2°C or -4°C (-3.6°F or -7.2°F)

### 1.5.14 Dry Mode Set Temperature (for FXZQ-TB, FXUQ-PA, FXSQ-TB, and FXMQ-TB models)

★: Factory setting

Mode No.	First Code No.	Second Code No.	Contents
11 (21)	12	<b>01★</b>	<b>Room temperature★</b>
		02	Same as cooling mode set temperature

### 1.5.15 Optional Output Switching

Using this setting, "operation output signal" and "abnormal output signal" can be provided. Output signal is output between terminals X1 and X2 of "adaptor for wiring", an optional accessory.

★: Factory setting

Mode No.	First Code No.	Second Code No.	Contents
12 (22)	0	<b>01★</b>	<b>Indoor unit thermostat ON/OFF signal is provided. ★</b>
		02	—
		03	Output linked with "Start/Stop" of remote controller is provided.
		04	In case of "Error Display" appears on the remote controller, output is provided.
		05	—
		06	—
		07	Only for FXSQ-TA, FXSQ-TB, FXMQ-PB, FXMQ-TB Economizer (field supply) ON/OFF signal is provided.

### 1.5.16 External ON/OFF Input

This input is used for "ON/OFF operation" and "Protection device input" from the outside. The input is performed from the T1-T2 terminal of the operation terminal block in the electrical component box.

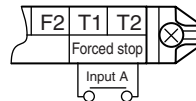

★: Factory setting

Mode No.	First Code No.	Second Code No.	Contents
12 (22)	1	<b>01★</b>	<b>ON: Forced stop (prohibition of using the remote controller) ★</b> <b>OFF: Permission of using the remote controller★</b>
		02	OFF → ON: Permission of operation ON → OFF: Stop
		03	ON: Operation OFF: The system stops, then the applicable unit indicates <b>A0</b> . The other indoor units indicate <b>U9</b> .
		04	—
		05	Only for FXSQ-TA, FXMQ-PB ON: Economizer (field supply) is connected. OFF: Not connected
		06	—
		07	Only for FXSQ-TB, FXMQ-TB ON: Economizer (field supply) is connected. OFF: Not connected

## 1.5.17 Thermostat Switching

Differential value during thermostat ON/OFF control can be changed.

Mode No.	First Code No.	Second Code No.	Contents
12 (22)	2	01	1°C (1.8°F)
		02	0.5°C (0.9°F)

### Factory Setting

Model	Second Code No.	Contents
FXFQ-T, FXFQ-P, FXZQ-TA, FXZQ-M, FXUQ-P, FXEQ-P, FXSQ-TA, FXHQ-M, FXTQ-TA	01	1°C (1.8°F)
FXZQ-TB, FXUQ-PA, FXDQ-M, FXSQ-TB, FXMQ-PB, FXMQ-TB, FXAQ-P, FXLQ-M, FXNQ-M, FXMQ-MF, CXTQ-TA	02	0.5°C (0.9°F)

## 1.5.18 Airflow Setting when Heating Thermostat is OFF

This setting is used to set airflow when heating thermostat is OFF.

If the airflow setting when thermostat is OFF is set to 03: OFF, the air in the indoor unit will be stagnant and suction air thermistor may not detect room temperature correctly, resulting in problems that thermostat will not be ON easily.

Use optional remote sensor in such conditions, or set the field setting 10 (20)-2 to **03** (only remote controller thermistor).

\* When thermostat OFF airflow volume up mode is used, careful consideration is required before deciding installation location.

★: Factory setting

Mode No.	First Code No.	Second Code No.	Contents
12 (22)	3	<b>01★</b>	<b>LL tap★</b>
		02	Set fan speed
		03	OFF

## 1.5.19 Setting of Operation Mode to AUTO

This setting makes it possible to change differential values for mode selection while in automatic operation mode, only when the wireless remote controller or any central remote controller is connected.

★: Factory setting

Mode No.	First Code No.	Second Code No.							
		<b>01★</b>	02	03	04	05	06	07	08
12 (22)	4	<b>0°C (0°F)★</b>	1°C (1.8°F)	2°C (3.6°F)	3°C (5.4°F)	4°C (7.2°F)	5°C (9.0°F)	6°C (10.8°F)	7°C (12.6°F)

The automatic operation mode setting is made by the use of the "Operation Mode Selector" button.

## 1.5.20 Auto Restart after Power Failure

★: Factory setting

Mode No.	First Code No.	Second Code No.	Contents
12 (22)	5	01	OFF
		<b>02★</b>	<b>ON★</b>

When the "Auto Restart after Power Failure" setting is turned OFF, all the units will remain OFF after power failure, or after the main power supply is restored. When this setting is turned ON (factory setting), the units that were operating before the power failure will automatically restart operation after power failure, or after the main power supply is restored.



Due to the aforementioned, when the "Auto restart after power failure" setting is ON, be careful for the following situations that may occur.



### Caution

1. The air conditioner will start operation suddenly after power failure, or when the main power supply is restored. The user might be surprised and wonder why the air conditioner turned ON suddenly.
2. During maintenance, if the main power supply is turned OFF while the units are in operation, the units will automatically start operation (the fan will rotate) after the power supply is restored due to completion of the maintenance work.

## 1.5.21 Airflow Setting when Cooling Thermostat is OFF

This is used to set airflow to LL airflow when cooling thermostat is OFF.

If the airflow setting when thermostat is OFF is set to 03: OFF, the air in the indoor unit will be stagnant and suction air thermistor may not detect room temperature correctly, resulting in problems that thermostat will not be ON easily.

Use optional remote sensor in such conditions, or set the field setting 10 (20)-2 to **03** (only remote controller thermistor).

★: Factory setting

Mode No.	First Code No.	Second Code No.	Contents
12 (22)	6	01	LL tap
		<b>02★</b>	<b>Set fan speed★</b>
		03	OFF

## 1.5.22 Setting of Airflow Rate

Make the following setting according to the ceiling height. The second code No. is set to **01** at the factory.

### ■ FXFQ07-24T, FXFQ09-30P, FXUQ18/24P, FXUQ18/24PA

★: Factory setting

Mode No.	First Code No.	Second Code No.	Contents	Ceiling height		
				4-way Outlets	3-way Outlets	2-way Outlets
13 (23)	0	<b>01★</b>	<b>Standard★</b>	<b>Lower than 2.7 m (8-3/4 ft) ★</b>	<b>Lower than 3.0 m (10 ft) ★</b>	<b>Lower than 3.5 m (11-1/2 ft) ★</b>
		02	High Ceiling 1	Lower than 3.0 m (10 ft)	Lower than 3.3 m (10-3/4 ft)	Lower than 3.8 m (12-1/2 ft)
		03	Higher Ceiling 2	Lower than 3.5 m (11-1/2 ft)	Lower than 3.5 m (11-1/2 ft)	—

### ■ FXFQ30-48T, FXFQ36/48P, FXUQ30/36P, FXUQ30/36PA

★: Factory setting

Mode No.	First Code No.	Second Code No.	Contents	Ceiling height		
				4-way Outlets	3-way Outlets	2-way Outlets
13 (23)	0	<b>01★</b>	<b>Standard★</b>	<b>Lower than 3.2 m (10-1/2 ft) ★</b>	<b>Lower than 3.6 m (12 ft) ★</b>	<b>Lower than 4.2 m (13-3/4 ft) ★</b>
		02	High Ceiling 1	Lower than 3.6 m (12 ft)	Lower than 4.0 m (13-1/8 ft)	Lower than 4.2 m (13-3/4 ft)
		03	Higher Ceiling 2	Lower than 4.2 m (13-3/4 ft) (*1)	Lower than 4.2 m (13-3/4 ft) (*1)	—

\*1. For FXUQ30/36PA, applicable lower than 4.0 m (13 ft).

■ FXZQ-TA, FXZQ-TB, FXZQ-M, FXEQ-P

★: Factory setting

Mode No.	First Code No.	Second Code No.	Contents	Ceiling height
13 (23)	0	<b>01★</b>	<b>Standard★</b>	<b>Lower than 2.7 m (8-3/4 ft) ★</b>
		02	High Ceiling 1	Lower than 3.0 m (10 ft)
		03	Higher Ceiling 2	Lower than 3.5 m (11-1/2 ft)

■ FXHQ-M, FXAQ-P

★: Factory setting

Mode No.	First Code No.	Second Code No.	Ceiling height
13 (23)	0	<b>01★</b>	<b>Standard★</b>
		02	Slight increase
		03	Normal increase

### 1.5.23 Airflow Direction Setting

Set the airflow direction of indoor units as given in the table below. (Set when sealing material kit of air discharge outlet has been installed.) The second code No. is factory set to **01**.

★: Factory setting

Mode No.	First Code No.	Second Code No.	Ceiling height
13 (23)	1	<b>01★</b>	<b>F: 4-direction airflow★</b>
		02	T: 3-direction airflow
		03	W: 2-direction airflow

### 1.5.24 Swing Pattern Settings (For units with the infrared floor sensor only)

Set the flap operation in swing mode.

With the factory swing, flaps facing each other are synchronized to operate, and flaps placed side by side are set to swing in an opposite direction to agitate airflow to reduce temperature irregularity. Conventional swing operation (all direction synchronized swing) can be set onsite.

★: Factory setting

Mode No.	First Code No.	Second Code No.	Contents
13 (23)	2	01	All direction synchronized swing
		02	—
		<b>03★</b>	<b>Facing swing★</b>

### 1.5.25 Setting of Airflow Direction Adjustment Range

Make the following airflow direction setting according to the respective purpose.

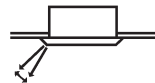

★: Factory setting

Mode No.	First Code No.	Second Code No.	Contents
13 (23)	4	01	Upward (Draft prevention)
		<b>02★</b>	<b>Standard★</b>
		03	Downward (Ceiling soiling prevention)

\* Some indoor unit models are not equipped with draft prevention (upward) function.

## 1.5.26 Setting of Static Pressure Selection (for FXDQ-M models)

★: Factory setting

Mode No.	First Code No.	Second Code No.	Contents
13 (23)	5	<b>01★</b>	<b>Standard (FXDQ07-12M: 10 Pa (0.04 inWG), FXDQ18/24M: 30 Pa (0.12 inWG)) ★</b>
		02	High static pressure (FXDQ07-12M: 15 Pa (0.06 inWG), FXDQ18/24M: 45 Pa (0.18 inWG))

## 1.5.27 External Static Pressure Settings

Make external static pressure setting automatically using automatic airflow adjustment (11 (21)-7), or manually using external static pressure settings (13 (23)-6).

### ■ FXMQ-PB models

★: Factory setting

Mode No.	First Code No.	Second Code No.	Contents
13 (23)	6	01	30 Pa (0.12 inWG) (*1) (*3)
		<b>02★</b>	<b>50 Pa (0.20 inWG) ★</b>
		03	60 Pa (0.24 inWG)
		04	70 Pa (0.28 inWG)
		05	80 Pa (0.32 inWG)
		06	90 Pa (0.36 inWG)
		<b>07★</b>	<b>100 Pa (0.40 inWG) ★</b>
		08	110 Pa (0.44 inWG) (*2)
		09	120 Pa (0.48 inWG) (*2)
		10	130 Pa (0.52 inWG) (*2)
		11	140 Pa (0.56 inWG) (*2)
		12	150 Pa (0.60 inWG) (*2) (*3)
		13	160 Pa (0.64 inWG) (*2) (*3)
		14	180 Pa (0.72 inWG) (*2) (*3)
		15	200 Pa (0.80 inWG) (*2) (*3)

The Second Code No. is set to **02** for FXMQ07/09/12PB, and **07** for FXMQ15/18/24/30/36/48/54PB at factory setting.

\*1. FXMQ15/18/24/30/36/48PB cannot be set to 30 Pa (0.12 inWG).

\*2. FXMQ07/09/12PB cannot be set to 110-200 Pa (0.44-0.80 inWG).

\*3. FXMQ54PB cannot be set to 30 Pa (0.12 inWG) or 150-200 Pa (0.60-0.80 inWG).

### ■ FXSQ-TA, FXSQ-TB models

★: Factory setting

Mode No.	First Code No.	Second Code No.	Contents
13 (23)	6	03	30 Pa (0.12 inWG) (*1) (*2)
		04	40 Pa (0.16 inWG) (*1) (*2)
		<b>05★</b>	<b>50 Pa (0.20 inWG) ★</b>
		06	60 Pa (0.24 inWG)
		07	70 Pa (0.28 inWG)
		08	80 Pa (0.32 inWG)
		09	90 Pa (0.36 inWG)
		10	100 Pa (0.40 inWG)
		11	110 Pa (0.44 inWG)
		12	120 Pa (0.48 inWG)
		13	130 Pa (0.52 inWG)
		14	140 Pa (0.56 inWG)
		15	150 Pa (0.60 inWG) (*2)

\*1. FXSQ18-48TA, FXSQ18-48TB cannot be set to 30-40 Pa (0.12-0.16 inWG).

\*2. FXSQ54TA, FXSQ54TB cannot be set to 30-40 Pa (0.12-0.16 inWG) or 150 Pa (0.60 inWG).

## ■ FXMQ-TB models

★: Factory setting

Mode No.	First Code No.	Second Code No.	Contents
13 (23)	6	02	50 Pa (0.20 inWG)
		03	60 Pa (0.24 inWG)
		04	70 Pa (0.28 inWG)
		05	80 Pa (0.32 inWG)
		06	90 Pa (0.36 inWG)
		<b>07★</b>	<b>100 Pa (0.40 inWG) ★</b>
		08	110 Pa (0.44 inWG)
		09	120 Pa (0.48 inWG)
		10	130 Pa (0.52 inWG)
		11	140 Pa (0.56 inWG)
		12	150 Pa (0.60 inWG) (*1)
		13	160 Pa (0.64 inWG) (*1)
		14	180 Pa (0.72 inWG) (*1)
		15	200 Pa (0.80 inWG) (*1)

\*1. FXMQ54TB cannot be set to 150-200 Pa (0.60-0.80 inWG).

### 1.5.28 Optional Kit Setting (UV lamp + Humidifier + Economizer) (for FXTQ-TA and CXTQ-TA models)

★: Factory setting

Mode No.	First Code No.	Second Code No.	Contents	
			UV lamp + humidifier fan speed	Economizer setting for Mech standby duration (minutes)
14 (24)	4	01	Refer to controller	10
		02	High	10
		03	Refer to controller	20
		04	High	20
		05	Refer to controller	30
		06	High	30
		07	Refer to controller	40
		08	High	40
		09	Refer to controller	50
		10	High	50
		11	Refer to controller	60
		12	High	60
		13	Refer to controller	Free cooling only
		<b>14★</b>	<b>High★</b>	<b>Free cooling only★</b>

### 1.5.29 Dry Mode Set Temperature (for FXTQ-TA and CXTQ-TA models)

★: Factory setting

Mode No.	First Code No.	Second Code No.	Contents
14 (24)	5	<b>01★</b>	<b>Room temperature★</b>
		02	Same as cooling mode set temperature

### 1.5.30 Mold Proof Operation Setting (for FXEQ-P models)

★: Factory setting

Mode No.	First Code No.	Second Code No.	Contents
14 (24)	9	01	—
		<b>02★</b>	<b>Standard★</b>
		03	For high humidity areas (*)

\* Areas with average humidity over 80%.

### 1.5.31 Gas Furnace Test Mode (for CXTQ-TA models)

This setting is used for gas furnace test run.

For details, refer to **Gas Furnace Test Operation** on page 178.

★: Factory setting

Mode No.	First Code No.	Second Code No.	Contents
14 (24)	11	<b>01★</b>	<b>OFF★</b>
		02	Low heat
		03	High heat

### 1.5.32 Drain Pump Operation Settings (for FXMQ-PB models)

The drain pump operation can be disabled for natural drainage by changing the following field setting.

★: Factory setting

Mode No.	First Code No.	Second Code No.	Contents
15 (25)	0	01	—
		<b>02★</b>	<b>ON★</b>
		03	OFF

### 1.5.33 Humidification when Heating Thermostat is OFF

Setting to "Humidification Setting" turns ON the humidifier if suction air temperature is 20°C (68°F) or above and turns OFF the humidifier if suction air temperature is 18°C (64.4°F) or below when the heating thermostat is OFF.

★: Factory setting

Mode No.	First Code No.	Second Code No.	Contents
15 (25)	1	<b>01★</b>	<b>Not equipped★</b>
		02	Equipped

### 1.5.34 Setting of Direct Duct Connection

This is used when "fresh air intake kit equipped with fan" is connected. If the second code is set to 02: Equipped, energy recovery ventilator fan conducts the fan residual operation by linking to indoor unit. The indoor fan carries out residual operation for one minute after the thermostat is stopped. (For the purpose of preventing dust on the air filter from falling off.)

★: Factory setting

Mode No.	First Code No.	Second Code No.	Contents
15 (25)	2	<b>01★</b>	<b>Not equipped★</b>
		02	Equipped

### 1.5.35 Interlocked Operation between Humidifier and Drain Pump

This is used to interlock the humidifier with the drain pump. When water is drained out of the unit, this setting is unnecessary.

★: Factory setting

Mode No.	First Code No.	Second Code No.	Contents
15 (25)	3	<b>01★</b>	<b>Not interlocked★</b>
		02	Interlocked

### 1.5.36 Individual Setting of Ventilation

This is set to perform individual operation of Energy recovery ventilator using the remote controller/central unit when Energy recovery ventilator is built in.  
(Switch only when Energy recovery ventilator is built in.)

★: Factory setting

Mode No.	First Code No.	Second Code No.	Contents
15 (25)	5	<b>01★</b>	<b>Normal★</b>
		02	Individual

### 1.5.37 Display of Error Codes on the Remote Controller

■ For BRC1E73 only

Error code (four digits) is displayed for limited products.

Select two-digit display if four-digit display is not preferred.

★: Factory setting

Mode No.	First Code No.	Second Code No.	Contents
1b	4	01	—
		02	Two-digit display
		03	—
		<b>04★</b>	<b>Four-digit display★</b>

### 1.5.38 Room Temperature Display

■ For BRC1E73 only

A "Detailed display screen" can be selected as the display screen. This setting is used if you do not want "Room temperature display" to be shown on the "Detailed display screen".

★: Factory setting

Mode No.	First Code No.	Second Code No.	Contents
1c	0	01	Not displayed.
		<b>02★</b>	<b>Displayed★</b>

### 1.5.39 Thermistor Sensor for Auto Changeover and Setback Control by the Remote Controller

■ For BRC1E73 only

Select a thermistor to utilize for the cool/heat mode automatic changeover and setback functions. The sensed temperature will be displayed on the remote controller as the room temperature.

★: Factory setting

Mode No.	First Code No.	Second Code No.	Contents
1c	1	01	Utilize the return air thermistor
		<b>02★</b>	<b>Utilize the remote controller thermistor★</b>

## 1.5.40 Access Permission Level Setting

### ■ For BRC1E73 only

There are 2 levels as follows:

- Level 2: The following buttons are selectable to be disable or enable.
- Level 3: No buttons are selectable and only **On/Off** button is available.

Button	Level 2	Level 3
	Selectable (Enable)	Unselectable (Disable)
On/Off	Selectable (Enable)	Unselectable (Enable)
Mode	Selectable (Enable)	Unselectable (Disable)
Fan Speed	Selectable (Disable)	Unselectable (Disable)
Menu/OK	Unselectable (Disable)	Unselectable (Disable)
Cancel	Unselectable (Disable)	Unselectable (Disable)

( ) shows the factory setting.

★: Factory setting

Mode No.	First Code No.	Second Code No.	Contents
1c	3	<u>01</u> ★	<u>Level 2</u> ★
		02	Level 3

## 1.5.41 Setback Availability

### ■ For BRC1E73 only

Select the operation mode in which the setback function is available.

★: Factory setting

Mode No.	First Code No.	Second Code No.	Contents
1e	2	<u>01</u> ★	<u>N/A</u> ★
		02	Heat only
		03	Cool only
		04	Cool/heat

## 1.5.42 Setting "Restricted/Permitted" for Airflow Block

### ■ For units with the infrared presence/floor sensor only

The airflow block function cannot be enabled when closure material kit, fresh air intake kit, separately installed natural evaporation type humidifier, or branch air duct is equipped, due to the possibility of dew condensation.

This setting restricts the airflow block function, preventing that the airflow block is inadvertently set to ON.

Ensure that "Airflow block restricted" is set when using the options listed above.

★: Factory setting

Mode No.	First Code No.	Second Code No.	Contents
1e	14	<u>01</u> ★	<u>Airflow block permitted</u> ★
		02	—
		03	—
		04	—
		05	Airflow block restricted

# 1.6 Gas Furnace Set Up

Set-up for gas furnace is possible only by using the DIP switches located on CXTQ-TA. Gas furnace's DIP switch is not valid. Refer to the gas furnace's installation manual for details of each setting menu.



**Note(s)**

If the Heat OFF Delay time was changed to a longer time, warm-up process time of the heat pump might be longer.

★: Factory setting

Purpose	Function		Position			
	Modulating	2-Stage	1	2	3	4

Dip switch			DS1			
Heat Airflow Trim	-15%	-10%	OFF	OFF	OFF	OFF
	-12%	-8%	ON	OFF	OFF	OFF
	-9%	-6%	OFF	ON	OFF	OFF
	-6%	-4%	ON	ON	OFF	OFF
	-3%	-2%	OFF	OFF	ON	OFF
	<b>0%★</b>	<b>0%★</b>	<b>ON★</b>	<b>OFF★</b>	<b>ON★</b>	<b>OFF★</b>
	+3%	+2%	OFF	ON	ON	OFF
	+6%	+4%	ON	ON	ON	OFF
	+9%	+6%	OFF	OFF	OFF	ON
	+12%	+8%	ON	OFF	OFF	ON
	+15%	+10%	OFF	ON	OFF	ON
	0%		ON	ON	OFF	ON
	0%		OFF	OFF	ON	ON
	0%		ON	OFF	ON	ON
0%		OFF	ON	ON	ON	
0%		ON	ON	ON	ON	

Dip switch		DS2			
Heat ON Delay	5 sec.	OFF	OFF	OFF	—
	10 sec.	ON	OFF	OFF	—
	15 sec.	OFF	ON	OFF	—
	20 sec.	ON	ON	OFF	—
	25 sec.	OFF	OFF	ON	—
	<b>30 sec.★</b>	<b>ON★</b>	<b>OFF★</b>	<b>ON★</b>	<b>==★</b>
	30 sec.	OFF	ON	ON	—
	30 sec.	ON	ON	ON	—

Dip switch		DS3			DS2
Heat OFF Delay	<b>30 sec.★</b>	<b>OFF★</b>	<b>OFF★</b>	<b>==★</b>	<b>OFF★</b>
	60 sec.	OFF	OFF	—	ON
	90 sec.	ON	OFF	—	OFF
	120 sec.	ON	OFF	—	ON
	150 sec.	OFF	ON	—	OFF
	180 sec.	OFF	ON	—	ON
	150 sec.	ON	ON	—	OFF
	150 sec.	ON	ON	—	ON



Dip switch		DS3			
Heating Speed Tap	A	—	—	OFF	OFF
	<b>B★</b>	<b>==★</b>	<b>==★</b>	<b>ON★</b>	<b>OFF★</b>
	C	—	—	OFF	ON
	D	—	—	ON	ON

## 1.7 List of Field Settings for Outdoor-Air Processing Unit

★: Factory setting

Mode No.	First Code No.	Setting Contents	Second Code No.														
			01	02	03	04	05	06	07	08	09	10	11	12	13	14	15
10 (20)	0	Filter contamination	<b>2500 hr</b> ★	1250 hr	—	—	—	—	—	—	—	—	—	—	—	—	—
	3	Display time to clean air filter calculation	<b>Display</b> ★	No display	—	—	—	—	—	—	—	—	—	—	—	—	—
12 (22)	1	External ON/OFF input	<b>Forced OFF</b> ★	ON/OFF control	—	—	—	—	—	—	—	—	—	—	—	—	
	5	Power failure automatic reset	Not equipped	<b>Equipped</b> ★	—	—	—	—	—	—	—	—	—	—	—	—	
14 (24)	3	Discharge pipe temperature (cooling)	°C	13	14	15	16	17	<b>18</b> ★	19	20	21	22	23	24	25	
			°F	55.4	57.2	59	60.8	62.6	<b>64.4</b> ★	66.2	68	69.8	71.6	73.4	75.2	77	
	4	Discharge pipe temperature (heating)	°C	18	19	20	21	22	23	24	<b>25</b> ★	26	27	28	29	30	
			°F	64.4	66.2	68	69.8	71.6	73.4	75.2	<b>77</b> ★	78.8	80.6	82.4	84.2	86	

## 1.8 Setting of Operation Control Mode

The operation control mode is compatible with a variety of controls and operations by limiting the functions of the operation remote controller. Furthermore, operations such as remote controller ON/OFF can be limited in accordance with the combination conditions. (Refer to information on the next page.)

Central remote controller is normally available for operations. (Except when centralized monitor is connected)

### Contents of Control Modes

20 modes consisting of combinations of the following 5 operation modes with temperature and operation mode setting by remote controller can be set and displayed by operation modes 0 through 19.

- ON/OFF control impossible by remote controller  
Used when you want to turn ON/OFF by central remote controller only. (Cannot be turned ON/OFF by remote controller.)
- OFF control only possible by remote controller  
Used when you want to turn ON by central remote controller only, and OFF by remote controller only.
- Centralized  
Used when you want to turn ON by central remote controller only, and turn ON/OFF freely by remote controller during set time.
- Individual  
Used when you want to turn ON/OFF by both central remote controller and remote controller.
- Timer operation possible by remote controller  
Used when you want to turn ON/OFF by remote controller during set time and you do not want to start operation by central remote controller when time of system start is programmed.

**How to Select Operation Mode**

Whether operation by remote controller will be possible or not for turning ON/OFF, controlling temperature or setting operation mode is selected and decided by the operation mode given on the right edge of the table below.

**Example**

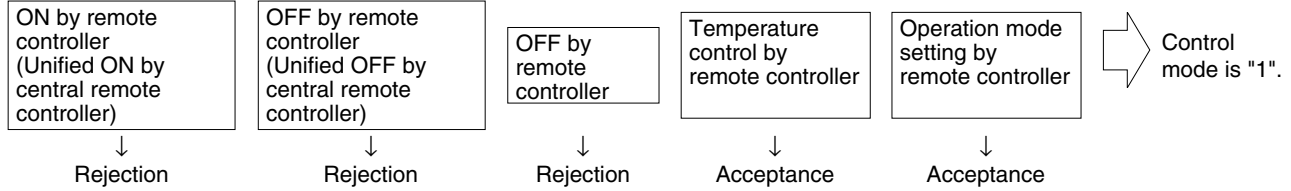

★: Factory setting

Control mode	Control by remote controller					Control mode	
	Operation		OFF	Temperature control	Operation mode setting		
	Unified operation, individual operation by central remote controller, or operation controlled by timer	Unified OFF, individual stop by central remote controller, or timer stop					
ON/OFF control impossible by remote controller	Rejection (Example)	Rejection (Example)	Rejection (Example)	Rejection	Acceptance	0	
OFF control only possible by remote controller				Acceptance (Example)	Acceptance (Example)	Acceptance (Example)	1 (Example)
					Rejection	Rejection	11
Centralized	Acceptance	Acceptance	Acceptance	Rejection	Acceptance	2	
Individual				Acceptance	Acceptance	Acceptance	3
					Rejection	Rejection	13
Timer operation possible by remote controller	Acceptance (During timer at ON position only)	Rejection (During timer at OFF position only)	Acceptance	Rejection	Acceptance	4	
				Acceptance	Rejection	14	
				Rejection	Acceptance	5	
				Acceptance	Rejection	15	
				Rejection	Acceptance	6	
				Acceptance	Rejection	16	
				Acceptance	Acceptance	<u>7</u> ★	
				Rejection	Rejection	17	
				Rejection	Acceptance	8	
				Acceptance	Rejection	18	
				Rejection	Acceptance	9	
				Acceptance	Rejection	19	

Do not select “timer operation possible by remote controller” if not using a remote controller. Operation by timer is impossible in this case.

Local remote controllers cannot set temperature or operation mode when the system is under centralized control and **CENTRAL CONTROL** is displayed on the screen.

**BRC1E73**

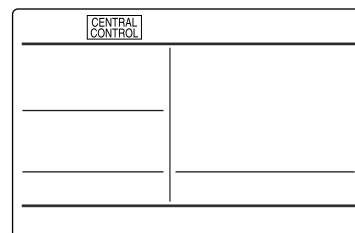

## 2. Field Settings from Outdoor Unit

### 2.1 Setting Mode and Monitor Mode

The following 3 modes can be changed over with the button switches on the PCB and you can find the present mode by the status of the H1P indicator.

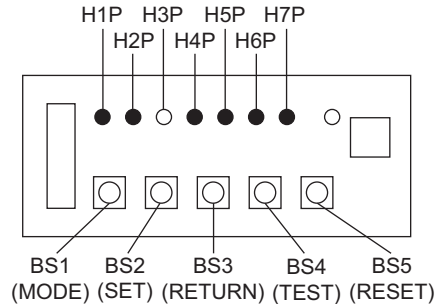

#### (1) Setting mode 1 (H1P OFF)

Initial status (normal) : Also indicates during abnormal.

#### (2) Setting mode 2 (H1P ON)

Used to modify the operating status and to set program addresses, etc. Usually used in servicing the system.

#### (3) Monitor mode (H1P blinks)

Used to check the program made in setting mode 2.

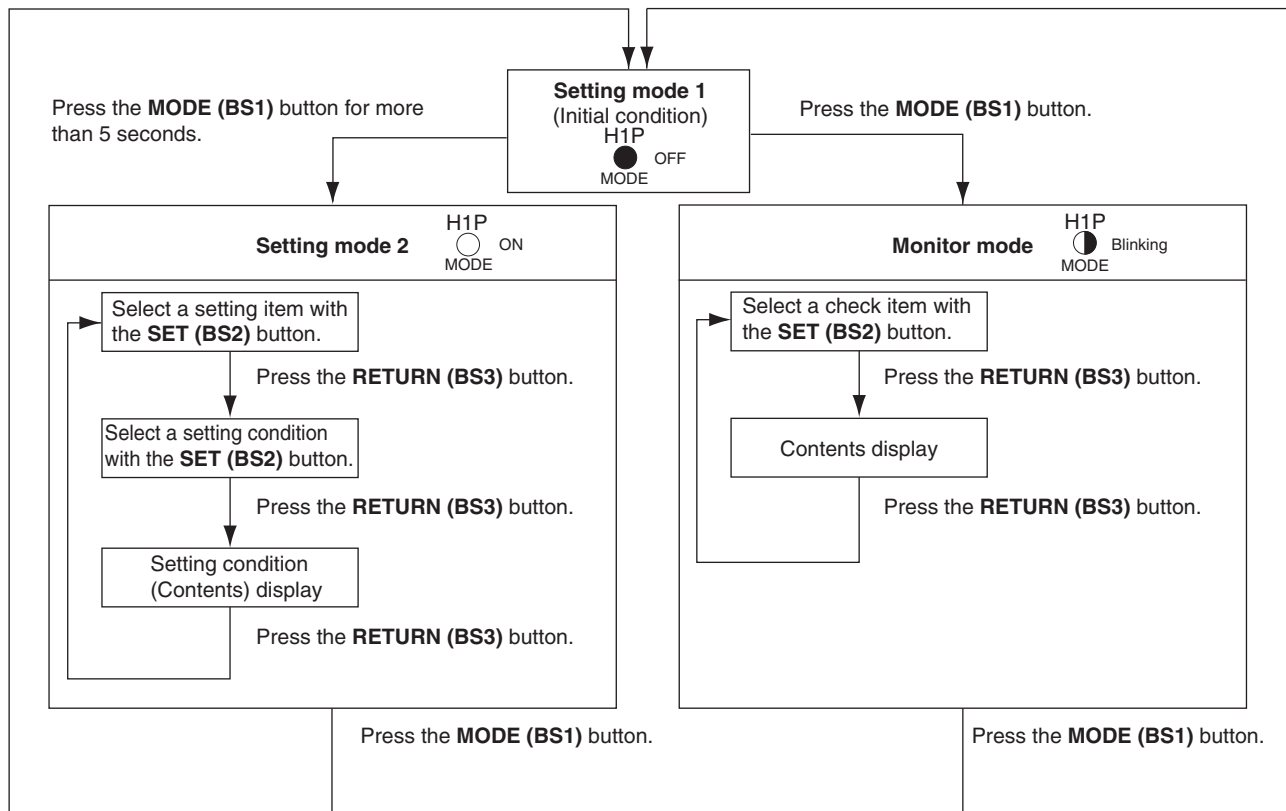

## 2.2 Setting Mode 1

This mode is used to set and check the following items.

### 1. Set items

In order to make COOL/HEAT selection in a batch of outdoor unit group, change the setting.

COOL/HEAT selection (IND)	Used to select COOL or HEAT by individual outdoor unit (factory setting).
COOL/HEAT selection (MASTER)	Used to select COOL or HEAT by outdoor unit group with the master unit.
COOL/HEAT selection (SLAVE)	Used to select COOL or HEAT by outdoor unit group with the slave unit.

### 2. Check items

The following items can be checked.

- (1) Current operating conditions (Normal / Abnormal / In check operation)
- (2) Setting conditions of COOL/HEAT selection (Individual / Batch master / Batch slave)
- (3) Low noise operating conditions (In normal operation / In low noise operation)
- (4) Demand operating conditions (In normal operation / In demand operation)

### Procedure for changing COOL/HEAT selection setting

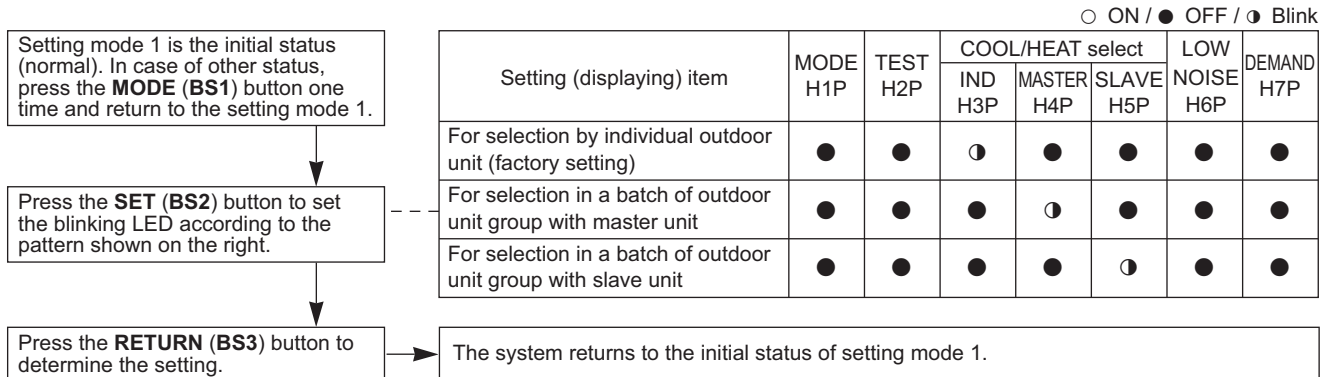

### Procedure for checking

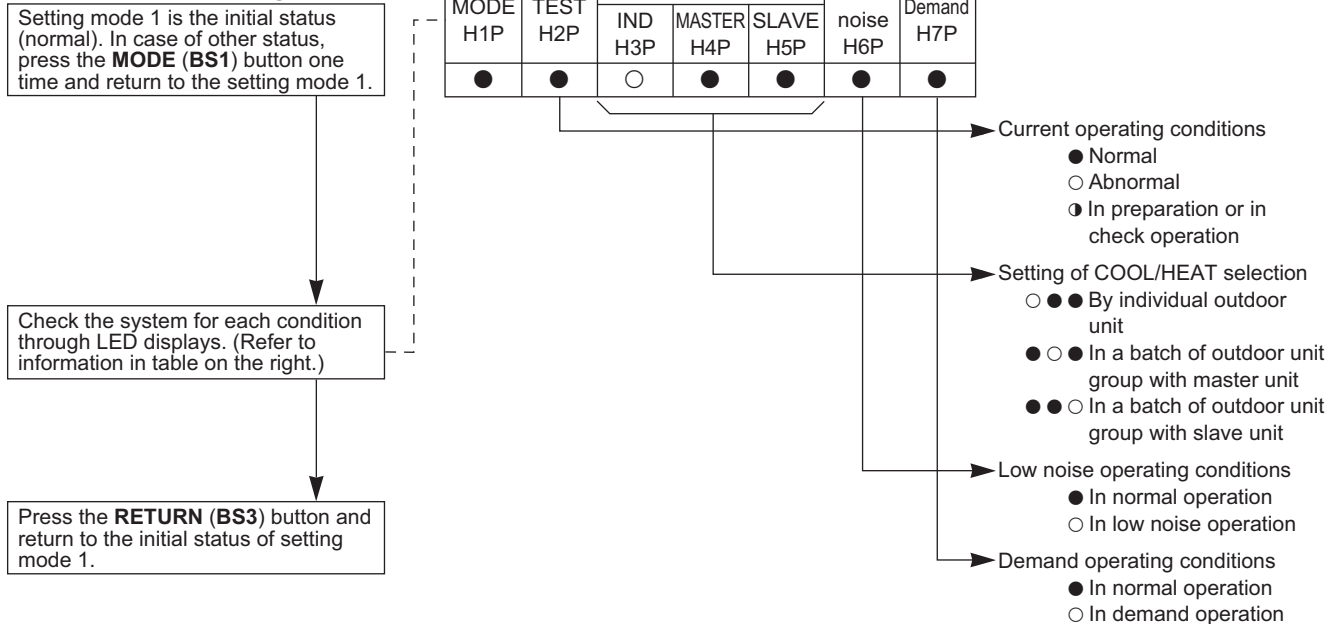

## 2.3 Setting Mode 2

Press the **MODE (BS1)** button for 5 seconds and enter the setting mode 2.

### Selection of setting items

Press the **SET (BS2)** button and select a setting item according to the LED pattern shown in the table on the right.

Press the **RETURN (BS3)** button and decide the item. (The present setting condition is shown.)

### Selection of setting conditions

Press the **SET (BS2)** button and select to the setting condition you want.

Press the **RETURN (BS3)** button and decide the condition.

Press the **RETURN (BS3)** button and return to the initial status of setting mode 2.

\* If you become unsure of how to proceed, press the **MODE (BS1)** button and return to the setting mode 1.

No.	Setting item	Description
1	Cool / heat unified address	Sets address for cool / heat unified operation.
2	Low noise / demand address	Address for low noise / demand operation
3	Test operation settings	Used to conduct test operation without making changes to the PCB and replacing the refrigerant, after the completion of maintenance.
4	Existing pipe connection	The field setting is required based on the field gas piping size and the field liquid pipe with or without thermal insulation. When there is no thermal insulation, the airflow rate of the operating indoor unit may decrease due to protection.
5	Indoor unit forced fan H	Allows forced operation of indoor fan while unit is stopped. (H tap)
6	Indoor unit forced operation	Allows forced operation of indoor unit.
7	SC adjustment	Subcooling adjustment for refrigerant addition.
8	Te setting	Target evaporation temperature for cooling
9	Tc setting	Target condensation temperature for heating
10	Defrost changeover setting	Changes the temperature condition for defrost and sets to earlier start defrost or later start defrost.
11 (*1)	TeS upper limit setting	Target evaporation temperature upper limit for cooling
12	External low noise / demand setting	Reception of external low noise or demand signal
13	AIRNET address	Set address for AIRNET.
14	Switch over ambient setting	When the temperature is lower than the set ambient temperature, operate the gas furnace instead of heat pump heat. (Gas furnace operation requiring signal : ON)
15	Switch over ambient setting (Release differential)	Differential temperature for release of "Switch over ambient setting".
16	Setting of heat pump lockout 1	Make this setting for heat pump lockout.
19	Emergency automatic heat pump lockout	Heat pump is automatically locked out in the event of a system failure.
20	Additional refrigerant charge operation setting	Carries out additional refrigerant charge operation.
21	Refrigerant recovery / vacuuming mode setting	Sets to refrigerant recovery or vacuuming mode.
22	Night-time low noise setting	Sets automatic nighttime low noise operation in a simple way. The operating time is based on Starting Set and Ending Set.
25	Setting of low noise level	Sets low noise level when the low noise signal is received.
26	Night-time low noise operation start setting	Sets starting time of nighttime low noise operation. (Night-time low noise setting is also required.)
27	Night-time low noise operation end setting	Sets ending time of nighttime low noise operation. (Night-time low noise setting is also required.)
28	Power transistor check mode *Check after disconnection of compressor wires	Used for trouble diagnosis of DC compressor. Since the waveform of inverter is output without wiring to the compressor, it is convenient to probe whether the trouble comes from the compressor or PCB.
29	Capacity precedence setting	If the capacity control is required, the low noise control is automatically released by this setting during carrying out low noise operation and night-time low noise operation.
30	Demand setting 1	Changes target value of power consumption when demand control 1 is received.
32	Constant demand setting	Enables demand control 1 without external input.
37	Setting of heat pump lockout 2	Make this setting for heat pump lockout.
41	Cooling comfort setting	Selects comfort level of VRT cooling.

The numbers in the No. column represent the number of times to press the **SET (BS2)** button.

\*1. For RXSQ48/60TB models only

No.	Setting item	Description
42	Heating comfort setting	Selects comfort level of VRT heating.
47	Heat pump lockout release differential	Heat pump would be resumed when the outdoor ambient temperature is recovered by differential above the heat pump lockout temperature.
50	Auxiliary heater maximum allowable temperature	Auxiliary heater is allowed to energize when the ambient temperature is smaller than the auxiliary heater maximum allowable temperature.
54 (*1)	TcS lower limit setting	Target condensation temperature lower limit for heating
56	Auxiliary heater maximum allowable temperature release differential	Auxiliary heater is not allowed to energize when the outdoor ambient temperature is recovered by differential above the auxiliary heater maximum allowable temperature.
57	Heat pump lockout temperature	Heat pump would be locked out when the outdoor ambient temperature is smaller than the heat pump lockout temperature. This setting is only effective when heat pump lockout mode has been set.

The numbers in the No. column represent the number of times to press the **SET (BS2)** button.

\*1. For RXSQ48/60TB models only

No.	Setting item display								Setting condition display							
	Setting item	MODE H1P	TEST H2P	C/H selection			Low noise H6P	Demand H7P			* Factory setting					
				IND H3P	Master H4P	Slave H5P										
1	Cool / heat unified address	<input type="radio"/>	<input checked="" type="radio"/>	<input checked="" type="radio"/>	<input checked="" type="radio"/>	<input checked="" type="radio"/>	<input checked="" type="radio"/>	<input checked="" type="radio"/>	<input type="radio"/>	Address 0 <input type="radio"/> <input checked="" type="radio"/> <input checked="" type="radio"/> <input checked="" type="radio"/> <input checked="" type="radio"/> <input checked="" type="radio"/> *	Binary number (6 digits) 1 <input type="radio"/> <input checked="" type="radio"/> <input checked="" type="radio"/> <input checked="" type="radio"/> <input checked="" type="radio"/> <input type="radio"/> ~ 31 <input type="radio"/> <input checked="" type="radio"/> <input type="radio"/> <input type="radio"/> <input type="radio"/> <input type="radio"/>					
2	Low noise / demand address	<input type="radio"/>	<input checked="" type="radio"/>	<input checked="" type="radio"/>	<input checked="" type="radio"/>	<input checked="" type="radio"/>	<input type="radio"/>	<input type="radio"/>	<input checked="" type="radio"/>	Address 0 <input type="radio"/> <input checked="" type="radio"/> <input checked="" type="radio"/> <input checked="" type="radio"/> <input checked="" type="radio"/> <input checked="" type="radio"/> *	Binary number (6 digits) 1 <input type="radio"/> <input checked="" type="radio"/> <input checked="" type="radio"/> <input checked="" type="radio"/> <input checked="" type="radio"/> <input type="radio"/> ~ 31 <input type="radio"/> <input checked="" type="radio"/> <input type="radio"/> <input type="radio"/> <input type="radio"/> <input type="radio"/>					
3	Test operation settings	<input type="radio"/>	<input checked="" type="radio"/>	<input checked="" type="radio"/>	<input checked="" type="radio"/>	<input checked="" type="radio"/>	<input type="radio"/>	<input type="radio"/>	<input type="radio"/>	Test operation : OFF <input type="radio"/> <input checked="" type="radio"/> <input checked="" type="radio"/> <input checked="" type="radio"/> <input checked="" type="radio"/> <input checked="" type="radio"/> <input type="radio"/>	Test operation : ON <input type="radio"/> <input checked="" type="radio"/> <input checked="" type="radio"/> <input checked="" type="radio"/> <input type="radio"/> <input checked="" type="radio"/> *					
4	Existing pipe connection	<input type="radio"/>	<input checked="" type="radio"/>	<input checked="" type="radio"/>	<input checked="" type="radio"/>	<input type="radio"/>	<input checked="" type="radio"/>	<input checked="" type="radio"/>	<input checked="" type="radio"/>	Standard pipe connection - Gas side: Standard diameter - Liquid side: Insulated <input type="radio"/> <input checked="" type="radio"/> <input checked="" type="radio"/> <input checked="" type="radio"/> <input checked="" type="radio"/> <input checked="" type="radio"/>	Existing pipe connection - Gas side: Larger pipe - Liquid side: Not insulated (*1) <input type="radio"/> <input checked="" type="radio"/> <input checked="" type="radio"/> <input checked="" type="radio"/> <input checked="" type="radio"/> <input type="radio"/>	Existing pipe connection - Gas side: Larger pipe - Liquid side: Insulated <input type="radio"/> <input checked="" type="radio"/> <input checked="" type="radio"/> <input checked="" type="radio"/> <input type="radio"/> <input checked="" type="radio"/> *	Existing pipe connection - Gas side: Standard diameter - Liquid side: Not insulated (*1) <input type="radio"/> <input checked="" type="radio"/> <input checked="" type="radio"/> <input checked="" type="radio"/> <input type="radio"/> <input type="radio"/>			
5	Indoor unit forced fan H	<input type="radio"/>	<input checked="" type="radio"/>	<input checked="" type="radio"/>	<input checked="" type="radio"/>	<input type="radio"/>	<input checked="" type="radio"/>	<input type="radio"/>	<input type="radio"/>	Normal operation <input type="radio"/> <input checked="" type="radio"/> <input checked="" type="radio"/> <input checked="" type="radio"/> <input checked="" type="radio"/> <input type="radio"/> *	Indoor forced fan H <input type="radio"/> <input checked="" type="radio"/> <input checked="" type="radio"/> <input checked="" type="radio"/> <input type="radio"/> <input checked="" type="radio"/>					
6	Indoor unit forced operation	<input type="radio"/>	<input checked="" type="radio"/>	<input checked="" type="radio"/>	<input checked="" type="radio"/>	<input type="radio"/>	<input type="radio"/>	<input type="radio"/>	<input checked="" type="radio"/>	Normal operation <input type="radio"/> <input checked="" type="radio"/> <input checked="" type="radio"/> <input checked="" type="radio"/> <input checked="" type="radio"/> <input type="radio"/> *	Indoor forced operation <input type="radio"/> <input checked="" type="radio"/> <input checked="" type="radio"/> <input checked="" type="radio"/> <input type="radio"/> <input checked="" type="radio"/>					
7	SC adjustment	<input type="radio"/>	<input checked="" type="radio"/>	<input checked="" type="radio"/>	<input checked="" type="radio"/>	<input type="radio"/>	<input type="radio"/>	<input type="radio"/>	<input type="radio"/>	ON <input type="radio"/> <input checked="" type="radio"/> <input checked="" type="radio"/> <input checked="" type="radio"/> <input type="radio"/> <input checked="" type="radio"/> *	OFF <input type="radio"/> <input checked="" type="radio"/> <input checked="" type="radio"/> <input checked="" type="radio"/> <input checked="" type="radio"/> <input type="radio"/>					
8	Te setting	<input type="radio"/>	<input checked="" type="radio"/>	<input checked="" type="radio"/>	<input type="radio"/>	<input checked="" type="radio"/>	<input checked="" type="radio"/>	<input checked="" type="radio"/>	<input checked="" type="radio"/>	Target Te: 11°C (51.8°F) <input type="radio"/> <input checked="" type="radio"/> <input checked="" type="radio"/> <input type="radio"/> <input type="radio"/> <input type="radio"/>	10°C (50°F) <input type="radio"/> <input checked="" type="radio"/> <input checked="" type="radio"/> <input type="radio"/> <input type="radio"/> <input checked="" type="radio"/>	9°C (48.2°F) <input type="radio"/> <input checked="" type="radio"/> <input checked="" type="radio"/> <input type="radio"/> <input checked="" type="radio"/> <input type="radio"/>	8°C (46.4°F) <input type="radio"/> <input checked="" type="radio"/> <input checked="" type="radio"/> <input type="radio"/> <input checked="" type="radio"/> <input checked="" type="radio"/>	Variable (VRT) <input type="radio"/> <input checked="" type="radio"/> <input checked="" type="radio"/> <input checked="" type="radio"/> <input type="radio"/> <input type="radio"/> *	6°C (42.8°F) <input type="radio"/> <input checked="" type="radio"/> <input checked="" type="radio"/> <input checked="" type="radio"/> <input type="radio"/> <input checked="" type="radio"/>	3°C (37.4°F) <input type="radio"/> <input checked="" type="radio"/> <input checked="" type="radio"/> <input checked="" type="radio"/> <input checked="" type="radio"/> <input type="radio"/>
9	Tc setting	<input type="radio"/>	<input checked="" type="radio"/>	<input checked="" type="radio"/>	<input type="radio"/>	<input checked="" type="radio"/>	<input checked="" type="radio"/>	<input type="radio"/>	<input type="radio"/>	Target Tc: 52°C (125.6°F) <input type="radio"/> <input checked="" type="radio"/> <input checked="" type="radio"/> <input type="radio"/> <input checked="" type="radio"/> <input checked="" type="radio"/>	46°C (114.8°F) <input type="radio"/> <input checked="" type="radio"/> <input checked="" type="radio"/> <input checked="" type="radio"/> <input type="radio"/> <input checked="" type="radio"/> *	Variable (VRT) <input type="radio"/> <input checked="" type="radio"/> <input checked="" type="radio"/> <input checked="" type="radio"/> <input checked="" type="radio"/> <input type="radio"/>				
10	Defrost changeover setting	<input type="radio"/>	<input checked="" type="radio"/>	<input checked="" type="radio"/>	<input type="radio"/>	<input checked="" type="radio"/>	<input type="radio"/>	<input checked="" type="radio"/>	<input checked="" type="radio"/>	Earlier start defrost <input type="radio"/> <input checked="" type="radio"/> <input checked="" type="radio"/> <input type="radio"/> <input checked="" type="radio"/> <input checked="" type="radio"/>	Normal (factory setting) <input type="radio"/> <input checked="" type="radio"/> <input checked="" type="radio"/> <input checked="" type="radio"/> <input type="radio"/> <input checked="" type="radio"/> *	Later start defrost <input type="radio"/> <input checked="" type="radio"/> <input checked="" type="radio"/> <input checked="" type="radio"/> <input checked="" type="radio"/> <input type="radio"/>				
11 (*2)	TeS upper limit setting	<input type="radio"/>	<input checked="" type="radio"/>	<input checked="" type="radio"/>	<input type="radio"/>	<input checked="" type="radio"/>	<input type="radio"/>	<input type="radio"/>	<input type="radio"/>	L <input type="radio"/> <input checked="" type="radio"/> <input checked="" type="radio"/> <input checked="" type="radio"/> <input checked="" type="radio"/> <input type="radio"/>	M <input type="radio"/> <input checked="" type="radio"/> <input checked="" type="radio"/> <input checked="" type="radio"/> <input type="radio"/> <input checked="" type="radio"/> *	H <input type="radio"/> <input checked="" type="radio"/> <input checked="" type="radio"/> <input type="radio"/> <input checked="" type="radio"/> <input checked="" type="radio"/>				
12	External low noise / demand setting	<input type="radio"/>	<input checked="" type="radio"/>	<input checked="" type="radio"/>	<input type="radio"/>	<input type="radio"/>	<input checked="" type="radio"/>	<input checked="" type="radio"/>	<input checked="" type="radio"/>	External low noise/demand: NO <input type="radio"/> <input checked="" type="radio"/> <input checked="" type="radio"/> <input checked="" type="radio"/> <input checked="" type="radio"/> <input type="radio"/> *	External low noise/demand: YES <input type="radio"/> <input checked="" type="radio"/> <input checked="" type="radio"/> <input checked="" type="radio"/> <input type="radio"/> <input checked="" type="radio"/>					
13	AIRNET address	<input type="radio"/>	<input checked="" type="radio"/>	<input checked="" type="radio"/>	<input type="radio"/>	<input type="radio"/>	<input checked="" type="radio"/>	<input type="radio"/>	<input type="radio"/>	Address 0 <input type="radio"/> <input checked="" type="radio"/> <input checked="" type="radio"/> <input checked="" type="radio"/> <input checked="" type="radio"/> <input checked="" type="radio"/> *	Binary number (6 digits) 1 <input type="radio"/> <input checked="" type="radio"/> <input checked="" type="radio"/> <input checked="" type="radio"/> <input checked="" type="radio"/> <input type="radio"/> ~ 63 <input type="radio"/> <input type="radio"/> <input type="radio"/> <input type="radio"/> <input type="radio"/> <input type="radio"/>					

The numbers in the No. column represent the number of times to press the **SET (BS2)** button.  
 \*1. At the "Not insulated" setting, the airflow rate of the operating indoor unit may decrease due to protection.  
 \*2. For RXSQ48/60TB models only

No.	Setting item display								Setting condition display	
	Setting item	MODE H1P	TEST H2P	C/H selection			Low noise H6P	Demand H7P		
				IND H3P	Master H4P	Slave H5P				
14	Switch over ambient setting	<input type="radio"/>	<input checked="" type="radio"/>	<input checked="" type="radio"/>	<input type="radio"/>	<input type="radio"/>	<input type="radio"/>	<input checked="" type="radio"/>	-20.5°C (-5°F)	<input type="radio"/>
									-17.7°C (0°F)	<input type="radio"/>
									-15.0°C (5°F)	<input type="radio"/>
									-12.2°C (10°F)	<input type="radio"/>
									-9.4°C (15°F)	<input type="radio"/>
									-6.6°C (20°F)	<input type="radio"/>
									-3.8°C (25°F)	<input type="radio"/>
									-1.1°C (30°F)	<input type="radio"/>
									1.6°C (35°F)	<input type="radio"/>
									4.4°C (40°F)	<input type="radio"/>
									7.2°C (45°F)	<input type="radio"/>
									10°C (50°F)	<input type="radio"/>
									Gas furnace operation only	<input type="radio"/>
									Heat pump operation only	<input type="radio"/>
15	Switch over ambient setting (Release differential)	<input type="radio"/>	<input checked="" type="radio"/>	<input checked="" type="radio"/>	<input type="radio"/>	<input type="radio"/>	<input type="radio"/>	<input type="radio"/>	2.8°C (5°F)	<input type="radio"/>
									5.6°C (10°F)	<input type="radio"/>
									8.3°C (15°F)	<input type="radio"/>
16	Setting of heat pump lockout 1	<input type="radio"/>	<input checked="" type="radio"/>	<input type="radio"/>	<input checked="" type="radio"/>	<input checked="" type="radio"/>	<input checked="" type="radio"/>	<input checked="" type="radio"/>	OFF	<input type="radio"/>
									ON	<input type="radio"/>
19	Emergency automatic heat pump lockout	<input type="radio"/>	<input checked="" type="radio"/>	<input type="radio"/>	<input checked="" type="radio"/>	<input checked="" type="radio"/>	<input type="radio"/>	<input type="radio"/>	OFF	<input type="radio"/>
									ON	<input type="radio"/>
20	Additional refrigerant charge operation setting	<input type="radio"/>	<input checked="" type="radio"/>	<input type="radio"/>	<input checked="" type="radio"/>	<input type="radio"/>	<input checked="" type="radio"/>	<input checked="" type="radio"/>	Refrigerant charging: OFF	<input type="radio"/>
									Refrigerant charging: ON	<input type="radio"/>
21	Refrigerant recovery / vacuuming mode setting	<input type="radio"/>	<input checked="" type="radio"/>	<input type="radio"/>	<input checked="" type="radio"/>	<input type="radio"/>	<input checked="" type="radio"/>	<input type="radio"/>	Refrigerant recovery / vacuuming: OFF	<input type="radio"/>
									Refrigerant recovery / vacuuming: ON	<input type="radio"/>
22	Night-time low noise setting	<input type="radio"/>	<input checked="" type="radio"/>	<input type="radio"/>	<input checked="" type="radio"/>	<input type="radio"/>	<input type="radio"/>	<input checked="" type="radio"/>	OFF	<input type="radio"/>
									Level 1 (outdoor fan with 6 step or lower)	<input type="radio"/>
									Level 2 (outdoor fan with 5 step or lower)	<input type="radio"/>
									Level 3 (outdoor fan with 4 step or lower)	<input type="radio"/>
25	Setting of low noise level	<input type="radio"/>	<input checked="" type="radio"/>	<input type="radio"/>	<input type="radio"/>	<input checked="" type="radio"/>	<input checked="" type="radio"/>	<input type="radio"/>	Level 1 (outdoor fan with 6 step or lower)	<input type="radio"/>
									Level 2 (outdoor fan with 5 step or lower)	<input type="radio"/>
									Level 3 (outdoor fan with 4 step or lower)	<input type="radio"/>
26	Night-time low noise operation start setting	<input type="radio"/>	<input checked="" type="radio"/>	<input type="radio"/>	<input type="radio"/>	<input checked="" type="radio"/>	<input type="radio"/>	<input checked="" type="radio"/>	About 08:00 PM	<input type="radio"/>
									About 10:00 PM (factory setting)	<input type="radio"/>
									About 12:00 AM	<input type="radio"/>
27	Night-time low noise operation end setting	<input type="radio"/>	<input checked="" type="radio"/>	<input type="radio"/>	<input type="radio"/>	<input checked="" type="radio"/>	<input type="radio"/>	<input type="radio"/>	About 06:00 AM	<input type="radio"/>
									About 07:00 AM	<input type="radio"/>
									About 08:00 AM (factory setting)	<input type="radio"/>
28	Power transistor check mode	<input type="radio"/>	<input checked="" type="radio"/>	<input type="radio"/>	<input type="radio"/>	<input type="radio"/>	<input checked="" type="radio"/>	<input checked="" type="radio"/>	OFF	<input type="radio"/>
									ON	<input type="radio"/>
29	Capacity precedence setting	<input type="radio"/>	<input checked="" type="radio"/>	<input type="radio"/>	<input type="radio"/>	<input type="radio"/>	<input checked="" type="radio"/>	<input type="radio"/>	OFF	<input type="radio"/>
									ON	<input type="radio"/>

The numbers in the No. column represent the number of times to press the **SET (BS2)** button.



No.	Setting item display							Setting condition display	
	Setting item	MODE H1P	TEST H2P	C/H selection			Low noise H6P		
				IND H3P	Master H4P	Slave H5P			
30	Demand setting 1	<input type="radio"/>	<input checked="" type="radio"/>	<input type="radio"/>	<input type="radio"/>	<input type="radio"/>	<input type="radio"/>	<input checked="" type="radio"/>	60 % demand <input type="radio"/> ● ● ● ● ● ● ● ● 70 % demand <input type="radio"/> ● ● ● ● ● ● ● ● * 80 % demand <input type="radio"/> ● ● ● ● ● ● ● ●
32	Constant demand setting	<input type="radio"/>	<input type="radio"/>	<input checked="" type="radio"/>	<input checked="" type="radio"/>	<input checked="" type="radio"/>	<input checked="" type="radio"/>	<input checked="" type="radio"/>	OFF <input type="radio"/> ● ● ● ● ● ● ● ● * ON <input type="radio"/> ● ● ● ● ● ● ● ●
37	Setting of heat pump lockout 2	<input type="radio"/>	<input type="radio"/>	<input checked="" type="radio"/>	<input checked="" type="radio"/>	<input type="radio"/>	<input checked="" type="radio"/>	<input type="radio"/>	OFF <input type="radio"/> ● ● ● ● ● ● ● ● * Mode 1 <input type="radio"/> ● ● ● ● ● ● ● ● Mode 2 <input type="radio"/> ● ● ● ● ● ● ● ● Mode 3 <input type="radio"/> ● ● ● ● ● ● ● ● Mode 4 <input type="radio"/> ● ● ● ● ● ● ● ● Mode 5 <input type="radio"/> ● ● ● ● ● ● ● ● Mode 6 <input type="radio"/> ● ● ● ● ● ● ● ●
41	Cooling comfort setting	<input type="radio"/>	<input type="radio"/>	<input checked="" type="radio"/>	<input type="radio"/>	<input checked="" type="radio"/>	<input checked="" type="radio"/>	<input type="radio"/>	Eco <input type="radio"/> ● ● ● ● ● ● ● ● Mild <input type="radio"/> ● ● ● ● ● ● ● ● * Quick <input type="radio"/> ● ● ● ● ● ● ● ● Powerful <input type="radio"/> ● ● ● ● ● ● ● ●
42	Heating comfort setting	<input type="radio"/>	<input type="radio"/>	<input checked="" type="radio"/>	<input type="radio"/>	<input checked="" type="radio"/>	<input type="radio"/>	<input checked="" type="radio"/>	Eco <input type="radio"/> ● ● ● ● ● ● ● ● Mild <input type="radio"/> ● ● ● ● ● ● ● ● * Quick <input type="radio"/> ● ● ● ● ● ● ● ● Powerful <input type="radio"/> ● ● ● ● ● ● ● ●
47	Heat pump lockout release differential	<input type="radio"/>	<input type="radio"/>	<input checked="" type="radio"/>	<input type="radio"/>	<input type="radio"/>	<input type="radio"/>	<input type="radio"/>	2.8°C (5°F) <input type="radio"/> ● ● ● ● ● ● ● ● 5.6°C (10°F) <input type="radio"/> ● ● ● ● ● ● ● ● * 8.3°C (15°F) <input type="radio"/> ● ● ● ● ● ● ● ●
50	Auxiliary heater maximum allowable temperature	<input type="radio"/>	<input type="radio"/>	<input type="radio"/>	<input checked="" type="radio"/>	<input checked="" type="radio"/>	<input type="radio"/>	<input checked="" type="radio"/>	-17.7°C (0°F) <input type="radio"/> ● ● ● ● ● ● ● ● -15°C (5°F) <input type="radio"/> ● ● ● ● ● ● ● ● -12.2°C (10°F) <input type="radio"/> ● ● ● ● ● ● ● ● -9.4°C (15°F) <input type="radio"/> ● ● ● ● ● ● ● ● -6.6°C (20°F) <input type="radio"/> ● ● ● ● ● ● ● ● -3.8°C (25°F) <input type="radio"/> ● ● ● ● ● ● ● ● -1.1°C (30°F) <input type="radio"/> ● ● ● ● ● ● ● ● 1.6°C (35°F) <input type="radio"/> ● ● ● ● ● ● ● ● * 4.4°C (40°F) <input type="radio"/> ● ● ● ● ● ● ● ● 7.2°C (45°F) <input type="radio"/> ● ● ● ● ● ● ● ● 10°C (50°F) <input type="radio"/> ● ● ● ● ● ● ● ● 12.7°C (55°F) <input type="radio"/> ● ● ● ● ● ● ● ● 15.5°C (60°F) <input type="radio"/> ● ● ● ● ● ● ● ● 18.3°C (65°F) <input type="radio"/> ● ● ● ● ● ● ● ● Auxiliary heater always not allowed <input type="radio"/> ● ● ● ● ● ● ● ● Auxiliary heater always allowed <input type="radio"/> ● ● ● ● ● ● ● ●
54 (*1)	TcS lower limit setting	<input type="radio"/>	<input type="radio"/>	<input type="radio"/>	<input checked="" type="radio"/>	<input type="radio"/>	<input type="radio"/>	<input checked="" type="radio"/>	LL <input type="radio"/> ● ● ● ● ● ● ● ● L <input type="radio"/> ● ● ● ● ● ● ● ● M <input type="radio"/> ● ● ● ● ● ● ● ● * H <input type="radio"/> ● ● ● ● ● ● ● ●

The numbers in the No. column represent the number of times to press the SET (BS2) button.  
\*1. For RXSQ48/60TB models only

No.	Setting item display								Setting condition display	
	Setting item	MODE H1P	TEST H2P	C/H selection			Low noise H6P	Demand H7P		
				IND H3P	Master H4P	Slave H5P				
56	Auxiliary heater maximum allowable temperature release differential	<input type="radio"/>	<input type="radio"/>	<input type="radio"/>	<input type="radio"/>	<input checked="" type="radio"/>	<input checked="" type="radio"/>	<input checked="" type="radio"/>	2.8°C (5°F)	<input type="radio"/> ● ● ● ● ● ● ● ●
									5.6°C (10°F)	<input type="radio"/> ● ● ● ● ● ● ● ● *
									8.3°C (15°F)	<input type="radio"/> ● ● ● ● ● ● ● ●
57	Heat pump lockout temperature	<input type="radio"/>	<input type="radio"/>	<input type="radio"/>	<input type="radio"/>	<input checked="" type="radio"/>	<input checked="" type="radio"/>	<input type="radio"/>	-26.1°C (-15°F)	<input type="radio"/> ● ● ● ● ● ● ● ● *
									-23.3°C (-10°F)	<input type="radio"/> ● ● ● ● ● ● ● ●
									-20.5°C (-5°F)	<input type="radio"/> ● ● ● ● ● ● ● ●
									-17.7°C (0°F)	<input type="radio"/> ● ● ● ● ● ● ● ●
									-15°C (5°F)	<input type="radio"/> ● ● ● ● ● ● ● ●
									-12.2°C (10°F)	<input type="radio"/> ● ● ● ● ● ● ● ●
									-9.4°C (15°F)	<input type="radio"/> ● ● ● ● ● ● ● ●
									-6.6°C (20°F)	<input type="radio"/> ● ● ● ● ● ● ● ●
									-3.8°C (25°F)	<input type="radio"/> ● ● ● ● ● ● ● ●
									-1.1°C (30°F)	<input type="radio"/> ● ● ● ● ● ● ● ●
									1.6°C (35°F)	<input type="radio"/> ● ● ● ● ● ● ● ●
									4.4°C (40°F)	<input type="radio"/> ● ● ● ● ● ● ● ●
									7.2°C (45°F)	<input type="radio"/> ● ● ● ● ● ● ● ●
									10°C (50°F)	<input type="radio"/> ● ● ● ● ● ● ● ●
									Forced heat pump lockout	<input type="radio"/> ● ● ● ● ● ● ● ●

The numbers in the No. column represent the number of times to press the **SET (BS2)** button.

## 2.4 Monitor Mode

Press the **MODE (BS1)** button and enter the monitor mode.

**Selection of check item**

Press the **SET (BS2)** button and select a check item according to the LED pattern.

**Confirmation on check item**

Press the **RETURN (BS3)** button to display different data of check item.

Press the **RETURN (BS3)** button and return to the initial status of monitor mode.

No.	Setting item	LED display							Data display
		H1P	H2P	H3P	H4P	H5P	H6P	H7P	
0	Various setting	●	●	●	●	●	●	●	See the note below.
1	Cool / heat unified address	●	●	●	●	●	●	○	Lower 6 digits
2	Low noise / demand address	●	●	●	●	●	○	●	
3	Not used	●	●	●	●	●	○	○	
4	AIRNET address	●	●	●	●	○	●	●	
5	Number of connected indoor units	●	●	●	●	○	●	○	
7	Number of connected zone units (excluding outdoor and BS unit)	●	●	●	●	○	○	○	Lower 6 digits
8	Number of outdoor units	●	●	●	○	●	●	●	
11	Number of zone units (excluding outdoor and BS unit)	●	●	●	○	●	○	○	Lower 6 digits
12	Number of terminal blocks	●	●	●	○	○	●	●	Lower 4 digits: upper
13	Number of terminal blocks	●	●	●	○	○	●	○	Lower 4 digits: lower
14	Error description (the latest)	●	●	●	○	○	○	●	Refer to the error code table on Part 6.
15	Error description (1 cycle before)	●	●	●	○	○	○	○	
16	Error description (2 cycle before)	●	●	○	●	●	●	●	
20	Contents of retry (the latest)	●	●	○	●	○	●	●	
21	Contents of retry (1 cycle before)	●	●	○	●	○	●	○	
22	Contents of retry (2 cycle before)	●	●	○	●	○	○	●	Lower 2 digits: ○● Abnormal ●○ Normal ●● Unjudgment
25	Normal judgment of outdoor units PCB	●	●	○	○	●	●	○	

\* If you become unsure of how to proceed, press the **MODE (BS1)** button and return to the setting mode 1.

The numbers in the No. column represent the number of times to press the **SET (BS2)** button.



**Note(s) Various Settings**

		H1P	H2P	H3P	H4P	H5P	H6P	H7P
Emergency operation / backup operation setting	ON	●	●	●	○	●	●	●
	OFF	●	●	●	●	●	●	●
Defrost select setting	Short	●	●	●	●	○	●	●
	Medium	●	●	●	●	●	●	●
	Long	●	●	●	●	●	●	●
Te setting	H	●	●	●	●	●	○	●
	M	●	●	●	●	●	●	●
	L	●	●	●	●	●	●	●
Tc setting	H	●	●	●	●	●	●	○
	M	●	●	●	●	●	●	●
	L	●	●	●	●	●	●	●

Press the **SET (BS2)** button and match with the LEDs No. 1 - 15, push the **RETURN (BS3)** button, and confirm the data for each setting.

★ Data such as addresses and number of units is expressed as binary numbers; the two ways of expressing are as follows:

Figure 1

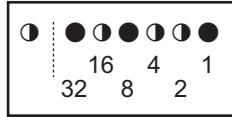

The No. 1 cool / heat unified address is expressed as a binary number consisting of the lower 6 digits. (0 - 63)

In the figure 1, the address is 010110 (binary number), which translates to  $16 + 4 + 2 = 22$  (base 10 number). In other words, the address is 22.

Figure 2

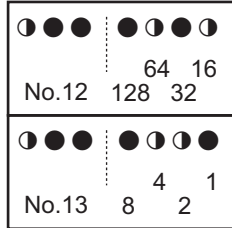

The number of terminal blocks for No. 12 and 13 is expressed as an 8-digit binary number, which is the combination of four upper, and four lower digits for No. 12 and 13 respectively. (0 - 128)

In the figure 2, the address for No. 12 is 0101, the address for No. 13 is 0110, and the combination of the two is 01010110 (binary number), which translates to  $64 + 16 + 4 + 2 = 86$  (base 10 number). In other words, the number of terminal block is 86.

\*Refer to the preceding page for a list of data, etc. for No. 0 - 25.

## 2.5 Setting of Low Noise Operation and Demand Operation

### Setting of Low Noise Operation

By connecting the external contact input to the low noise input of the external control adaptor for outdoor unit (optional), you can lower operating noise by 2-3 dB.

#### When the low noise operation is automatically carried out at night (The external control adaptor for outdoor unit is not required)

1. While in setting mode 2, select the setting condition (i.e., Mode 1, Mode 2, or Mode 3) for set item No. 22 (Setting of night-time low noise level).
2. If necessary, while in setting mode 2, select the setting condition (i.e., 8:00 PM, 10:00 PM, or 12:00 AM) for set item No. 26 (Setting of start time of night-time low noise operation).  
(Use the start time as a guide since it is estimated according to outdoor temperatures.)
3. If necessary, while in setting mode 2, select the setting condition (i.e., 06:00 AM, 07:00 AM, or 08:00 AM) for set item No. 27 (Setting of end time of night-time low noise operation).  
(Use the end time as a guide since it is estimated according to outdoor temperatures.)
4. If necessary, while in setting mode 2, set the setting condition for set item No. 29 (Setting of capacity precedence) to ON.  
(If the condition is set to ON, when the air-conditioning load reaches a high level, the system enters to normal operation mode even during night-time.)

### Image of operation

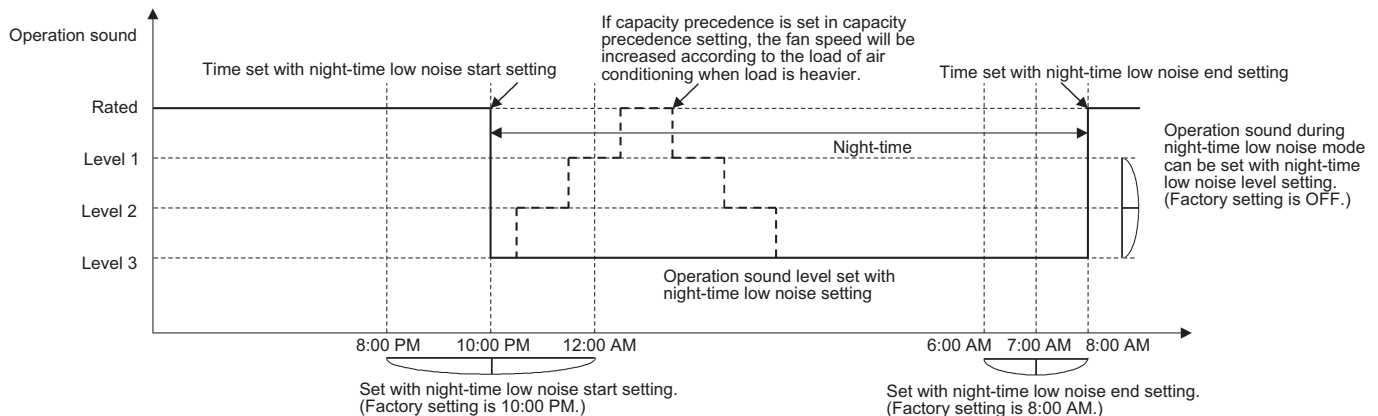

## Setting of Demand Operation

By connecting the external contact input to the demand input of the external control adaptor for outdoor unit (optional), the power consumption of unit operation can be saved suppressing the compressor operating condition.

Set item	Condition	Content
Demand	Mode 1	The compressor operates at 60% or less of rating.
	Mode 2	The compressor operates at 70% or less of rating.
	Mode 3	The compressor operates at 80% or less of rating.

**When the constant demand operation is carried out. (Use of the external control adaptor for outdoor unit is not required.)**

1. While in setting mode 2, make setting of the set item No. 32 (Setting of constant demand) to ON.
2. While in setting mode 2, select the set item No. 30 (Setting of Demand 1 level) and then set the setting condition to targeted mode.

## Image of operation

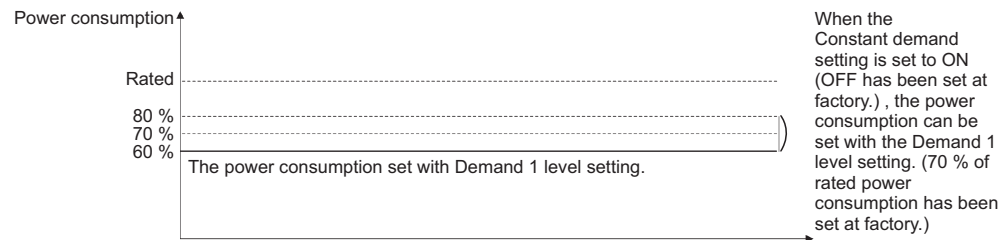

## Detailed Setting Procedure of Low Noise Operation and Demand Control

### 1. Setting mode 1 (H1P OFF)

In setting mode 2, push the **MODE (BS1)** button one time. → The system enters setting mode 1 and the H1P goes off.

In setting mode 1, the H6P (In low noise operation) and the H7P (In demand control) keep lighting.

### 2. Setting mode 2 (H1P ON)

- (1) In setting mode 1, push and hold the **MODE (BS1)** button for more than 5 seconds.  
→ The system enters setting mode 2 and the H1P lights up.
- (2) Push the **SET (BS2)** button several times and match the LED display with the Setting No. you want.
- (3) Push the **RETURN (BS3)** button one time, and the present setting content is displayed.  
→ Push the **SET (BS2)** button several times and match the LED display with the setting content (as shown on next page) you want.
- (4) Push the **RETURN (BS3)** button two times. → The system returns to (1).
- (5) Push the **MODE (BS1)** button one time. → The system returns to setting mode 1 and the H1P goes OFF.

○: ON ●: OFF ◐: Blink

Setting No.	Setting contents	(1) Setting No. indication							(2) Setting No. indication							Setting contents	(3) Setting contents indication (Initial setting)							
		H1P	H2P	H3P	H4P	H5P	H6P	H7P	H1P	H2P	H3P	H4P	H5P	H6P	H7P		H1P	H2P	H3P	H4P	H5P	H6P	H7P	
12	External low noise / demand setting	○ ● ● ● ● ● ●							○ ● ● ○ ○ ● ●							NO (Factory setting)	○	●	●	●	●	●	◐	
																YES	○	●	●	●	●	◐	●	
22	Night-time low noise setting								○ ● ○ ● ○ ○ ●							OFF (Factory setting)	○	●	●	●	●	●	●	
																Level 1	○	●	●	●	●	●	◐	
																Level 2	○	●	●	●	●	●	◐	●
																Level 3	○	●	●	●	●	●	◐	◐
26	Night-time low noise operation start setting								○ ● ○ ○ ● ○ ●							8:00 PM	○	●	●	●	●	●	◐	
																10:00 PM (Factory setting)	○	●	●	●	●	◐	●	
																12:00 AM	○	●	●	●	●	◐	●	●
27	Night-time low noise operation end setting								○ ● ○ ○ ● ○ ○							6:00 AM	○	●	●	●	●	●	◐	
																7:00 AM	○	●	●	●	●	◐	●	
																8:00 AM (Factory setting)	○	●	●	●	◐	●	●	
29	Capacity precedence setting								○ ● ○ ○ ○ ● ○							Low noise precedence (Factory setting)	○	●	●	●	●	●	◐	
																Capacity precedence	○	●	●	●	●	◐	●	
30	Demand setting 1								○ ● ○ ○ ○ ○ ●							60 % of rated power consumption	○	●	●	●	●	●	◐	
																70 % of rated power consumption (Factory setting)	○	●	●	●	●	◐	●	
																80 % of rated power consumption	○	●	●	●	◐	●	●	
32	Constant demand setting								○ ○ ● ● ● ● ●							OFF (Factory setting)	○	●	●	●	●	●	◐	
																ON	○	●	●	●	●	◐	●	

Setting mode indication section

Setting No. indication section

Set contents indication section

## 2.6 Setting of Refrigerant Recovery Mode

When carrying out the refrigerant collection on site, fully open the respective electronic expansion valve of indoor and outdoor units

All indoor and outdoor unit's operation are prohibited.

### Operation procedure

1. In setting mode 2 with units in stop mode, set the item No.21 (refrigerant recovery / vacuuming mode) to ON. The respective expansion valve of indoor and outdoor units are fully opened. **Test Operation** and **Under Centralized Control** are displayed on the remote controller, and the indoor / outdoor unit operation is prohibited. After setting, do not cancel setting mode 2 until completion of refrigerant recovery operation.
2. Collect the refrigerant using a refrigerant recovery unit. (See the instruction attached to the refrigerant recovery unit for more detail.)
3. Press the **MODE (BS1)** button once and return to setting mode 2.

## 2.7 Setting of Vacuuming Mode

In order to perform vacuuming operation on site, fully open the electronic expansion valves of indoor and outdoor units and turn on some solenoid valves.

### Operating procedure

1. In setting mode 2 with units in stop mode, set the item No.21 (refrigerant recovery / vacuuming mode) to ON. The respective expansion valve of indoor and outdoor units are fully opened. **Test Operation** and **Under Centralized Control** are displayed on the remote controller, and the indoor / outdoor unit operation is prohibited.

After setting, do not cancel setting mode 2 until completion of Vacuuming operation.

2. Use the vacuum pump to perform vacuuming operation.
3. Press the **MODE (BS1)** button once and reset setting mode 2.

## 2.8 Final Charge Adjustment

The following operation is needed only when the most adequate refrigerant charge for the best performance is required and the piping length between the outdoor and indoor units is less than 15 m (50 ft). Besides the conditions above, this final adjustment is unnecessary.

### Procedure

1. While in setting mode 2, set the item 2-20 (Additional refrigerant charge operation setting) to ON. (LEDs: ○●)
2. While in setting mode 2, set the item 2-7 (SC adjustment) to ON. (LEDs: ○●)
3. Cooling operation begins; wait until the compressor achieves charge mode rotation speed.  
Charge mode rotation speed achieved: (LEDs: ○○●●●●○○)  
Charge mode rotation speed not yet achieved: (LEDs: ○○●●●●●●)
4. Charge the refrigerant through the liquid stop valve charge port.
5. Measure the liquid stop valve temperature. Charging is complete when the temperature reaches the target subcooling.

	Target subcooling
24 class	3.33 ± 0.56°C (6 ± 1°F)
36 class	1.11 ± 0.56°C (2 ± 1°F)
48 class	6.67 ± 0.56°C (12 ± 1°F)
60 class	7.78 ± 0.56°C (14 ± 1°F)

However, for pair connection of RXSQ-TB and CXTQ-TA models, refer to the table below.

Model	Target subcooling
RXSQ24TB + CXTQ24TA	2.78 ± 0.56°C (5 ± 1°F)
RXSQ36TB + CXTQ36TA	4.44 ± 0.56°C (8 ± 1°F)
RXSQ48TB + CXTQ48TA	7.22 ± 0.56°C (13 ± 1°F)
RXSQ60TB + CXTQ60TA	10.0 ± 0.56°C (18 ± 1°F)

For RXSQ-TB models, if all connected indoor units are a combination of FXSQ-TB or FXMQ-TB, refer to the table below.

Model	Target subcooling
RXSQ24TB + FXSQ-TB, FXMQ-TB	2.78 ± 0.56°C (5 ± 1°F)
RXSQ36TB + FXSQ-TB, FXMQ-TB	2.22 ± 0.56°C (4 ± 1°F)
RXSQ48TB + FXSQ-TB, FXMQ-TB	6.11 ± 0.56°C (11 ± 1°F)
RXSQ60TB + FXSQ-TB, FXMQ-TB	5.00 ± 0.56°C (9 ± 1°F)





**Note(s)**

- The outdoor air temperature must be between 18.3°C (65°F) and 40.6°C (105°F).
- The operation is not possible when a vessel is attached to the liquid piping.
- The compressor rotation speed must be at or above that of charge mode.  
(Confirm with the LED display on the outdoor unit PCB.)
- The maximum added refrigerant for subcooling matching is 1 kg (2.2 lbs).
- Reduce the refrigerant when the subcooling degree is high.
- Refrigerant charge mode ends in 60 minutes. If 60 minutes is not long enough, begin the procedure again from step (1).
- When the discharge pipe superheat degree is low, or if the low pressure is too low, forcibly end refrigerant charge mode.

## 2.9 Check Operation

To prevent any trouble in the period of installation on site, the system is provided with a test operation mode enabling check for incorrect wiring, stop valve left in closed, coming out (or misplacing with suction pipe thermistor) or discharge pipe thermistor and judgment of piping length, refrigerant overcharging, and learning for the minimum opening degree of electronic expansion valve.

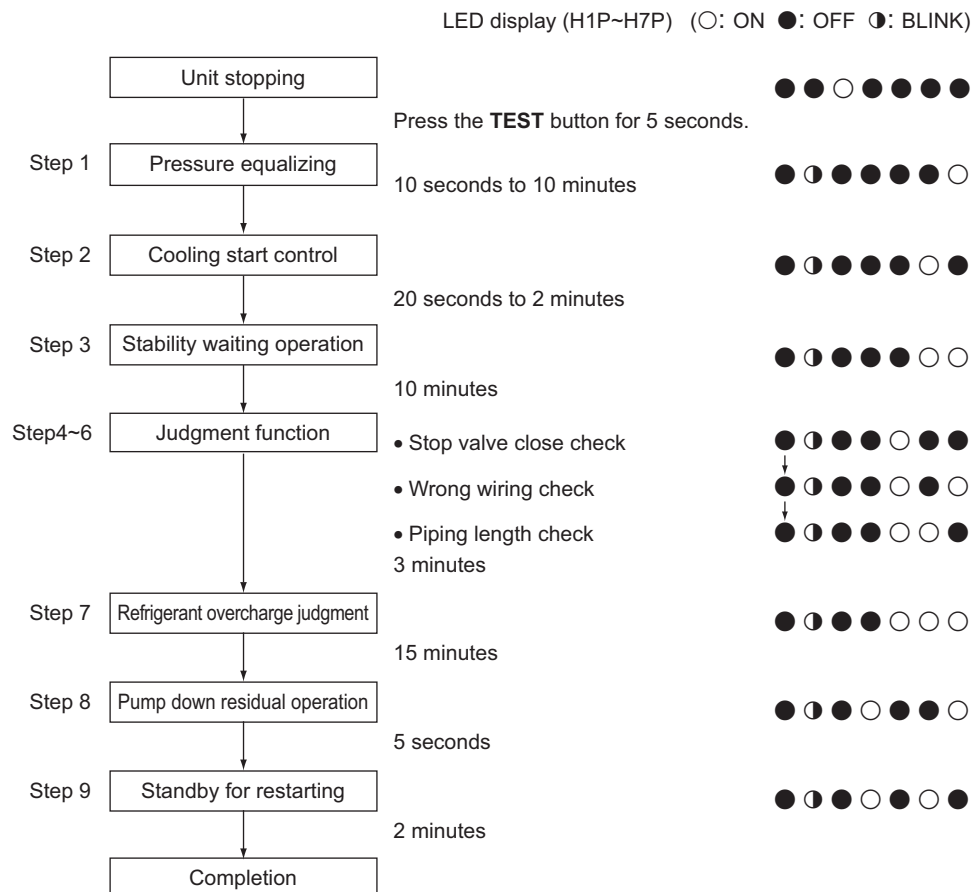

## 2.10 Setting of Auxiliary Heater Control

To improve efficiency and lower install cost the auxiliary heater can be lockout based on outdoor temperature.

### Auxiliary heater maximum allowable temperature

Auxiliary heater is allowed to energize when the outdoor air temperature is smaller than the auxiliary heater maximum allowable temperature.

No.	Setting item display								Setting condition display											
	Setting item	MODE H1P	TEST H2P	C/H selection			Low noise H6P	Demand H7P												
				IND H3P	Master H4P	Slave H5P														
50	Auxiliary heater maximum allowable temperature	○	○	○	●	●	○	●	* Factory setting											
									-17.7°C (0°F)	○	●	●	●	●	●	●	●	●	●	●
									-15°C (5°F)	○	●	●	●	●	●	○	○	○	○	○
									-12.2°C (10°F)	○	●	●	●	●	○	○	○	○	○	○
									-9.4°C (15°F)	○	●	●	●	●	○	○	○	○	○	○
									-6.6°C (20°F)	○	●	●	●	○	○	○	○	○	○	○
									-3.8°C (25°F)	○	●	●	●	○	○	○	○	○	○	○
									-1.1°C (30°F)	○	●	●	●	○	○	○	○	○	○	○
									1.6°C (35°F)	○	●	●	●	○	○	○	○	○	○	○
									4.4°C (40°F)	○	●	●	○	○	○	○	○	○	○	○
									7.2°C (45°F)	○	●	●	○	○	○	○	○	○	○	○
									10°C (50°F)	○	●	●	○	○	○	○	○	○	○	○
									12.7°C (55°F)	○	●	●	○	○	○	○	○	○	○	○
									15.5°C (60°F)	○	●	●	○	○	○	○	○	○	○	○
									18.3°C (65°F)	○	●	●	○	○	○	○	○	○	○	○
										Auxiliary heater always not allowed	○	●	●	○	○	○	○	○	○	○
	Auxiliary heater always allowed	○	●	●	○	○	○	○	○	○	○									

### Auxiliary heater maximum allowable temperature release differential

Auxiliary heater is not allowed to energize when the outdoor air temperature is recovered by differential above the auxiliary heater maximum allowable temperature.

No.	Setting item display								Setting condition display										
	Setting item	MODE H1P	TEST H2P	C/H selection			Low noise H6P	Demand H7P											
				IND H3P	Master H4P	Slave H5P													
56	Auxiliary heater maximum allowable temperature release differential	○	○	○	○	●	●	●	* Factory setting										
									2.8°C (5°F)	○	●	●	●	●	●	●	●	●	●
									5.6°C (10°F)	○	●	●	●	●	●	○	○	○	○
	8.3°C (15°F)	○	●	●	●	○	○	○	○	○	○								

## 2.11 Setting of Heat Pump Lockout and Emergency Heat Mode

Heat pump is locked out when the setting below and/or external input to ABC terminal has been made.

No.	Setting item display								Setting condition display								
	Setting item	MODE H1P	TEST H2P	C/H selection			Low noise H6P	Demand H7P									
				IND H3P	Master H4P	Slave H5P											
16	Setting of heat pump lockout 1	<input type="radio"/>	<input checked="" type="radio"/>	<input type="radio"/>	<input checked="" type="radio"/>	<input checked="" type="radio"/>	<input checked="" type="radio"/>	<input checked="" type="radio"/>	OFF	<input type="radio"/>	<input checked="" type="radio"/>	<input checked="" type="radio"/>	<input checked="" type="radio"/>	<input checked="" type="radio"/>	<input checked="" type="radio"/>	<input type="radio"/>	*
37	Setting of heat pump lockout 2	<input type="radio"/>	<input type="radio"/>	<input checked="" type="radio"/>	<input checked="" type="radio"/>	<input type="radio"/>	<input checked="" type="radio"/>	<input type="radio"/>	OFF	<input type="radio"/>	<input checked="" type="radio"/>	<input checked="" type="radio"/>	<input checked="" type="radio"/>	<input checked="" type="radio"/>	<input checked="" type="radio"/>	<input checked="" type="radio"/>	*
									Mode 1	<input type="radio"/>	<input checked="" type="radio"/>	<input checked="" type="radio"/>	<input checked="" type="radio"/>	<input checked="" type="radio"/>	<input checked="" type="radio"/>	<input type="radio"/>	
									Mode 2	<input type="radio"/>	<input checked="" type="radio"/>	<input checked="" type="radio"/>	<input checked="" type="radio"/>	<input checked="" type="radio"/>	<input type="radio"/>	<input checked="" type="radio"/>	
									Mode 3	<input type="radio"/>	<input checked="" type="radio"/>	<input checked="" type="radio"/>	<input checked="" type="radio"/>	<input checked="" type="radio"/>	<input type="radio"/>	<input type="radio"/>	
									Mode 4	<input type="radio"/>	<input checked="" type="radio"/>	<input checked="" type="radio"/>	<input checked="" type="radio"/>	<input type="radio"/>	<input checked="" type="radio"/>	<input checked="" type="radio"/>	
									Mode 5	<input type="radio"/>	<input checked="" type="radio"/>	<input checked="" type="radio"/>	<input checked="" type="radio"/>	<input type="radio"/>	<input checked="" type="radio"/>	<input type="radio"/>	
									Mode 6	<input type="radio"/>	<input checked="" type="radio"/>	<input checked="" type="radio"/>	<input checked="" type="radio"/>	<input type="radio"/>	<input type="radio"/>	<input checked="" type="radio"/>	

Type	Description	Actions						
		Field setting	Shorted between	Heating Thermo-on		Heating Thermo-off		
				Heater	Fan	Heater	Fan	
I	–	Heat-pump heating is always locked out	2-16: ON	–	ON	ON (H/L)	OFF	LL
II	Mode 1	Lockout is controlled by ABC terminals	2-37: Mode 1	A-C	ON	ON (H/L)	OFF	LL
	B-C			OFF				
	Mode 2 (for a heater which does not need airflow)		2-37: Mode 2	A-C		OFF		LL
	B-C			OFF				
	Mode 3	2-37: Mode 3	Same as 2-37: Mode 1, A-C shorted					
	Mode 4	2-37: Mode 4	Same as 2-37: Mode 1, B-C shorted					
Mode 5	2-37: Mode 5	Same as 2-37: Mode 2, A-C shorted						
Mode 6	2-37: Mode 6	Same as 2-37: Mode 2, B-C shorted						

**Heat pump lockout temperature**

Heat pump would be locked out when the outdoor air temperature is smaller than the heat pump lockout temperature. This setting is only effective when heat pump lockout mode has been set.

No.	Setting item display								Setting condition display									
	Setting item	MODE H1P	TEST H2P	C/H selection			Low noise H6P	Demand H7P										
				IND H3P	Master H4P	Slave H5P												
57	Heat pump lockout temperature	○	○	○	○	●	●	○	* Factory setting									
									-26.1°C (-15°F)	○	●	●	●	●	●	●	●	*
									-23.3°C (-10°F)	○	●	●	●	●	●	○		
									-20.5°C (-5°F)	○	●	●	●	●	○	●		
									-17.7°C (0°F)	○	●	●	●	●	○	○		
									-15°C (5°F)	○	●	●	●	○	●	●		
									-12.2°C (10°F)	○	●	●	●	○	●	○		
									-9.4°C (15°F)	○	●	●	●	○	○	●		
									-6.6°C (20°F)	○	●	●	●	○	○	○		
									-3.8°C (25°F)	○	●	●	○	●	●	●		
									-1.1°C (30°F)	○	●	●	○	●	●	○		
									1.6°C (35°F)	○	●	●	○	●	○	●		
									4.4°C (40°F)	○	●	●	○	●	○	○		
									7.2°C (45°F)	○	●	●	○	○	●	●		
10°C (50°F)	○	●	●	○	○	●	○											
	Forced heat pump lockout	○	●	●	○	○	○	●										

**Heat pump lockout release differential**

Heat pump would be resumed when the outdoor air temperature is recovered by differential above the heat pump lockout temperature.

No.	Setting item display								Setting condition display									
	Setting item	MODE H1P	TEST H2P	C/H selection			Low noise H6P	Demand H7P										
				IND H3P	Master H4P	Slave H5P												
47	Heat pump lockout release differential	○	○	●	○	○	○	○	* Factory setting									
									2.8°C (5°F)	○	●	●	●	●	●	●		
									5.6°C (10°F)	○	●	●	●	●	●	○	*	
	8.3°C (15°F)	○	●	●	●	●	○	●										

**Automatic lockout**

When heat pump lockout mode has been set, the auto backup function will automatically be set. This will allow the auxiliary or secondary heat source to be automatically energized in the event of a system failure related to outdoor units.

## 3. Test Operation

Follow the following procedure to conduct the initial test operation after installation.

### 3.1 Check Work Prior to Turning Power Supply ON

Check the below items.

- Power wiring
- Control transmission wiring between units
- Earth wire



Check on refrigerant piping / insulation material



Check on amount of refrigerant charge

- Is the power supply appropriate?
- Have you finished a ductwork to drain?
- Have you detach transport fitting?
- Is the wiring performed as specified?
- Are the designated wires used?
- Is the grounding work completed?  
Use a 500 V Megger tester to measure the insulation.  
Do not use a Megger tester for low voltage circuits.
- Are the setscrews of wiring not loose?
- Is the electrical component box covered with an insulation cover completely?

- Is pipe size proper? (The design pressure of this product is 4.0 MPa (580 psi).)
- Are pipe insulation materials installed securely?  
Liquid and gas pipes need to be insulated. (Otherwise causes water leak.)
- Are respective stop valves on liquid and gas line securely open?

- Is refrigerant charged up to the specified amount?  
If insufficient, charge the refrigerant from the service port of stop valve on the liquid side with outdoor unit in stop mode after turning power ON.
- Has the amount of refrigerant charge been recorded on "Record Chart of Additional Refrigerant Charge Amount"?

### 3.2 Turn Power ON

Turn outdoor unit power ON.



Turn indoor unit power ON.



Carry out field setting on outdoor PCB

- Be sure to turn the power ON 6 hours before starting operation to protect compressors.
- Close outside panels of the outdoor unit.

### 3.3 Test Operation

To start smoothly, a crankcase heater is equipped to the unit. To power up the crankcase heater in advance, be sure to turn on the power supply 6 hours before operation.



**Warning**

Be sure to inform other installers or attach the front panel well before leaving with the power supply turned on for the outdoor unit.

**Before powering on**

- Protect the electronic components with insulating tape in accordance with the "Service Precautions" label attached to the front panel.
- All indoor units connected with the outdoor unit will operate automatically after powering on. To ensure safety, ensure that the indoor unit installation has been completed.

**1. Powering on ~ test operation**

- Make sure to perform a test run first after installation (If the unit is operated with the indoor unit remote controller but without performing a test operation, the error code **U3** will be indicated on the display of the remote controller and the unit will not operate normally).
- After turning on the power supply, do not touch any switches excluding button switches and changeover switches when setting the outdoor unit PCB (A2P).  
(For positions of the button switches (BS1~5) and changeover switches (DS1-1, 2) on the PCB, refer to the "Service Precautions" label)
- Check the state of the outdoor units and faulty wiring with this operation.
  - (1)
    - Attach the front panel of the outdoor unit.
    - Turn on the power supply of the outdoor and indoor units.



**Caution**

To power up the crankcase heater in advance, be sure to turn on the power supply 6 hours before operation.

- (2)
  - Remove the front panel of the outdoor unit.
  - Check LED display of the outdoor unit PCB (A1P, A2P), to observe whether data transmission is normal.

Outdoor unit PCB	A1P	A2P						
	SERVICE MONITORING LAMP	MODE	READY / ABNORMAL	C/H CHANGEOVER			LOW NOISE	DEMAND
LED display (Factory setting)	HAP	H1P	H2P	IND	MASTER	SUB	H6P	H7P
	●	●	●	○	●	●	●	●

LED display ● Light OFF ○ Light ON ◐ Blinking



**Caution**

Don't touch the switches other than button switches and changeover switches of the PCB (A2P) during setting. Doing so may result in electric shock.

- (3)
  - If customer wishes to perform LOW NOISE operation or DEMAND operation, perform setting with the push buttons (BS1 ~ 5) on outdoor unit PCB (A2P).
  - Operate the push buttons from the opening of the insulating cover. (See Protective range of the "Service Precautions" label for details)



**Caution**

Power supply has been turned on for outdoor unit, be careful to avoid electric shock.

- Set the push buttons (BS1 ~ 5) after making sure the service monitoring lamp has been ON.

- For setting method, see the "Service Precautions" label attached to the front panel of the outdoor unit. (Be sure to keep a record of the setting items to the "Service Precautions" label.)
  - Don't touch the changeover switches (DS1-1) while setting them. Doing so may result in malfunction.
- (4) ● Check whether the gas side and liquid side stop valves have been opened. Open them if they are closed.

**Caution**

Operation with the stop valve closed may result in compressor malfunction.

- (5) Press **TEST (BS4)** button for 5 seconds or more to perform test operation. See About test operation on the "Service Precautions" label for details.
- Ask other installers to perform test operation or attach the front panel before having to leave the outdoor unit working alone.
  - Test operation is automatically stopped after about 30 minutes (maximum 1 hour) operation. (Perform checks of faulty wiring, closed stop valves & refrigerant charging and auto determination of piping length)
  - After test operation is completed, if there is no error code on the display of the remote controller, the unit can perform normal operation 3 minutes later.
  - The display of the remote controller indicates symbol of test operation during this operation.
- (6) Be sure to attach the front panel of the outdoor unit after test operation is completed.

**About test operation**

- 
- If the system is started about 12 minutes after the indoor and outdoor units are opened or later, the compressor will not operate and H2P will light up.  
Before operating, always check whether the symbols indicated on the LED display are those in the table under "1. Powering on ~ test operation (2)".
  - In order to ensure uniform refrigerant distribution, it may take up to around 10 minutes for the compressor to start up after the unit starting operation. This is not a malfunction.
  - The operation check is not for checking individual indoor units. After completing the operation check, operate the system normally with the remote controller.
  - Test operation can't be performed when the unit is in other modes such as refrigerant recycling mode.
  - Never perform test operation with discharge pipe thermistor (R2T), suction pipe thermistor (R3T) and pressure sensor (S1NPH, S1NPL) removed. Failure to do so will result in compressor damage.

---

## 2. For normal operation

Set the master unit (the indoor unit with cooling and heating option rights)

For wired remote controller

- After test operation is completed, the symbol **MASTER CONTROLLED** blinks on all connected remote controllers.
- Set the master unit as per customer's request.  
(It is recommended to set the indoor unit with highest frequency of use as the master unit.)
- Press the operation mode changeover button on the remote controller of the master unit.
- Conduct cool/heat changeover with this remote controller and the symbol **MASTER CONTROLLED** vanishes.
- For other remote controllers excluding the above, the symbol **MASTER CONTROLLED** lights up.

For wireless remote controller

- After test operation is completed, timer lamps blink on all connected indoor units.
- Set the master unit as per customer's request.  
(It is recommended to set the indoor unit with highest frequency of use as the master unit.)
- Press the operation mode changeover button on the remote controller of the master unit. Then a sound of beeps can be heard and the timer lamps on all indoor units go out.
- The indoor unit has the option rights to change between cooling/heating operation.

**For details, refer to the installation manual included with the indoor unit.**

- After test operation is completed, operate the unit normally.  
(Heating is not possible if the outdoor temperature is 24°C (75.2°F) or higher. Refer to the operation manual.)
  - (1) Check the indoor and outdoor units are in normal operation.  
(If a knocking sound produced by liquid compression of the compressor can be heard, stop the unit immediately.)
  - (2) Operate each indoor unit one by one and check the corresponding outdoor unit is also in operation.
  - (3) Check to see if cold (or hot) air is coming out from the indoor unit.
  - (4) Press the fan direction and strength buttons of the indoor unit to see if they operate properly.

---

### About normal operation check

- The compressor will not restart in about 5 minutes even if the **ON/OFF** button of the remote controller is pressed.
- When system operation is stopped by the remote controller, the outdoor unit may continue operating for further 1 minute at maximum.
- If any check operation was not performed through test operation on first installation, the error code **U3** will be displayed. In this case, perform check operation in accordance with "1. Powering on ~ test operation".



## 3.4 Gas Furnace Test Operation



### Caution

Always use the remote controller to stop the test operation.

The test should be performed with the following procedure.

1. All install process, including heat pump system, has been done.
2. Test operation of heat pump system has been successfully completed.
3. Turn off remote controller connected to CXTQ-TA.
4. Change the setting according to the following table.
5. Turn on remote controller connected to CXTQ-TA.
6. The compressor will be forcibly stopped if the compressor is running at this time. After that, the gas furnace will run in tens of seconds. (Tens of minutes might well be needed to stop compressor if the outdoor unit is particular operation.)
7. The gas furnace will operate with selected heat stage.
8. This test operation will stop automatically after 30 minutes or when the remote controller is turned off.

★: Factory setting

Mode No.	First Code No.	Second Code No.	Gas furnace test mode
14 (24)	11	<b>01★</b>	<b>OFF★</b>
		02	Low heat
		03	High heat



### Note(s)

- ◆ Heat pump operation is not allowed during this test operation.
- ◆ When the heat pump is in service mode (test mode, pump down mode, refrigerant charge mode, etc.), this gas furnace test will not start.
- ◆ This setting will be returned to factory setting automatically after finishing test operation.

## 3.5 Error Codes and Corresponding Measures

Please check the remote controller connected to the indoor unit for verification.

Error code	Description	Solution
E3	High pressure switch activated (S1PH)	Check the stop valve or (field) piping abnormality or the airflow on the air cooling heat exchanger.
	<ul style="list-style-type: none"> <li>• Too much refrigerant charged</li> <li>• Stop valve closed</li> </ul>	<ul style="list-style-type: none"> <li>• Check the amount of refrigerant and recharge the unit.</li> <li>• Open the stop valve.</li> </ul>
	Stop valve closed (liquid).	Open the liquid stop valve.
	<ul style="list-style-type: none"> <li>• Too much refrigerant charged</li> <li>• Stop valve closed</li> </ul>	<ul style="list-style-type: none"> <li>• Check the amount of refrigerant and recharge the unit.</li> <li>• Open the stop valve.</li> </ul>
E4	Defective low pressure: <ul style="list-style-type: none"> <li>• Stop valve closed</li> <li>• Refrigerant undercharged</li> <li>• Defective indoor unit</li> </ul>	<ul style="list-style-type: none"> <li>• Open the stop valve.</li> <li>• Check the amount of refrigerant and recharge the unit.</li> <li>• Check the user interface display.</li> <li>• Check the transmission wiring between the indoor and outdoor units.</li> </ul>
E9	Defective electronic expansion valve (Subcooling) (60 class: Y3E)	Check the connection of the PCB or the actuator.
	Defective electronic expansion valve (Main) (Y1E)	Check the connection of the PCB or the actuator.
F3	Discharge pipe temperature too high: <ul style="list-style-type: none"> <li>• Stop valve closed</li> <li>• Refrigerant undercharged</li> </ul>	<ul style="list-style-type: none"> <li>• Open the stop valve.</li> <li>• Check the amount of refrigerant and recharge the unit.</li> </ul>
H9	Defective outdoor air thermistor (R1T)	Check the connection of the PCB or the actuator.
J3	Defective discharge pipe thermistor (R2T): Tripping	Check the connection of the PCB or the actuator.
	Defective discharge pipe thermistor (R2T): Short circuit	Check the connection of the PCB or the actuator.
J5	Defective suction pipe thermistor (R3T and R5T): Tripping	Check the connection of the PCB or the actuator.
J6	Defective outdoor heat exchanger deicer thermistor (R4T)	Check the connection of the PCB or the actuator.
J7	Defective heat exchanger liquid pipe thermistor (R7T)	Check the connection of the PCB or the actuator.
J9	Defective subcooling heat exchanger gas pipe thermistor (R6T: 60 class only)	Check the connection of the PCB or the actuator.
JA	Defective high pressure sensor (S1NPH): Tripping	Check the connection of the PCB or the actuator.
	Defective high pressure sensor (S1NPH): Short circuit	Check the connection of the PCB or the actuator.
JC	Defective low pressure sensor (S1NPL): Tripping	Check the connection of the PCB or the actuator.
	Defective low pressure sensor (S1NPL): Short circuit	Check the connection of the PCB or the actuator.
P1	Inverter unbalanced power supply voltage	Check if the power supply meets the specifications.
U2	Inverter insufficient voltage	Check if the power supply meets the specifications.
	Inverter power supply phase missing	Check if the power supply meets the specifications.
U3	System test operation not yet executed (Test operation cannot be executed.)	Execute system test operation.
U4	Q1/Q2 or indoor-outdoor units wiring error	Check (Q1/Q2) wiring.
	Q1/Q2 or indoor-outdoor units wiring error	Check (Q1/Q2) wiring.
	System test operation ends abnormally.	Re-execute the test operation.
U9	System mismatch Mismatched indoor unit models used (R-410A, R-407C, RA, Hydrobox, etc.). Defective indoor unit	Check if there are any other defective indoor units and verify if the indoor unit combination meets requirements.

Error code	Description	Solution
<b>UA</b>	Defective indoor unit connection or mismatched models (R-410A, R-407C, RA, Hydrobox, etc.).	Check if there are any other defective indoor units and verify if the indoor unit combination meets requirements.
	Defective indoor unit connection or mismatched models (R-410A, R-407C, RA, Hydrobox, etc.).	Check if there are any other defective indoor units and verify if the indoor unit combination meets requirements.
	Wrong combination of units (multi-unit system)	Check the compatibility of unit types.
	Wrong combination of units (multi-unit system)	Check the compatibility of unit types.
	Gas furnace connection error	Check that two or more "CXTQ-TA + gas furnace" and other indoor units other than CXTQ-TA are not connected.
<b>UF</b>	Defective automatic addressing (inconsistency)	Check if the quantity of connected units is below the maximum number of units that can be connected (through monitor mode) or if initiation is complete.
	Stop valve closed or defective (During system test operation)	Open the stop valve.
<b>UH</b>	Defective automatic addressing (inconsistency)	Check if the quantity of connected units is below the maximum number of units that can be connected (through monitor mode) or if initiation is complete.
No display	Error in connection/communication among indoor unit remote controllers.	Check if there is any disconnection or loosening of connectors.
<b>UH-05</b>	Climate Talk Communication System Combination Error (Before Initial Setting for Communication Completes)	Power on the gas furnace. Check the Climate Talk transmission wiring. Check if unconnectable unit is on Climate Talk transmission wiring. (CXTQ-TA must have only one gas furnace certified with CXTQ-TA on the Climate Talk circuit)
<b>UH-06</b>	Climate Talk Communication System Combination Error (After Initial Setting for Communication Completes)	Check if unconnectable unit is on Climate Talk transmission wiring. (CXTQ-TA must have only one gas furnace certified with CXTQ-TA on the Climate Talk circuit)
<b>C1-08</b>	Climate Talk Communication Error	Power on the gas furnace. Check the Climate Talk transmission wiring. Do not expose the Climate Talk transmission wiring to electrical noise.
<b>A0-01</b>	External protection device abnormality	Check if 24 VAC power has been supplied to R and C terminals. Check if TB4 and TB5 terminals have not been opened. Check F1U fuse.
<b>AA-03</b>	Gas Furnace Abnormality	The gas furnace has had any error. Check 7-segment LEDs on the gas furnace PCB.

### 3.6 When Turning ON Power First Time

The unit cannot be run for up to 12 minutes to automatically set the master power and address (indoor-outdoor address, etc.).

#### Status

Outdoor unit	Test lamp H2P .... Blinks Can also be set during operation described above.
Indoor unit	If <b>ON</b> button is pushed during operation described above, the <b>UH</b> error indicator blinks. (Returns to normal when automatic setting is complete.)

### 3.7 When Turning ON Power the Second Time and Subsequent

Tap the **RESET (BS5)** button on the outdoor unit PCB. Operation becomes possible for about 2 minutes. If you do not push the **RESET (BS5)** button, the unit cannot be run for up to 10 minutes to automatically set master power.

#### Status

Outdoor unit	Test lamp H2P .... Blinks Can also be set during operation described above.
Indoor unit	If <b>ON</b> button is pushed during operation described above, the operation lamp lights but the compressor does not operate. (Returns to normal when automatic setting is complete.)

### 3.8 When an Indoor Unit or Outdoor Unit has been Added, or Indoor or Outdoor Unit PCB has been Changed

Be sure to push and hold the **RESET (BS5)** button for 5 seconds. If not, the addition cannot be recognized. In this case, the unit cannot be run for up to 12 minutes to automatically set the address (indoor-outdoor address, etc.)

#### Status

Outdoor unit	Test lamp H2P .... ON Can also be set during operation described above.
Indoor unit	If <b>ON</b> button is pushed during operation described above, the <b>UH</b> or <b>U4</b> error indicator blinks. (Returns to normal when automatic setting is complete.)

# Part 6

## Service Diagnosis

1. Servicing Items to be Confirmed .....	185
1.1 Troubleshooting.....	185
1.2 Precautions for Maintenance.....	185
1.3 Refrigerant Properties (R-410A).....	187
2. Symptom-based Troubleshooting .....	188
2.1 Indoor Unit Overall .....	188
2.2 With Optional Infrared Presence/Floor Sensor.....	191
2.3 With Gas Furnace .....	192
2.4 Gas Furnace Lockout Reset.....	192
3. Error Code via Remote Controller .....	193
3.1 Wired Remote Controller .....	193
3.2 Wireless Remote Controller .....	194
4. Error Code Indication by Outdoor Unit PCB.....	196
5. Troubleshooting by Error Code .....	200
5.1 Error Codes and Descriptions .....	200
5.2 Error Codes (Sub Codes).....	202
5.3 External Protection Device Abnormality .....	204
5.4 Indoor Unit Control PCB Abnormality .....	206
5.5 Drain Level Control System Abnormality.....	207
5.6 Indoor Fan Motor Lock, Overload.....	209
5.7 Indoor Fan Motor Abnormality .....	211
5.8 Blower Motor Not Running .....	215
5.9 Indoor Fan Motor Status Abnormality.....	216
5.10 Low Indoor Airflow .....	217
5.11 Swing Flap Motor Abnormality .....	218
5.12 Power Supply Voltage Abnormality .....	220
5.13 Blower Motor Stops for Over/Under Voltage .....	221
5.14 Electronic Expansion Valve Coil Abnormality, Dust Clogging .....	222
5.15 Gas Furnace Abnormality.....	223
5.16 Drain Level above Limit.....	224
5.17 Self-Cleaning Decoration Panel Abnormality .....	225
5.18 Capacity Determination Device Abnormality .....	236
5.19 Transmission Abnormality between Indoor Unit Control PCB and Fan PCB .....	237
5.20 Blower Motor Communication Error .....	239
5.21 Climate Talk Communication Error .....	240
5.22 Thermistor Abnormality .....	241
5.23 Combination Error between Indoor Unit Control PCB and Fan PCB .....	242
5.24 Blower Motor HP Mismatch.....	243

5.25 Indoor Blower Does Not Have Required Parameters to Function .....	244
5.26 Remote Sensor Abnormality .....	245
5.27 Humidity Sensor System Abnormality .....	246
5.28 Infrared Presence/Floor Sensor Error .....	247
5.29 Remote Controller Thermistor Abnormality .....	252
5.30 Outdoor Unit Main PCB Abnormality .....	253
5.31 Activation of High Pressure Switch .....	254
5.32 Activation of Low Pressure Sensor .....	256
5.33 Compressor Motor Lock .....	257
5.34 Outdoor Fan Motor Abnormality .....	259
5.35 Electronic Expansion Valve Coil Abnormality .....	261
5.36 Discharge Pipe Temperature Abnormality .....	262
5.37 Thermistor Abnormality .....	263
5.38 High Pressure Sensor Abnormality .....	264
5.39 Low Pressure Sensor Abnormality .....	265
5.40 Inverter PCB Abnormality .....	266
5.41 Radiation Fin Temperature Rise Abnormality .....	267
5.42 Compressor Instantaneous Overcurrent .....	268
5.43 Compressor Overcurrent .....	269
5.44 Compressor Startup Abnormality .....	270
5.45 Transmission Error between Microcomputers on Outdoor Unit Main PCB .....	271
5.46 Inverter Circuit Capacitor High Voltage .....	272
5.47 Radiation Fin Thermistor Abnormality .....	273
5.48 Refrigerant Shortage .....	274
5.49 Power Supply Insufficient or Instantaneous Abnormality .....	276
5.50 Check Operation Not Executed .....	278
5.51 Transmission Error between Indoor Units and Outdoor Units .....	279
5.52 Transmission Error between Remote Controller and Indoor Unit .....	281
5.53 Transmission Error between Main and Sub Remote Controllers .....	282
5.54 Transmission Error between Indoor Units and Outdoor Units in the Same System .....	283
5.55 Improper Combination of Indoor and Outdoor Units, Indoor Units and Remote Controller .....	284
5.56 Incorrect Gas Furnace Connecting Number .....	286
5.57 Incorrect Electric Heater Capacity Setting .....	287
5.58 Address Duplication of Centralized Controller .....	288
5.59 Transmission Error between Centralized Controller and Indoor Unit .....	289
5.60 System Not Set Yet .....	292
5.61 System Abnormality, Refrigerant System Address Undefined .....	293
5.62 Climate Talk Communication System Combination Error (Before Initial Setting for Communication Completes) .....	294
5.63 Climate Talk Communication System Combination Error (After Initial Setting for Communication Completes) .....	295
5.64 Defective PCB .....	296
5.65 Transmission Error (between Centralized Controllers) .....	297
5.66 Poor Centralized Controller Combination .....	299
5.67 Address Duplication, Poor Setting .....	301
5.68 Operation Lamp Blinking .....	303

---

5.69	Central Control Indicator Lamp Blinking (One blink) .....	305
5.70	Central Control Indicator Lamp Blinking (Two blinks) .....	308
6.	Check .....	309
6.1	High Pressure Check .....	309
6.2	Low Pressure Check .....	310
6.3	Superheat Operation Check .....	312
6.4	Power Transistor Check .....	314
6.5	Refrigerant Overcharge Check .....	315
6.6	Refrigerant Shortage Check .....	316
6.7	Vacuuming and Dehydration Procedure .....	317
6.8	List of Inverter-Related Error Codes .....	318
6.9	Concept of Inverter-Related Error Codes .....	319
6.10	Thermistor Check .....	320
6.11	Pressure Sensor Check .....	323
6.12	Master Unit Centralized Connector Setting Table .....	324
6.13	Master-Slave Unit Setting Table .....	325
6.14	Broken Wire Check of the Relay Wires .....	325
6.15	Fan Motor Connector Check (Power Supply Cable) .....	326
6.16	Fan Motor Connector Check (Signal Cable) .....	327
6.17	Electronic Expansion Valve Coil Check .....	329
6.18	Fan Motor Connector Check for FXTQ-TA .....	331

# 1. Servicing Items to be Confirmed

## 1.1 Troubleshooting

### (1) Initial verification and troubleshooting

1. Properly understand the end user's needs and issues.
2. Check the cause of errors according to the description provided by the end user.
3. Check if the remote controller displays any error codes.  
(Or use the outdoor unit monitoring mode to check for errors).
4. If there is no display of error codes, refer to **Symptom-based Troubleshooting** on page 188 for diagnosis.  
If an error code is displayed, refer to troubleshooting flowchart for diagnosis.

### (2) Take appropriate measures.

1. Repair the defect or replace the parts according to the troubleshooting results.
2. Turn off the power supply for 10 minutes before disassembling.
3. The refrigerant has to be collected before refrigerant system components are replaced.

### (3) Verification after taking appropriate measures

1. Run the unit after repairing the defect to confirm normal unit operation.
2. Record the check results and inform the client.

## 1.2 Precautions for Maintenance

Pay attention to the following matters in servicing.

### (1) Precaution for maintenance

Touch the paint-free metal part of the product (electrical box lid of the standard model; tap bolts of electrical box of anti-corrosion and heavy anti-corrosion models) to release static electricity before starting work.

### (2) Precautions for maintaining the service cover

After maintenance, make sure to close the service cover.

(Otherwise, leakage of water or contamination by foreign matter may cause defects)

### (3) Precautions for maintaining the electrical box

1. Turn off the power for 10 minutes before opening the cover of the electrical box.
2. After opening the cover, use the tester to measure the terminal voltage of the power supply terminal to make sure that the power has been cut.  
Then check if the circuit capacitor voltage is under 50 VDC.
3. To avoid PCB defects, touch the earth terminal of the electrical box with your hand when unplugging the connector to release static electricity.
4. Unplug the connectors X106A and X107A (60 class only), of the outdoor fan motor.  
When unplugging the connectors, do not touch the live parts.  
(When the outdoor fan is rotating because of strong wind, there is a risk of electric shock due to main circuit board capacitor power storage.)
5. After maintenance, reconnect the connectors of the outdoor fan in their original positions.
  - ◆ Otherwise, the remote controller will display error code **E7**, preventing normal operation.



(4) Precautions for piping work and refrigerant charging:

This unit uses R-410A refrigerant. Pay attention to the following conditions.

1. The charging pipe and the manifold tube use R-410A products for pressure maintenance and avoiding contamination by impurities (SUNISO oil, etc.).
2. Be sure to purge with nitrogen when brazing.
  - ◆ Properly perform airtightness test and vacuum drying. (Airtight test pressure: 4.0 MPa (580 psi))
  - ◆ Charge refrigerant in liquid state.

(5) Precautions for operating in servicing mode (field setting):

When a test operation is interrupted or after exiting service mode, please wait for at least one minute before entering service mode again. In case of continuous execution, the outdoor unit PCB may sometimes display an error code. If any error codes are displayed, press the **RETURN (BS3)** button. If performing the above operation still does not eliminate the error, reconnect the unit to the power supply.

### 1.3 Refrigerant Properties (R-410A)

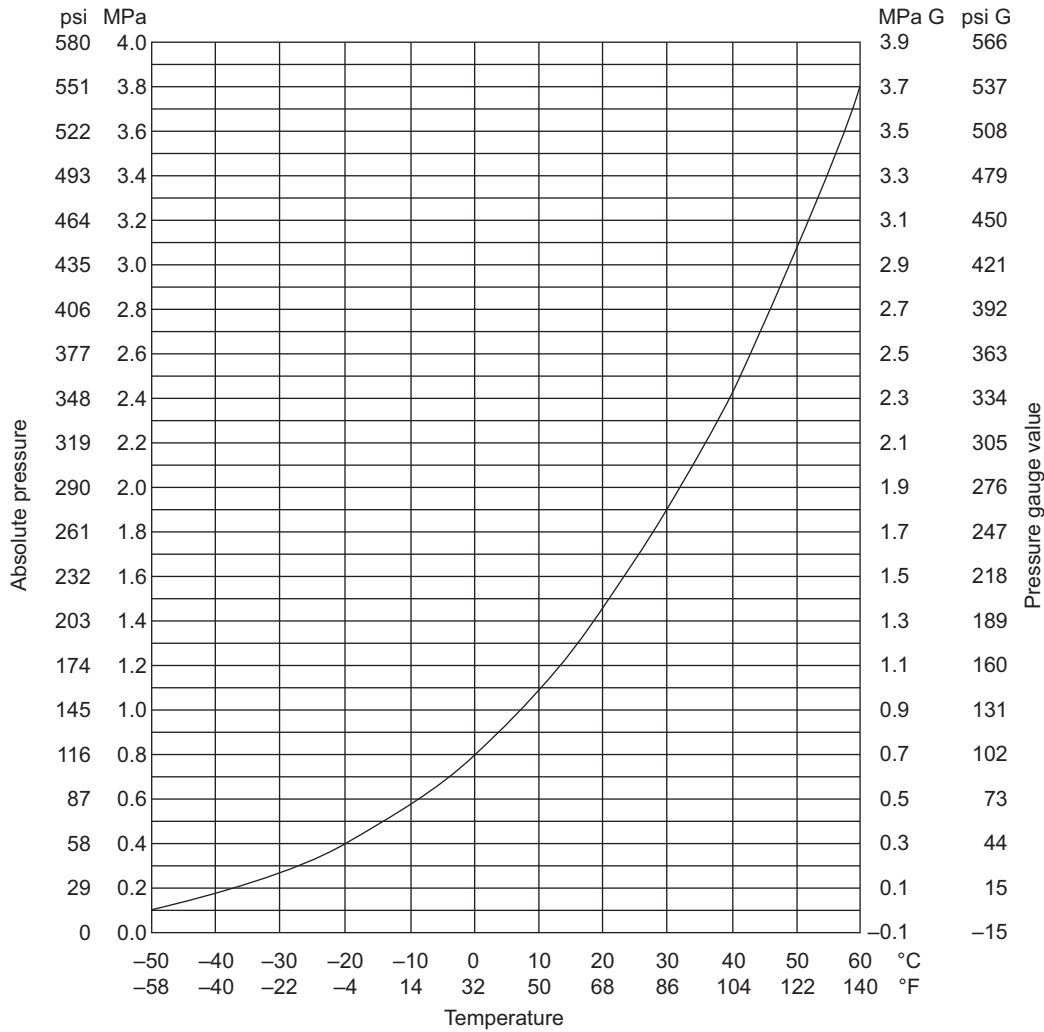

Temperature		Absolute Pressure		Temperature		Absolute Pressure		Temperature		Absolute Pressure		Temperature		Absolute Pressure	
°C	°F	MPa	psi	°C	°F	MPa	psi	°C	°F	MPa	psi	°C	°F	MPa	psi
-50	-58	0.11	16.0	-20	-4	0.40	58.0	10	50.0	1.09	158	40	104.0	2.42	351
-48	-54.4	0.12	17.4	-18	-0.4	0.43	62.4	12	53.6	1.15	167	42	107.6	2.54	368
-46	-50.8	0.13	18.9	-16	3.2	0.46	66.7	14	57.2	1.22	177	44	111.2	2.67	387
-44	-47.2	0.15	21.8	-14	6.8	0.50	72.5	16	60.8	1.29	187	46	114.8	2.80	406
-42	-43.6	0.16	23.2	-12	10.4	0.54	78.3	18	64.4	1.37	199	48	118.4	2.93	425
-40	-40	0.18	26.1	-10	14	0.57	82.7	20	68.0	1.45	210	50	122.0	3.07	445
-38	-36.4	0.19	27.6	-8	17.6	0.61	88.5	22	71.6	1.53	222	52	125.6	3.21	466
-36	-32.8	0.21	30.5	-6	21.2	0.66	95.7	24	75.2	1.61	234	54	129.2	3.36	487
-34	-29.2	0.23	33.4	-4	24.8	0.70	102	26	78.8	1.70	247	56	132.8	3.51	509
-32	-25.6	0.25	36.3	-2	28.4	0.75	109	28	82.4	1.79	260	58	136.4	3.64	528
-30	-22	0.27	39.2	0	32	0.80	116	30	86.0	1.89	274	60	140.0	3.83	555
-28	-18.4	0.29	42.1	2	35.6	0.85	123	32	89.6	1.99	289	62	143.6	4.00	580
-26	-14.8	0.32	46.4	4	39.2	0.91	132	34	93.2	2.09	303	64	147.2	4.17	605
-24	-11.2	0.34	49.3	6	42.8	0.96	139	36	96.8	2.20	319	—	—	—	—
-22	-7.6	0.37	53.7	8	46.4	1.02	148	38	100.4	2.31	335	—	—	—	—

## 2. Symptom-based Troubleshooting

### 2.1 Indoor Unit Overall

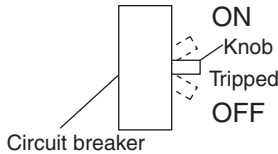
	Symptom	Supposed Cause	Countermeasure	
1	The system does not start operation at all.	Blowout of fuse(s)	Turn OFF the power supply and then replace the fuse (s).	
		Cutout of breaker(s)	<ul style="list-style-type: none"> <li>• If the knob of any breaker is in its OFF position, turn ON the power supply.</li> <li>• If the knob of any circuit breaker is in its tripped position, do not turn ON the power supply.</li> </ul>  <p>The diagram shows a vertical rectangular circuit breaker. To its right is a knob with three positions: 'ON' at the top, 'Tripped' in the middle, and 'OFF' at the bottom. A dashed line indicates the knob's movement between these positions. A label 'Circuit breaker' points to the main body of the device.</p>	
		Power failure	After the power failure is reset, restart the system.	
		The connector loose or not fully plugged in	Turn off the power supply to verify the connection of the connector.	
2	The system starts operation but makes an immediate stop.	Blocked air inlet or outlet of indoor or outdoor unit	Remove obstacle(s).	
		Clogged air filter(s)	Clean the air filter(s).	
3	The system does not cool or heat air well.	Blocked air inlet or outlet of indoor or outdoor unit	Remove obstacle(s).	
		Clogged air filter(s)	Clean the air filter(s).	
		Enclosed outdoor unit(s)	Remove the enclosure.	
		Improper set temperature	Set the temperature to a proper degree.	
		Airflow rate set to LOW	Set it to a proper airflow rate.	
		Improper direction of air diffusion	Set it to a proper direction.	
		Open window(s) or door(s)	Shut it tightly.	
		<b>IN COOLING</b> Direct sunlight received	Hang curtains or shades on windows.	
		<b>IN COOLING</b> Too many persons staying in a room	The model must be selected to match the air conditioning load.	
		<b>IN COOLING</b> Too many heat sources (e.g. OA equipment) located in a room		
	<b>IN DRYING</b> The reason is that the dry operation serves not to reduce the room temperature where possible.	Change the system to cooling operation.		
4	The system does not operate.	The system stops and immediately restarts operation.	If the operation lamp on the remote controller turns ON, the system will be normal. These symptoms indicate that the system is controlled so as not to put unreasonable loads on the system.	
		Pressing the temperature setting button immediately resets the system.		
		The remote controller displays <b>CENTRAL CONTROL</b> , which blinks for a period of several seconds when the <b>OPERATION</b> button is depressed.	The system is controlled with centralized controller. Blinking display indicates that the system cannot be operated using the remote controller.	Operate the system using the COOL/HEAT central remote controller.
		The system stops immediately after turning ON the power supply.	The system is in preparation mode of microcomputer operation.	Wait for a period of approximately one minute.
5	The system makes intermittent stops.	The remote controller displays error codes <b>U4</b> or <b>U5</b> , and the system stops but restarts after a lapse of several minutes.	The system stops due to an interruption in communication between units caused by electrical noises coming from equipment other than air conditioners.	Remove causes of electrical noises. If these causes are removed, the system will automatically restart operation.

	Symptom	Supposed Cause	Countermeasure
6	COOL/HEAT selection is disabled.	The remote controller displays <b>CENTRAL CONTROL</b> .	This remote controller has no option to select cooling operation. Use a remote controller with option to select cooling operation.
		The remote controller displays <b>CENTRAL CONTROL</b> , and the COOL/HEAT selection remote controller is provided.	COOL/HEAT selection is made using the COOL/HEAT selection remote controller. Use the COOL/HEAT selection remote controller to select cool or heat.
7	The system conducts fan operation but not cooling or heating operation.	This symptom occurs immediately after turning ON the power supply.	The system is in preparation mode of operation. Wait for a period of approximately 10 minutes.
		The remote controller displays <b>CENTRAL CONTROL</b> ; no cooling or heating operation is performed. Switch to fan operation.	In thermal storage operation, the unit is set to fan operation in cooling or heating operation, and the remote controller shows <b>CENTRAL CONTROL</b> . Normal operation.
8	The airflow rate is not reproduced according to the setting.	Even pressing the airflow rate setting button makes no changes in the airflow rate.	In heating operation, when the room temperature reaches the set degree, the outdoor unit will stop while the indoor unit is brought to fan LL operation so that no one gets cold air. Furthermore, if fan operation mode is selected when other indoor unit is in heating operation, the system will be brought to fan LL operation. Normal operation.
9	The airflow direction is not reproduced according to the setting.	The airflow direction is not corresponding to that displayed on the remote controller. The flap does not swing.	Automatic control Normal operation.
10	A white mist comes out from the system.	<b>Indoor unit</b> In cooling operation, the ambient humidity is high. (This indoor unit is installed in a place with much oil or dust.)	Uneven temperature distribution due to heavy stain of the inside of the indoor unit Clean the inside of the indoor unit.
		<b>Indoor unit</b> Immediately after cooling operation stopping, the indoor air temperature and humidity are low.	Hot gas (refrigerant) that has flowed in the indoor unit results to be vapor from the unit. Normal operation.
		<b>Indoor and outdoor units</b> After the completion of defrost operation, the system is switched to heating operation.	Defrosted moisture turns to be vapor and comes out from the units. Normal operation.

	Symptom	Supposed Cause	Countermeasure	
11	The system produces sounds.	<b>Indoor unit</b> Immediately after turning ON the power supply, indoor unit produces ringing sounds.	These are operating sounds of the electronic expansion valve of the indoor unit.	Normal operation. This sound becomes low after a lapse of approximately one minute.
		<b>Indoor and outdoor units</b> Hissing sounds are continuously produced while in cooling or defrost operation.	These sounds are produced from gas (refrigerant) flowing respectively through the indoor and outdoor units.	Normal operation.
		<b>Indoor and outdoor units</b> Hissing sounds are produced immediately after the startup or stop of the system, or the startup or stop of defrost operation.	These sounds are produced when the gas (refrigerant) stops or changes flowing.	Normal operation.
		<b>Indoor unit</b> Faint sounds are continuously produced while in cooling operation or after stopping the operation.	These sounds are produced from the drain discharge device in operation.	Normal operation.
		<b>Indoor unit</b> Creaking sounds are produced while in heating operation or after stopping the operation.	These sounds are produced from resin parts expanding and contracting with temperature changes.	Normal operation.
		<b>Indoor unit</b> Sounds like trickling or the like are produced from indoor units in the stopped state.	On <b>VRV</b> systems, these sounds are produced when other indoor units in operation. The reason is that the system runs in order to prevent oil or refrigerant from dwelling.	Normal operation.
		<b>Outdoor unit</b> Pitch of operating sounds changes.	The reason is that the compressor changes the operating frequency.	Normal operation.
12	Dust comes out from the system.	Dust comes out from the system when it restarts after the stop for an extended period of time.	Dust, which has deposited on the inside of indoor unit, is blown out from the system.	Normal operation.
13	Odors come out from the system.	In operation	Odors of room, cigarettes or else adsorbed to the inside of indoor unit are blown out.	The inside of the indoor unit should be cleaned.
14	Outdoor fan does not rotate.	In operation	The reason is that fan revolutions are controlled to put the operation to the optimum state.	Normal operation.
15	LCD display <b>88</b> or <b>Checking the connection.</b> Please stand by. appears on the remote controller.	Immediately after turning ON the power supply	The reason is that the system is checking to be sure the remote controller is normal.	Normal operation. This code is displayed for a period of approximately one minute at maximum.
16	The outdoor unit compressor or the outdoor fan does not stop.	After stopping operation	It stops in order to prevent oil or refrigerant from dwelling.	Normal operation. It stops after a lapse of approximately 5 to 10 minutes.
17	The outdoor gets hot.	While stopping operation	The reason is that the compressor is warmed up to provide smooth startup of the system.	Normal operation.
18	Hot air comes out from the system even though it stops.	Hot air is felt while the system stops.	On <b>VRV</b> systems, small quantity of refrigerant is fed to indoor units in the stopped state when other indoor units are in operation.	Normal operation.

## 2.2 With Optional Infrared Presence/Floor Sensor

	Condition	Measure
1	"Louver operation different from setting" or "No downward airflow in heating operation"	Refer to the flowchart below.
2	Individual airflow direction setting different from the actual airflow direction	· Check the "Louver operation different from setting" error diagnosis.
3	While not operating, the louver does not close completely.	Turn off the circuit breaker and then turn it on again.
4	The remote controller menu does not display energy saving operating mode for when people are not present.	Refer to <b>Infrared Presence/Floor Sensor Error (CE)</b> on page 247.
	The remote controller menu does not display the stop function for when people are not present.	
	The remote controller menu does not display the automatic draft prevention function.	
5	The menu does not display the eco-friendly display function.	No defect. Set the clock.
6	During cooling and dry operation, the louver automatically switches from horizontal (P0) to one-level downward (P1).	No defect. When relative ambient humidity is higher, automatic louver control will be activated.
7	During heating operation, the use of an airflow block will not cause other louvers to turn downward (P4).	No defect. In heating operation, if an airflow block is set, then the air outlet control outdoor the airflow block will be within the range P0-P3.
8	When using airflow block, the airflow block will be routinely lifted (become horizontal) during heating operation.	No defect. Set louver to horizontal (P0) during thermostat OFF.
9	The infrared presence sensor determines that there is someone in the room while no one is there.	Check if there are any objects that generate temperature change when moving. For example: · An electric heater with swing function · Doors, curtains, blind switches · Output of paper from a fax machine or a printer · Turning on/off of incandescent lights · Moving objects
10	The infrared presence sensor determines that there is no one in the room while someone is there.	Check for the following conditions. · Lack of movement · Facing away from the sensor · Little skin exposed · Slight movement in a place far from the sensor
11	Large difference between floor temperature and actual temperature	Check for the following conditions. · Sensor detection zone affected by solar radiation · High or low temperature objects in the sensor detection zone · Large difference between floor temperature and temperature of the living space · Sensors installed near walls may be affected by wall temperature.

**Error diagnosis of "Louver operation different from setting"**

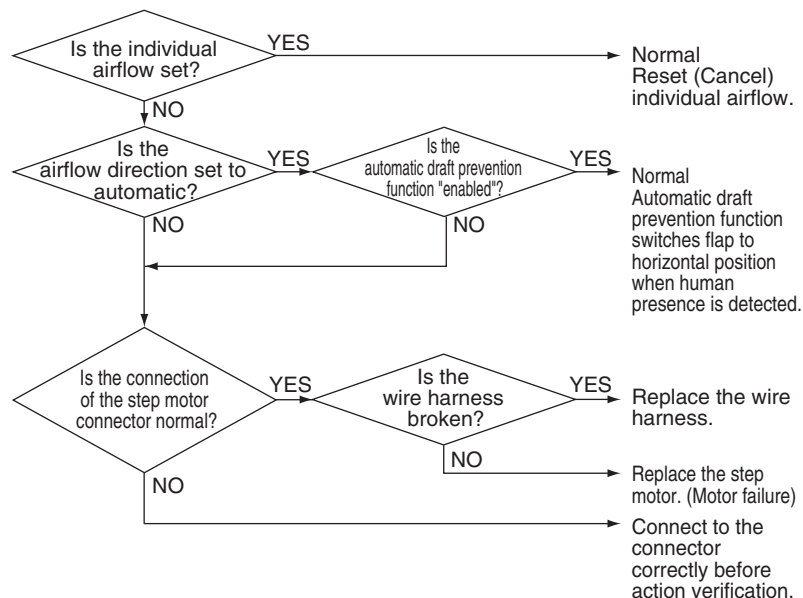

## 2.3 With Gas Furnace

	Symptom	Supposed Cause
1	The gas furnace does not start operation.	The gas furnace does not start operation while the compressor is during operation or under stop-control, or right after defrost IN or defrost OUT. Wait until the operation becomes stable.
2	Operation does not switch from heat pump to gas furnace in spite of low room temperature. Operation does not switch from gas furnace to heat pump even though the room temperature is nearing the set temperature.	<p>This function is performed only with outdoor units which support automatic switching between gas furnace and heat pump <u>interlocking with room temperature</u>. Some models are enabled to support automatic switching between gas furnace and heat pump <u>interlocking with outdoor air temperature</u> by setting heat pump lockout on an outdoor unit side. However, the compressor stops while gas furnace is during operation.</p> <p>It is possible that temperature setting for switching from heat pump to gas furnace and from gas furnace to heat pump is not appropriate. Confirm the field setting 11 (21)-1 and 11 (21)-2 and change the temperature setting for switching as needed. Refer to <b>2-Step Thermostat Processing (CXTQ-TA Models)</b> on page 122 for details.</p> <p>Operation does not switch from gas furnace to heat pump for a predetermined period of time after ignition of gas furnace to avoid frequent switching. The period of time can be changed at the field setting 11 (21)-3. Refer to <b>Gas Furnace Control (CXTQ-TA Models)</b> on page 120 for details.</p>
3	<b>AA-03</b> (Gas furnace abnormality) is indicated on the remote controller while no error is indicated on the PCB of the gas furnace.	In some cases of gas furnace abnormality, error indication on the remote controller is retained even after the abnormality is removed. Execute combustion heating operation once or reset the power source.
4	The gas furnace does not stop even when the room temperature exceeds the set temperature.	The gas furnace does not stop during defrost/oil return operation to prevent cold air from blowing out due to fan residual operation. At the field setting 11 (21)-3, the gas furnace setting can be changed not to operate during defrost/oil return operation.
5	The airflow rate indication on the remote controller is not consistent with the actual airflow rate of the indoor unit.	The airflow rate of the indoor unit during gas furnace combustion heating depends on the intensity of combustion. Therefore, the airflow rate of the indoor unit does not reflect the airflow setting of the remote controller.

## 2.4 Gas Furnace Lockout Reset

Furnace lockout is characterized by a non-functioning furnace (circulator blower may be running continuously) providing a diagnostic LED code located on the furnace board.

Lockout results when a furnace control detects abnormal conditions. If the furnace is in "lockout", the following methods can be used to clear the error.

- a. Turn the remote controller OFF to clear the error. If the error is not cleared, proceed to next step.
- b. Set the setting temperature to maximum, then turn the remote controller ON.
- c. Turn the remote controller OFF.
- d. Turn the remote controller ON after around 15 seconds from procedure c.

The procedures b, c, and d will not work during certain outdoor unit operations, i.e. defrost, startup, compressor stop, service mode etc.

If the LED of the **ON/OFF** button is flashing when you turn the remote controller ON, you cannot clear the error with the method above. In that case, the error must be cleared using the gas furnace. Refer to the gas furnace operation manual for more details.

### 3. Error Code via Remote Controller

#### 3.1 Wired Remote Controller

##### 3.1.1 BRC1E73

The following will be displayed on the screen when an error (or a warning) occurs during operation. Check the error code and take the corrective action specified for the particular model.

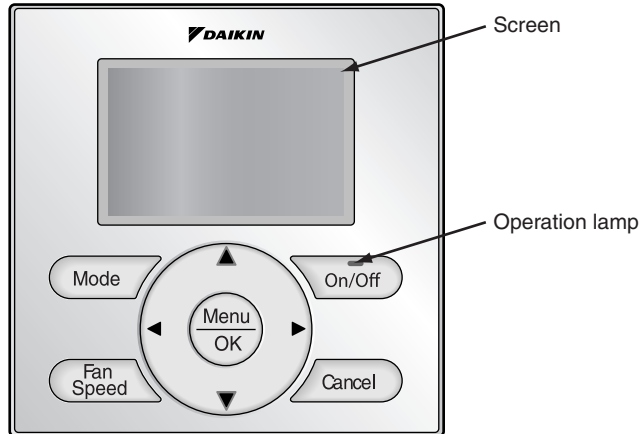

**(1) Checking an error or warning.**

	Operation Status	Display
Abnormal shutdown	The system stops operating.	<p>The operation lamp (green) starts to blink. The message <b>Error: Push Menu button</b> will blink at the bottom of the screen.</p>
Warning	The system continues its operation.	<p>The operation lamp (green) remains on. The message <b>Warning: Push Menu button</b> will blink at the bottom of the screen.</p>

**(2) Taking corrective action.**

Press the **Menu/OK** button to check the error code.



Take the corrective action specific to the model.

Error Code: A6-01		— Error code
Indoor Model	FXFQ07TVJU	— Applicable model names
Outdoor Model	RXSQ24TAVJU	



### 3.1.2 BRC1H71W

Home screen

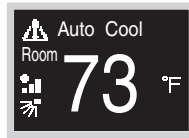

When the indoor unit is in error, the controller will display  on the home screen.

Information screen

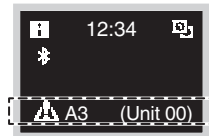



Press and hold  on the Home screen for 5 seconds. The unit number and error code will be displayed at the bottom of the information screen.

## 3.2 Wireless Remote Controller

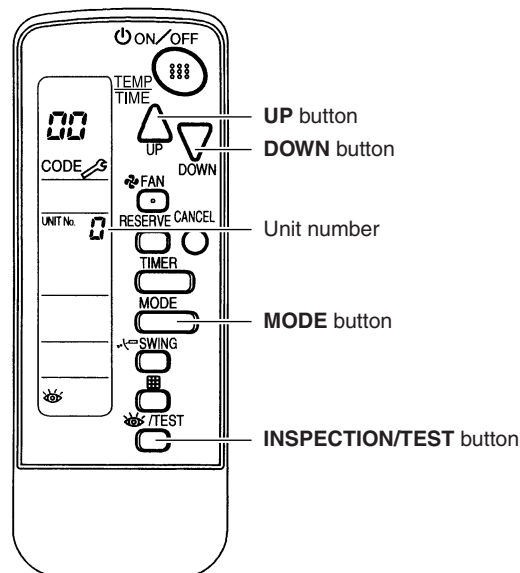
If the unit stops due to an error, the operation indicating LED on the signal receiving part of indoor unit blinks. The error code can be determined by following the procedure described below. (The error code is displayed when an operation error has occurred. In normal condition, the error code of the last problem is displayed.)



1. Press **INSPECTION/TEST** button to enter inspection mode. Then the figure  blinks on the unit number display.
2. Press **UP** button or **DOWN** button and change the unit number until the receiver of the remote controller starts to beep.
  - 3 short beeps** : Follow all steps below.
  - 1 short beep** : Follow steps 3 and 4. Continue the operation in step 4 until you hear a continuous beep. This continuous beep indicates that the error code is confirmed.
  - Continuous beep** : There is no abnormality.
3. Press **MODE** button. The left  (upper digit) indication of the error code blinks.
4. Press **UP** button or **DOWN** button to change the error code upper digit until the receiver of the indoor unit starts to beep.

- The upper digit of the code changes as shown below.

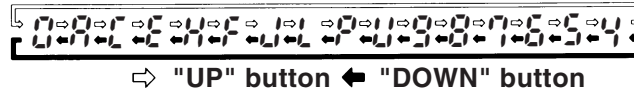

**Continuous beep** : Both upper and lower digits match. (Error code is confirmed.)

**2 short beeps** : The upper digit matches but the lower digit does not.

**1 short beep** : The lower digit does not match.

5. Press **MODE** button. The right (lower digit) indication of the error code blinks.
6. Press **UP** button or **DOWN** button and change the error code lower digit until the receiver of the indoor unit generates a continuous beep.

- The lower digit of the code changes as shown below.

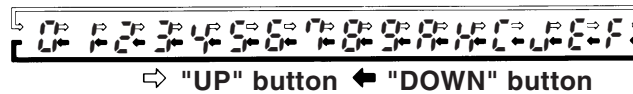

**Continuous beep** : Both upper and lower digits match. (Error code is confirmed.)

**2 short beeps** : The upper digit matches but the lower digit does not.

**1 short beep** : The upper digit does not match.

7. Press **MODE** button to return to the normal mode. If you do not press any button for 1 minute, the remote controller automatically returns to the normal mode.

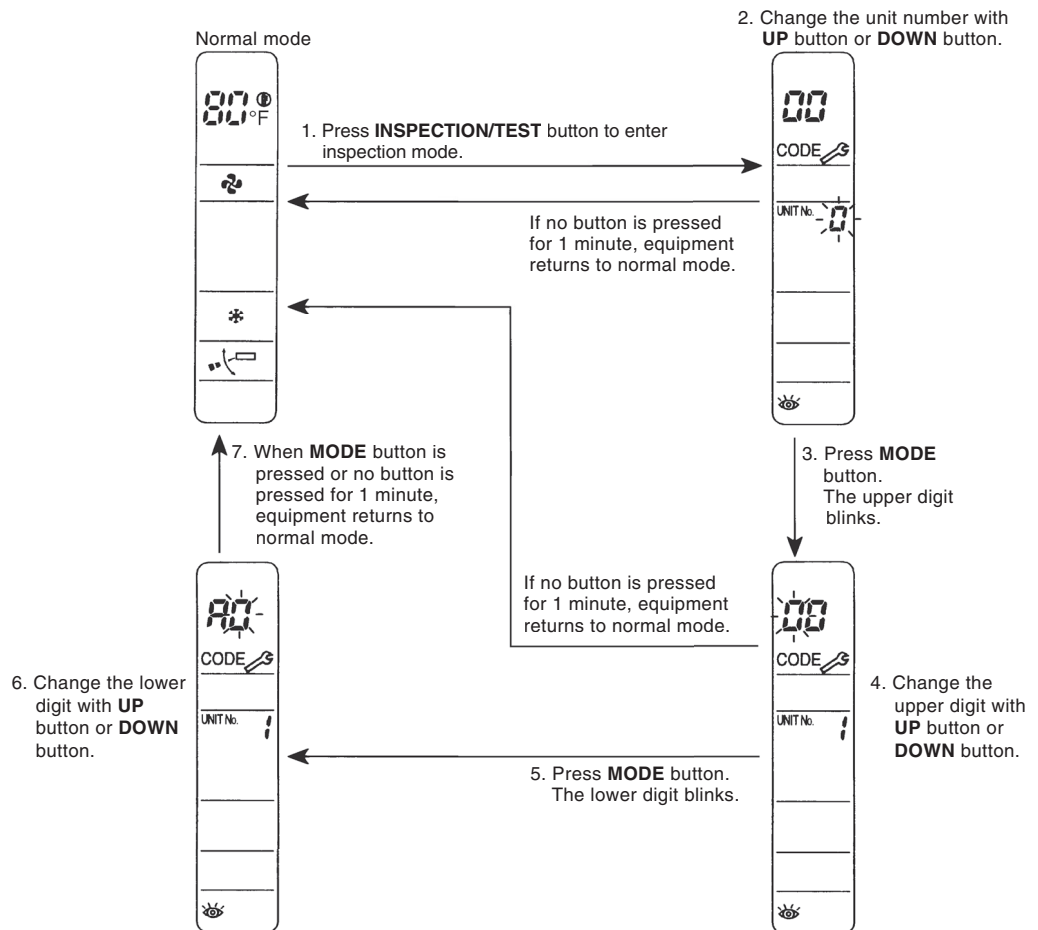

# 4. Error Code Indication by Outdoor Unit PCB

## Monitor mode

To enter the monitor mode, press the **MODE (BS1)** button when in "Setting mode 1".

## Selection of setting item

Press the **SET (BS2)** button and set the LED display to a setting item.

## Confirmation of error 1

Press the **RETURN (BS3)** button once to display "First digit" of error code.

## Confirmation of error 2

Press the **SET (BS2)** button once to display "Second digit" of error code.

## Confirmation of error 3

Press the **SET (BS2)** button once to display "error location".

## Confirmation of error 4

Press the **SET (BS2)** button once to display "master or slave 1 or slave 2" and "error location".

Press the **RETURN (BS3)** button and switches to the initial status of "Monitor mode".

Detailed description on next page.

Error Description		Error Code
PCB abnormality		E1
Abnormal high pressure switch	High pressure switch activated	E3
Abnormal low pressure switch	Low pressure switch activated	E4
Compressor lock	Detection of inverter compressor lock	E5
Overload, overcurrent, abnormal lock of outdoor fan motor	Detection of DC fan 1 motor lock	E7
	Detection of DC fan 2 motor lock	
Electronic expansion valve abnormality	Main	E9
	Subcooling	
Abnormal discharge pipe temperature	Abnormal Tdi	F3
Defective thermistor of outdoor air temperature	Defective Ta sensor (short)	H9
Defective discharge pipe thermistor	Defective Tdi sensor (short)	J3
Defective suction pipe thermistor	Defective Ts1 sensor (short)	J5
	Defective Ts2 sensor (short)	
Defective outdoor heat exchanger deicer thermistor	Defective Tb sensor (short)	J6
Defective outdoor heat exchanger liquid pipe thermistor	Defective Tl sensor (short)	J7
Defective subcooling heat exchanger gas pipe thermistor	Defective Tsh sensor (short)	J9
Defective sensor of high pressure	Defective Pc sensor (short)	JA
Defective sensor of low pressure	Defective Pe sensor (short)	JC
Defective PCB (for inverter compressor)	Defective IPM	L1
	Abnormal current sensor offset	
	Abnormal IGBT	
	Defective current sensor	
	Abnormal SP-PAM overvoltage	
	Abnormal interleave	
	Abnormal inverter jumper setting	
Abnormal EEPROM		
Inverter radiation fin temperature rising	Overheating of inverter radiation fin temperature	L4
DC output overcurrent	Inverter instantaneous overcurrent	L5
Electronic thermal	Electronic thermal switch 1	L8
	Electronic thermal switch 2	
	Out-of-step	
	Speed down after startup	
	Lightening detection	
Stall prevention (Limit time)	Stall prevention (Current increasing)	L9
	Stall prevention (Defective start up)	
	Abnormal wave form in startup	
	Out-of-step	
Transmission error (Between microcomputers on the outdoor main PCB)		LC

\* Press the **MODE (BS1)** button and return to "Setting mode 1".

○: ON ●: OFF ◐: Blink

Error Code	Confirmation of Error 1							Confirmation of Error 2							Confirmation of Error 3							Confirmation of Error 4						
	H1P	H2P	H3P	H4P	H5P	H6P	H7P	H1P	H2P	H3P	H4P	H5P	H6P	H7P	H1P	H2P	H3P	H4P	H5P	H6P	H7P	H1P	H2P	H3P	H4P	H5P	H6P	H7P
E1	◐	◐	●	●	●	◐	◐	◐	●	○	●	●	●	◐	◐	○	●	●	●	●	●	◐	○	○	●	●	◐	◐
E3								◐	●	○	●	●	◐	◐	◐	○	●	●	●	●	●	◐	○	○	●	●		
E4								◐	●	○	●	◐	●	●	◐	○	●	●	●	●	●	◐	○	○	●	●		
E5								◐	●	○	●	◐	●	●	◐	○	●	●	●	●	●	◐	○	○	●	●		
E7								◐	●	○	●	◐	◐	◐	◐	○	●	●	●	●	●	◐	○	○	●	●	◐	
E9								◐	●	○	◐	●	●	◐	◐	○	●	●	●	●	●	◐	○	○	●	●	◐	
F3	◐	◐	●	●	◐	●	◐	◐	●	○	●	●	◐	◐	◐	○	●	●	●	●	●	◐	○	○	●	●		
H9	◐	◐	●	●	◐	●	●	◐	●	○	◐	●	●	◐	◐	○	●	●	●	●	●	◐	○	○	●	●		
J3	◐	◐	●	●	◐	◐	●	◐	●	○	●	●	◐	◐	◐	○	●	●	●	●	●	◐	○	○	●	●		
J5								◐	●	○	●	◐	●	◐	◐	○	●	●	●	●	●	◐	○	○	●	●		
J6								◐	●	○	●	◐	●	◐	◐	○	●	●	●	●	●	◐	○	○	●	●		
J7								◐	●	○	●	◐	◐	◐	◐	○	●	●	●	●	●	◐	○	○	●	●		
J9								◐	●	○	◐	●	●	◐	◐	○	●	●	●	●	●	◐	○	○	●	●		
JA								◐	●	○	◐	●	◐	◐	◐	○	●	●	●	●	●	◐	○	○	●	●		
JC								◐	●	○	◐	◐	●	◐	◐	○	●	●	●	●	●	◐	○	○	●	●		
L1	◐	◐	●	●	◐	◐	◐	◐	●	○	●	●	●	◐	◐	○	●	●	●	●	●	◐	○	○	●	●	●	●
L4								◐	●	○	●	◐	●	◐	◐	○	●	●	●	●	●	◐	○	○	●	●		
L5								◐	●	○	●	◐	●	◐	◐	○	●	●	●	●	●	◐	○	○	●	●		
L8								◐	●	○	◐	●	●	◐	◐	○	●	●	●	●	●	◐	○	○	●	●		
L9								◐	●	○	◐	●	●	◐	◐	○	●	●	●	●	●	◐	○	○	●	●		
LC								◐	●	○	◐	◐	●	◐	◐	○	●	●	●	●	●	◐	○	○	●	●		

Display of error description (left side digit)

Display of error description (right side digit)

Display 1 of error in detail

Display 2 of error in detail

\*1

●	●	Master
●	◐	Slave1
◐	●	Slave2
◐	◐	System

**Monitor mode**

To enter the monitor mode, press the **MODE (BS1)** button when in "Setting mode 1".

**Selection of setting item**

Press the **SET (BS2)** button and set the LED display to a setting item.

**Confirmation of error 1**

Press the **RETURN (BS3)** button once to display "First digit" of error code.

**Confirmation of error 2**

Press the **SET (BS2)** button once to display "Second digit" of error code.

**Confirmation of error 3**

Press the **SET (BS2)** button once to display "error location".

**Confirmation of error 4**

Press the **SET (BS2)** button once to display "master or slave 1 or slave 2" and "error location".

Press the **RETURN (BS3)** button and switches to the initial status of "Monitor mode".

\* Press the **MODE (BS1)** button and return to "Setting mode 1".

Detailed description on next page.

Error Description		Error Code
Inverter over-ripple protection	Imbalance of inverter power supply voltage	P1
Defective temperature sensor of inverter radiation fin	Defective thermistor of inverter fin	P4
Refrigerant shortage	Refrigerant shortage alarm	U0
	Liquid pipe temperature abnormality	
Abnormal power supply voltage	Insufficient Inverter voltage	U2
	Open phase in inverter (Phase T)	
	Error due to SP-PAM overvoltage	
	Error due to P-N short circuit	
No implementation of test-run		U3
Transmission error between indoor and outdoor unit	I/O transmission error	U4
	Indoor unit system error	
Transmission error of other system	Indoor unit system abnormal in other system or other indoor unit system abnormal in own system	U9
Erroneous field setting	System transmission error	UA
	Overconnection error of indoor units	
	Error of field setting	
	Refrigerant abnormal	
	Connection error (BP unit)	
	Connection error (Gas furnace)	
Conflict in wiring and piping, no setting for system	Conflict in wiring and piping	UF
Defective system	Wiring error (Auto-address error)	UH

○: ON ●: OFF ◐: Blink

Error Code	Confirmation of Error 1							Confirmation of Error 2							Confirmation of Error 3							Confirmation of Error 4						
	H1P	H2P	H3P	H4P	H5P	H6P	H7P	H1P	H2P	H3P	H4P	H5P	H6P	H7P	H1P	H2P	H3P	H4P	H5P	H6P	H7P	H1P	H2P	H3P	H4P	H5P	H6P	H7P
P1	◐	◐	●	◐	●	●	◐	◐	●	○	●	●	●	◐	◐	○	●	●	●	●	●	◐	○	○	●	●	●	●
P4								◐	●	○	●	◐	●	●	◐	○	●	●	●	●	●	◐	○	○	●	●	●	●
U0	◐	◐	●	◐	●	●	◐	◐	●	○	●	●	●	◐	◐	○	●	●	●	●	●	◐	○	○	●	●	◐	◐
U2								◐	●	○	●	●	◐	●	◐	○	●	●	●	●	●	◐	○	○	●	●	●	●
																						◐	○	○	●	●	◐	◐
																						◐	○	○	●	●	◐	◐
																						◐	○	○	●	●	◐	◐
U3								◐	●	○	●	●	◐	◐	◐	○	●	●	●	●	●	◐	○	○	●	●	◐	◐
U4								◐	●	○	●	◐	●	●	◐	○	●	●	●	●	●	◐	○	○	●	●	◐	◐
U9								◐	●	○	◐	●	●	◐	◐	○	●	●	●	●	●	◐	○	○	●	●	◐	◐
																						◐	○	○	●	●	◐	◐
																						◐	○	○	●	●	◐	◐
																						◐	○	○	●	●	◐	◐
UA								◐	●	○	◐	●	◐	●	◐	○	●	●	●	●	●	◐	○	○	●	●	◐	◐
																						◐	○	○	●	●	◐	◐
																						◐	○	○	●	●	◐	◐
																						◐	○	○	●	●	◐	◐
UF								◐	●	○	◐	◐	◐	◐	◐	○	●	●	●	●	●	◐	○	○	●	●	◐	◐
UH								◐	●	○	◐	●	◐	◐	◐	○	●	●	●	●	●	◐	○	○	●	●	◐	◐

Display of error description (left side digit)
Display of error description (right side digit)
Display 1 of error in detail
Display 2 of error in detail

\*1 

●	●	Master
●	◐	Slave1
◐	●	Slave2
◐	◐	System

## 5. Troubleshooting by Error Code

### 5.1 Error Codes and Descriptions

○: ON ●: OFF ◐: Blink

	Error code	Operation lamp	Error contents	Reference page	
Indoor Unit	A0	◐	External protection device abnormality	204	
	A1	◐	Indoor unit control PCB abnormality	206	
	A3	◐	Drain level control system abnormality	207	
	A6	◐	Indoor fan motor lock, overload	209	
			Indoor fan motor abnormality	211	
			Blower motor not running	215	
			Indoor fan motor status abnormality	216	
				Low indoor airflow	217
	A7 (*1)	○	Swing flap motor abnormality	218	
	A8	◐	Power supply voltage abnormality	220	
			Blower motor stops for over/under voltage	221	
	A9	◐	Electronic expansion valve coil abnormality, dust clogging	222	
	AA	◐	Gas furnace abnormality	223	
	AF (*1)	○	Drain level above limit	224	
	AH	◐	Self-cleaning decoration panel abnormality	225	
	AJ	◐	Capacity determination device abnormality	236	
	C1	◐	Transmission abnormality between indoor unit control PCB and fan PCB	237	
			Blower motor communication error	239	
			Climate Talk communication error	240	
	C4	◐	Indoor heat exchanger liquid pipe thermistor abnormality	241	
	C5	◐	Indoor heat exchanger gas pipe thermistor abnormality	241	
	C6	◐	Combination error between indoor unit control PCB and fan PCB	242	
			Blower motor HP mismatch	243	
			Indoor blower does not have required parameters to function	244	
	C9 (*2)	◐	Suction air thermistor abnormality	241	
Remote sensor abnormality			245		
CA	◐	Discharge air thermistor abnormality	241		
CC	○	Humidity sensor system abnormality	246		
CE (*1)	○	Infrared presence/floor sensor error	247		
CJ (*2)	○	Remote controller thermistor abnormality	252		
Outdoor Unit	E1	◐	Outdoor unit main PCB abnormality	253	
	E3	◐	Activation of high pressure switch	254	
	E4	◐	Activation of low pressure sensor	256	
	E5	◐	Compressor motor lock	257	
	E7	◐	Outdoor fan motor abnormality	259	
	E9	◐	Electronic expansion valve coil abnormality	261	
	F3	◐	Discharge pipe temperature abnormality	262	
	H9	◐	Outdoor air thermistor (R1T) abnormality	263	
	J3	◐	Discharge pipe thermistor (R2T) abnormality	263	
	J5	◐	Suction pipe thermistor (R3T, R5T) abnormality	263	
	J6	◐	Outdoor heat exchanger deicer thermistor (R4T) abnormality	263	
	J7	◐	Outdoor heat exchanger liquid pipe thermistor (R7T) abnormality	263	
	J9	◐	Subcooling heat exchanger gas pipe thermistor (R6T) abnormality	263	
	JA	◐	High pressure sensor abnormality	264	
	JC	◐	Low pressure sensor abnormality	265	

	Error code	Operation lamp	Error contents	Reference page
Outdoor Unit	L1	●	Inverter PCB abnormality	266
	L4	●	Inverter radiation fin temperature rise abnormality	267
	L5	●	Compressor instantaneous overcurrent	268
	L8	●	Compressor overcurrent	269
	L9	●	Compressor startup abnormality	270
	LC	●	Transmission error between microcomputers on outdoor unit main PCB	271
	P1	●	Inverter circuit capacitor high voltage	272
	P4 (*1)	●	Radiation fin thermistor abnormality	273
System	U0 (*1)	○	Refrigerant shortage	274
	U2	●	Power supply insufficient or instantaneous abnormality	276
	U3	●	Check operation not executed	278
	U4	●	Transmission error between indoor units and outdoor units	279
	U5	●	Transmission error between remote controller and indoor unit	281
	U8	●	Transmission error between main and sub remote controllers	282
	U9	●	Transmission error between indoor units and outdoor units in the same system	283
	UA	●	Improper combination of indoor and outdoor units, indoor units and remote controller	284
			Incorrect gas furnace connecting number	286
			Incorrect electric heater capacity setting	287
	UC (*1)	○	Address duplication of centralized controller	288
	UE	●	Transmission error between centralized controller and indoor unit	289
	UF	●	System not set yet	292
	UH	●	System abnormality, refrigerant system address undefined	293
			Climate Talk communication system combination error (before initial setting for communication completes)	294
			Climate Talk communication system combination error (after initial setting for communication completes)	295
	M1	●	Defective PCB	296
	M8	●	Transmission error (between centralized controllers)	297
	MA	●	Poor centralized controller combination	299
	MC	●	Address duplication, poor setting	301
—	●	Operation lamp blinking	303	
—	●	Central control indicator lamp blinking (one blink)	305	
—	●	Central control indicator lamp blinking (two blinks)	308	



**Note(s)**

\*1 : The system can keep operating, however, be sure to check and repair.

\*2 : The system may or may not continue operation depending on the conditions.



## 5.2 Error Codes (Sub Codes)

If an error code like the one shown below is displayed when a wired remote controller is in use, make a detailed diagnosis.

### 5.2.1 Indoor Unit

Error code	Troubleshooting	
	Error Description	Diagnosis
A0 - 01	External protection device abnormality	Refer to page 205.
A6 - 01	Fan motor locked	A locked fan motor current has been detected. Turn the fan by hand to check for the connection of connectors.
A6 - 10	Fan overcurrent error	A fan motor overcurrent has been detected. Check for the connection of the connector between the fan motor and the fan PCB. If the connection is normal, replace the fan motor. If this still cannot solve the error, replace the fan PCB.
A6 - 11	Fan position detection error	An error in the detection of position of the fan motor. Check for the connection of the connector between the fan motor and the fan PCB. If the connection is normal, replace the fan motor. If this still cannot solve the error, replace the fan PCB.
A6 - 20	Indoor fan motor status abnormality	Refer to page 216.
A6 - 21	Low indoor airflow	Refer to page 217.
A8 - 01	Power supply voltage error	Check for the input voltage of the fan motor.
A9 - 01	Electronic expansion valve error	There is an error in the electronic expansion valve coil or a connector disconnected.
A9 - 02	Refrigerant leakage detection error	Refrigerant leaks even if the electronic expansion valve is closed. Replace the electronic expansion valve.
AA - 03	Gas furnace abnormality	Refer to page 223.
AH - 03	Transmission error (between the self-cleaning decoration panel and the indoor unit) (when the self-cleaning decoration panel is mounted)	Check for the connection of the harness connector between the panel PCB and the indoor unit PCB.
AH - 04	Dust detection sensor error (when the self-cleaning decoration panel is mounted)	Check for the connections of the connector X12A on the panel PCB and the connectors X18A and X19A on the sensor PCB.
AH - 05	Dust collection sign error (when the self-cleaning decoration panel is mounted)	Check for clogging with dust at the dust collection port as well as in the brush unit, S-shaped pipe, and dust box. Furthermore, check for any stains of the light receiving and emitting parts of the infrared unit.
AH - 06	Air filter rotation error (when the self-cleaning decoration panel is mounted)	Check for anything getting in the way of rotating the filter (e.g. the filter comes off or the drive gear is clogged with foreign matter).
AH - 07	Damper rotation error (when the self-cleaning decoration panel is mounted)	The damper does not rotate normally. Check for any foreign matter around the damper and for the operation of the gear and limit switch.
AH - 08	Filter self-cleaning operation error (when the self-cleaning decoration panel is mounted)	The unit has not yet completed the filter self-cleaning operation even after the lapse of specified period of time. Check for any external noise, etc.
AH - 09	Filter self-cleaning operation start disabled error (when the self-cleaning decoration panel is mounted)	The unit has been put into a state in which the filter self-cleaning operation is disabled. Check the unit for the operating conditions.
AJ - 01	Capacity setting error	There is an error in the capacity setting of the indoor unit PCB.
AJ - 02	Electronic expansion valve setting error	There is a fault in the setting of the gear type electronic expansion valve/direct acting type electronic expansion valve.
C1 - 01	Transmission abnormality between indoor unit PCB and fan PCB	Check for the conditions of transmission between the indoor unit PCB and the fan PCB.
C1 - 07	Blower motor communication error	Refer to page 239.
C1 - 08	Climate Talk Communication error	Refer to page 240.
C6 - 01	Defective combination of indoor unit PCB and the fan PCB	A combination of indoor unit PCB and the fan PCB is defective. Check whether the capacity setting adaptor is correct and the type of the fan PCB is correct.
	Blower motor HP mismatch	Refer to page 243.
C6 - 02	Indoor blower does not have required parameters to function	Refer to page 244.
U4 - 01	Indoor-outdoor transmission error	Refer to the <b>U4</b> flowchart.
UA - 13	Refrigerant type error	The type of refrigerant used for the indoor unit is different from that used for the outdoor unit.
UA - 15	Not applicable for self-cleaning decoration panel [when the self-cleaning decoration panel is mounted]	An outdoor unit is not applicable for the self-cleaning decoration panel is connected.
UA - 17	Incorrect electric heater capacity setting	Refer to page 287.

Error code	Troubleshooting	
	Error Description	Diagnosis
<b>UH - 05</b>	Climate Talk Communication system combination error (before initial setting for communication completes)	Refer to page 294.
<b>UH - 06</b>	Climate Talk Communication system combination error (after initial setting for communication completes)	Refer to page 295.

## 5.3 External Protection Device Abnormality

### 5.3.1 External Protection Device Abnormality (Except FXTQ-TA and CXTQ-TA)

<b>Applicable Models</b>	All indoor unit models (except FXTQ-TA and CXTQ-TA)
<b>Error Code</b>	<b>A0</b>
<b>Method of Error Detection</b>	Detects open or short circuit between external input terminals in indoor unit.
<b>Error Decision Conditions</b>	When an open circuit occurs between external input terminals with the remote controller set to "external ON/OFF terminal".
<b>Supposed Causes</b>	<ul style="list-style-type: none"> <li>■ Activation of external protection device</li> <li>■ Improper field setting</li> <li>■ Defective indoor unit control PCB</li> </ul>

#### Troubleshooting

**Caution**

Be sure to turn off the power switch before connecting or disconnecting connectors, or parts may be damaged.

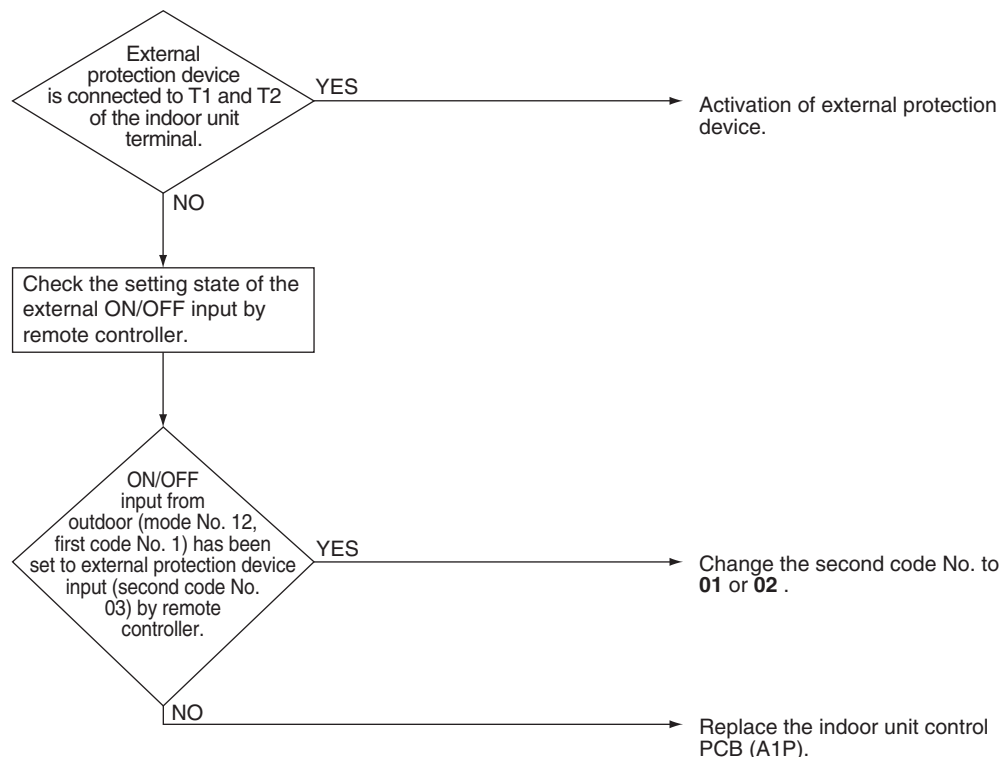

### 5.3.2 External Protection Device Abnormality (FXTQ-TA and CXTQ-TA Only)

**Applicable Models** FXTQ-TA, CXTQ-TA

**Error Code** **A0-01**

**Method of Error Detection** Detect open or short circuit between external input terminals in indoor unit.

**Error Decision Conditions** When an open circuit occurs between external input terminals.

- Supposed Causes**
- Activation of external protection device
  - Defective indoor unit PCB
  - Indoor unit fuse blown
  - 24 VAC power is not supplied to TH2 and TR2 terminals (FXTQ-TA) or R and C terminals (CXTQ-TA) on the indoor unit PCB.

**Troubleshooting**



**Caution**

Be sure to turn off the power switch before connecting or disconnecting connectors, or parts may be damaged.

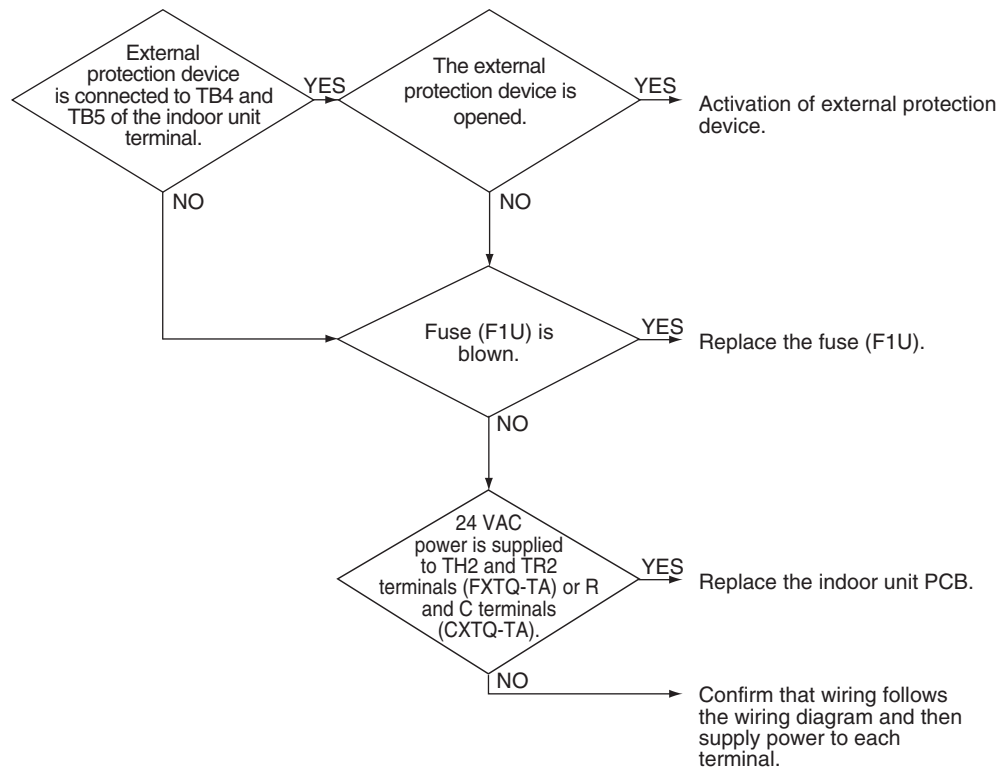

## 5.4 Indoor Unit Control PCB Abnormality

<b>Applicable Models</b>	All indoor unit models
<b>Error Code</b>	<b>A1</b>
<b>Method of Error Detection</b>	Check data from EEPROM.
<b>Error Decision Conditions</b>	When data could not be correctly received from the EEPROM EEPROM : Type of nonvolatile memory. Maintains memory contents even when the power supply is turned OFF.
<b>Supposed Causes</b>	<ul style="list-style-type: none"> <li>■ Defective indoor unit control PCB</li> <li>■ External factor (Noise, etc.)</li> </ul>
<b>Troubleshooting</b>	<div style="text-align: center;">  <p><b>Caution</b> Be sure to turn off the power switch before connecting or disconnecting connectors, or parts may be damaged.</p> </div> <pre> graph TD     Start[Turn the power supply OFF, then the power ON again.] --&gt; Decision{Does the system return to normal?}     Decision -- YES --&gt; Normal[The indoor unit control PCB (A1P) is normal. External factor other than error (for example, noise etc.).]     Decision -- NO --&gt; Replace[Replace the indoor unit control PCB (A1P).]           </pre>



**Caution**

Be sure to turn off the power switch before connecting or disconnecting connectors, or parts may be damaged.

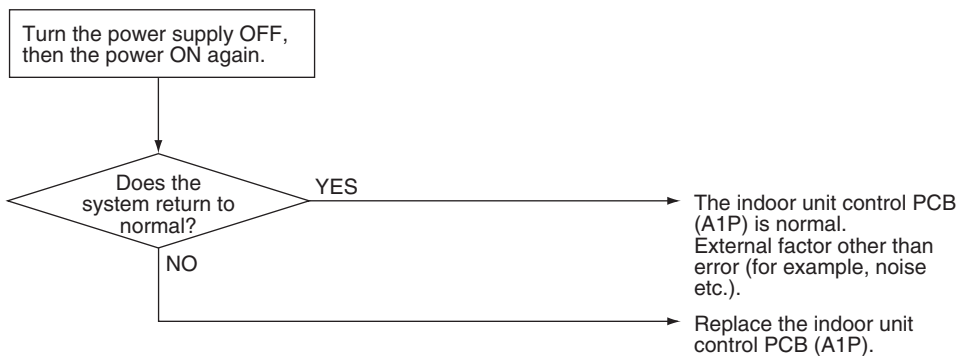

## 5.5 Drain Level Control System Abnormality

**Applicable Models** FXFQ-T, FXFQ-P, FXZQ-TA, FXZQ-TB, FXZQ-M, FXUQ-P, FXUQ-PA, FXEQ-P, FXDQ-M, FXSQ-TA, FXSQ-TB, FXMQ-PB, FXMQ-TB

**Error Code** **A3**

**Method of Error Detection** By float switch OFF detection

**Error Decision Conditions** When rise of water level is not a condition and the float switch goes OFF.

- Supposed Causes**
- 208-230 V power supply is not provided
  - Defective float switch or short circuit connector
  - Defective drain pump
  - Drain clogging, upward slope, etc.
  - Defective indoor unit control PCB
  - Loose connection of connector

### Troubleshooting



**Caution**

Be sure to turn off the power switch before connecting or disconnecting connectors, or parts may be damaged.

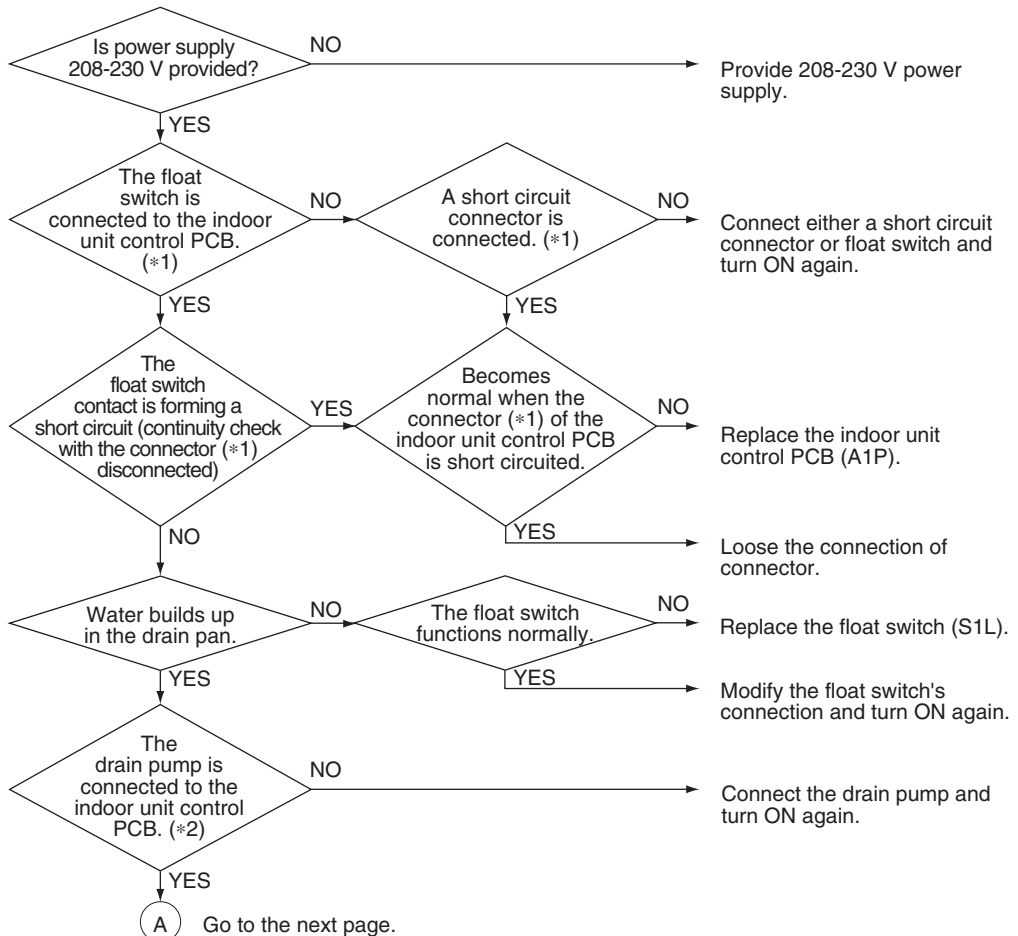

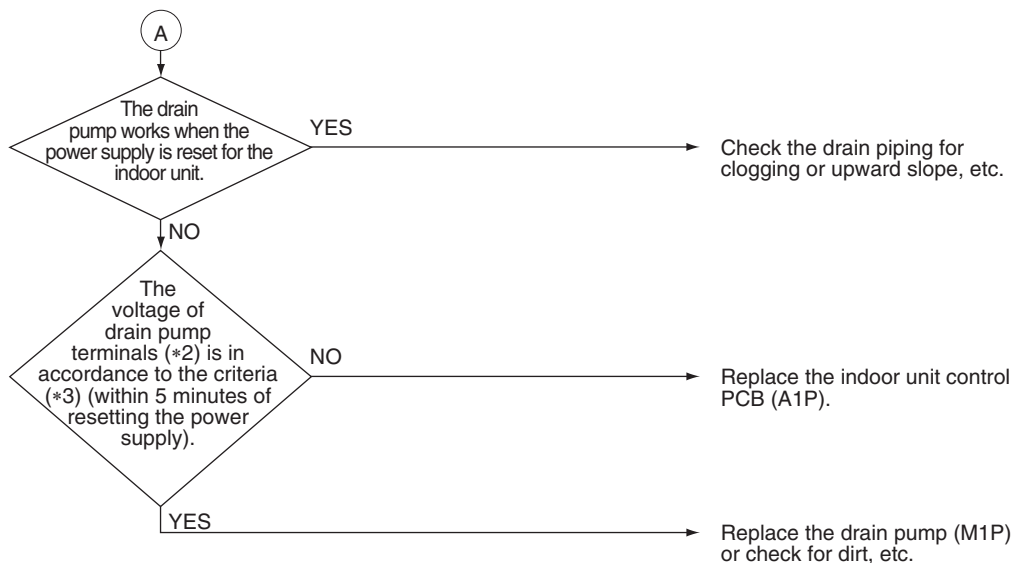

**i** Note(s)

Model	*1: Float switch (S1L) / short circuit connector	*2: Drain pump (M1P) connector	*3: Drain pump (M1P) voltage
FXFQ-T	X15A	X10A	13 VDC
FXFQ-P	X15A	X25A	220-240 VAC
FXZQ-TA	X15A	X102A	13 VDC
FXZQ-TB	X15A	X25A	13 VDC
FXZQ-M	X8A	X25A	220-240 VAC
FXUQ-P	X15A	X25A	13 VDC
FXUQ-PA	X15A	X25A	13 VDC
FXEQ-P	X15A	X25A	13 VDC
FXDQ-M	X8A	X25A	220-240 VAC
FXSQ-TA	X15A	X25A	13 VDC
FXSQ-TB	X15A	X25A	13 VDC
FXMQ-PB	X15A	X25A	220-240 VAC
FXMQ-TB	X15A	X25A	13 VDC

## 5.6 Indoor Fan Motor Lock, Overload

<b>Applicable Models</b>	FXFQ-T, FXFQ-P, FXZQ-TA, FXZQ-TB, FXUQ-P, FXUQ-PA, FXEQ-P, FXSQ05-48TA, FXSQ05-48TB, FXMQ07-12PB, FXMQ15-24TB, FXAQ-P
<b>Error Code</b>	<b>A6</b>
<b>Method of Error Detection</b>	Abnormal fan revolutions are detected by a signal output from the fan motor.
<b>Error Decision Conditions</b>	When the fan revolutions do not increase
<b>Supposed Causes</b>	<ul style="list-style-type: none"> <li>■ Broken wires in, short circuit of, or disconnection of connectors from the fan motor harness</li> <li>■ Defective fan motor (Broken wires or defective insulation)</li> <li>■ Abnormal signal output from the fan motor (defective circuit)</li> <li>■ Defective indoor unit control PCB</li> <li>■ Instantaneous disturbance in the power supply voltage</li> <li>■ Fan motor lock (Due to motor or external causes)</li> <li>■ The fan does not rotate due to foreign matter blocking the fan.</li> <li>■ Disconnection of the connector between the high-power PCB (A1P) and the low-power PCB (A2P) (FXSQ05-48TA, FXSQ05-48TB, FXMQ07-12PB, FXMQ15-24TB only)</li> <li>■ Blowout of the fuse connected between the indoor unit PCB and the fan motor harness</li> </ul>



## Troubleshooting



**Caution** Be sure to turn off the power switch before connecting or disconnecting connectors, or parts may be damaged.

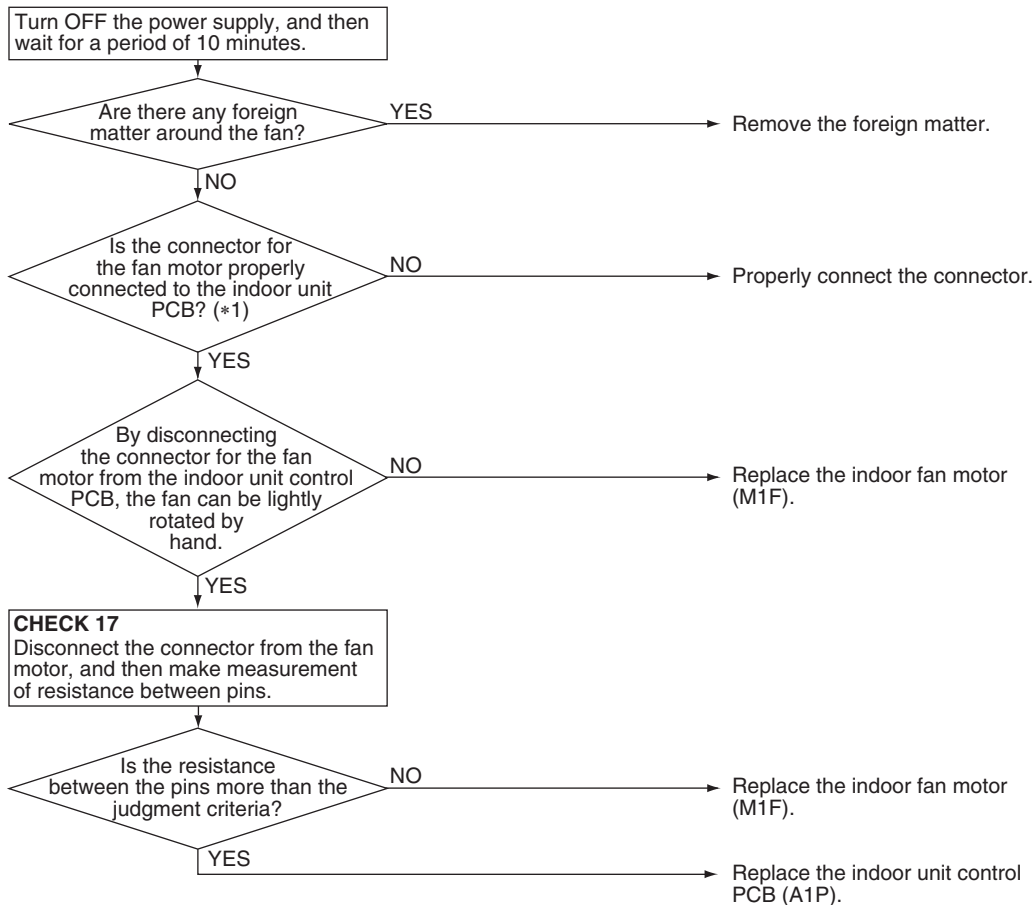

### Note(s)

\*1: Check the following connectors.

Model	Connector	PCB
FXFQ-T	X20A, Relay connector	A1P
FXFQ09-30P	X20A, Relay connector	A1P
FXFQ36/48P	X20A	A1P
FXZQ-TA	X20A, Relay connector	A1P
FXZQ-TB	X20A, Relay connector	A1P
FXUQ-P	X20A, Relay connector	A1P
FXUQ-PA	X20A, Relay connector	A1P
FXEQ-P	X20A	A1P
FXSQ05-48TA	X8A	A2P
FXSQ05-48TB	X8A	A2P
FXMQ07-12PB	X8A	A2P
FXMQ15-24TB	X8A	A2P
FXAQ-P	X20A	A1P



### Reference

**CHECK 17** Refer to page 327.

## 5.7 Indoor Fan Motor Abnormality

### 5.7.1 Indoor Fan Motor Abnormality (FXDQ-M, FXHQ-M Models)

**Applicable Models** FXDQ-M, FXHQ-M

**Error Code** **A6**

**Method of Error Detection** This error is detected if there is no revolution detection signal output from the fan motor.

**Error Decision Conditions** When no revolutions can be detected even at the maximum output voltage to the fan

- Supposed Causes**
- Defective indoor fan motor
  - Broken wires
  - Defective contact

#### Troubleshooting



**Caution**

Be sure to turn off the power switch before connecting or disconnecting connectors, or parts may be damaged.

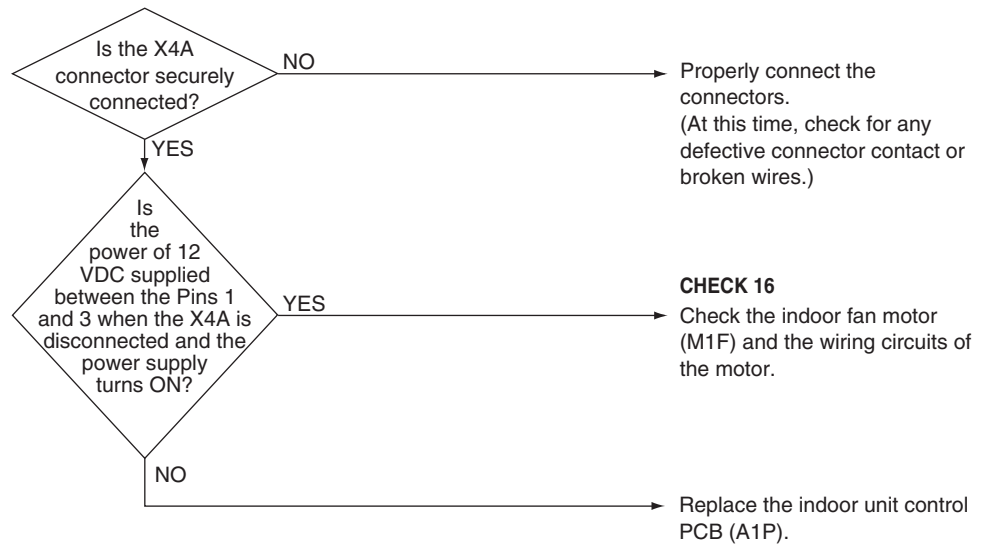

**Reference**

**CHECK 16** Refer to page 326.

## 5.7.2 Indoor Fan Motor Abnormality (FXSQ54TA, FXSQ54TB, FXMQ15-54PB, FXMQ30-54TB Models)

<b>Applicable Models</b>	FXSQ54TA, FXSQ54TB, FXMQ15-54PB, FXMQ30-54TB
<b>Error Code</b>	<b>A6</b>
<b>Method of Error Detection</b>	Error from the current flow on the fan PCB Error from the rotation speed of the fan motor in operation Error from the position signal of the fan motor Error from the current flow on the fan PCB when the fan motor starting operation
<b>Error Decision Conditions</b>	<ul style="list-style-type: none"> <li>■ An overcurrent flows.</li> <li>■ The rotation speed is less than a certain level for 6 seconds.</li> <li>■ A position error in the fan rotor continues for 5 seconds or more.</li> </ul>
<b>Supposed Causes</b>	<ul style="list-style-type: none"> <li>■ Clogging of a foreign matter</li> <li>■ Disconnection of the fan motor connectors (X1A and X2A)</li> <li>■ Disconnection of the connectors between the indoor unit control PCB (A1P) and fan PCB (A2P)</li> <li>■ Defective fan PCB (A2P)</li> <li>■ Defective fan motor</li> </ul>

Troubleshooting



**Caution**

Be sure to turn off the power switch before connecting or disconnecting connectors, or parts may be damaged.

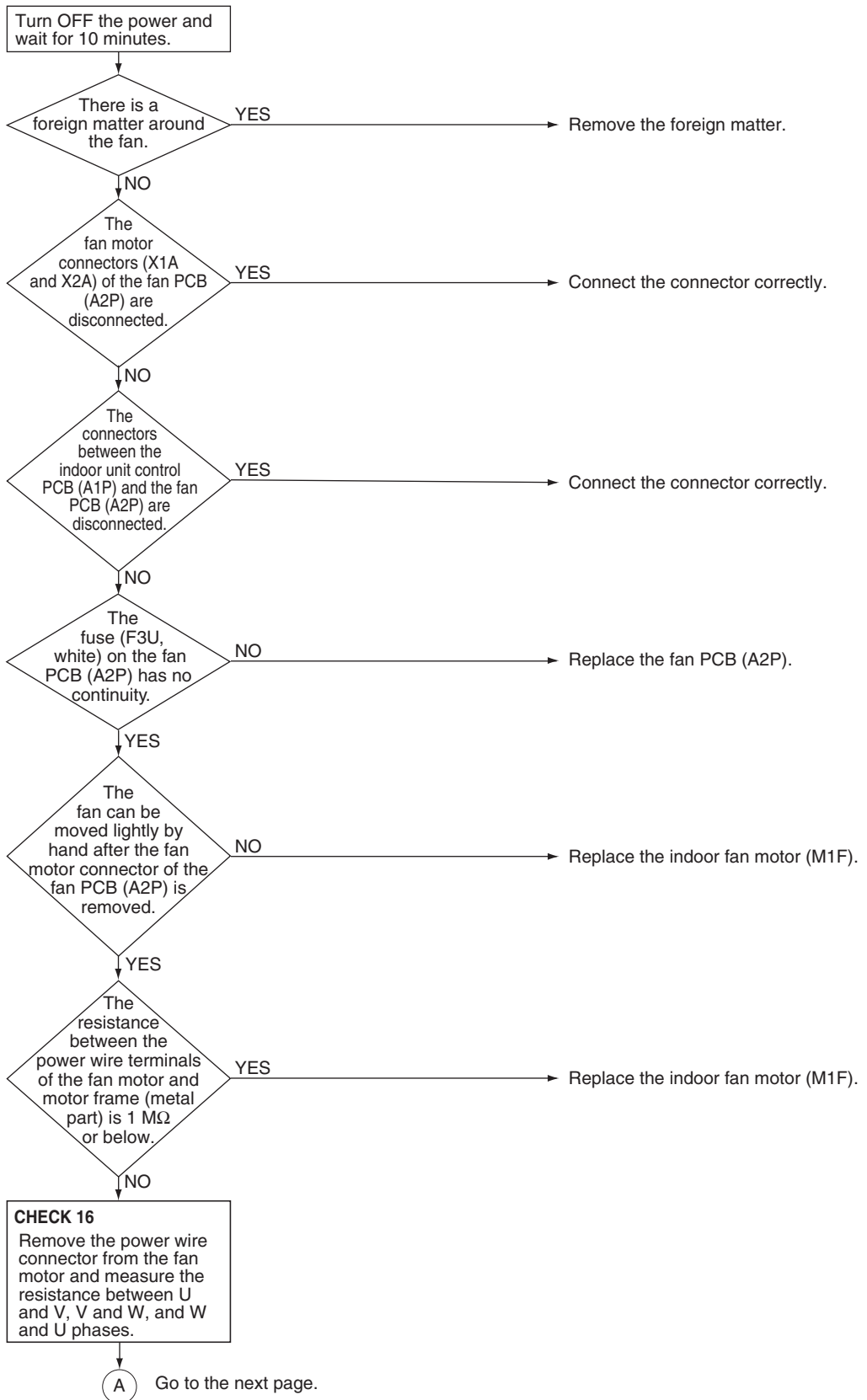

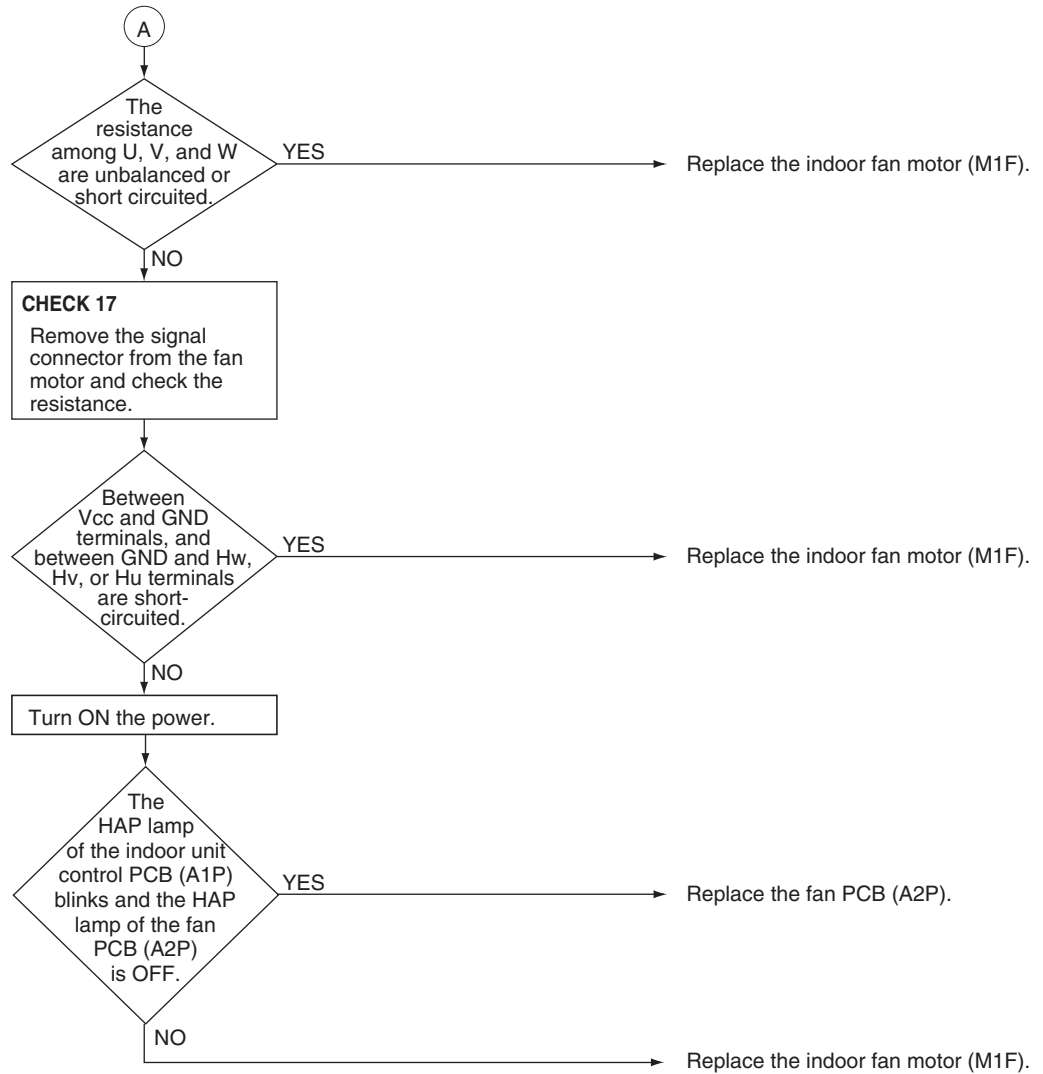

Reference **CHECK 16** Refer to page 326.



Reference **CHECK 17** Refer to page 327.

## 5.8 Blower Motor Not Running

**Applicable Models**

FXTQ-TA

**Error Code**

**A6**

**Outline**

Error is issued if the indoor unit determines that the indoor fan motor cannot rotate.

**Error Decision Conditions**

- **Determining successive abnormalities**  
 Checks the rotation speed at 5-second intervals using the feedback of the fan motor. If that figure falls below 50 rpm 5 times successively, it is deemed abnormal operation. If, during operation, the rotation command is stopped, the 5-second interval check is halted and the counted number will be cleared.
  
- **Determining long-term abnormalities**  
 Checks the rotation speed at 5-second intervals using the feedback of the fan motor. Performs rotation sampling 720 times (takes approximately one hour), and if the rotation speed falls below 50 rpm over 100 times, it is deemed abnormal operation. When the sampling reaches 720 times, the counted number will be cleared and the 720 times sampling restarts. If, during this, the rotation command is stopped, the 5-second interval check is halted, but the counted number will be kept. When the rotation command is restarted, the checks will resume.

**Error Reset Conditions**

Reset by remote controller

**Supposed Causes**

- Fan or motor obstruction
- Power interruption (low voltage)
- Incorrect or loose wiring

**Corrective Actions**

- Check for obstruction on the fan or motor.
- Verify the input voltage at the motor.
- Check wiring or tighten wiring connections if needed.
- Replace the indoor unit control PCB or motor.



Reference

**CHECK 19** Refer to page 331.

## 5.9 Indoor Fan Motor Status Abnormality

### Applicable Models

FXTQ-TA

### Error Code

**A6-20**

### Outline

The indoor unit periodically receives control status information from the fan motor. Error is issued when the information shows abnormality.

### Error Decision Conditions

If the information shows Power Limit or Temp Limit status, it will be deemed a MOTOR LIMIT abnormal operation. (The system can keep operating.)  
If the information shows Motor Lost Control or Current Trip status, it will be deemed a MOTOR TRIP abnormal operation. (The system stops operating.)

### Error Reset Conditions

If the indoor unit stops receiving abnormal information, the error will be cleared.

### Supposed Causes

- Fan or motor obstruction
- Blocked filters
- Power interruption (low voltage)
- Incorrect wiring
- Blockage in the airflow (ductwork) or ductwork undersized
- High loading conditions

### Corrective Actions

- Check for obstruction on the fan, motor, or ductwork.
- Clean filters.
- Check filters, grille, duct system, heat exchanger air inlet/outlet for blockages.
- Verify the input voltage at the motor.
- Check wiring.
- Replace motor.



Reference

**CHECK 19** Refer to page 331.

## 5.10 Low Indoor Airflow

**Applicable Models**

FXTQ-TA

**Error Code**

**A6-21**

**Outline**

Error is issued if the indoor unit determines that the indoor fan motor rotation is insufficient, regardless of the rotation command from indoor unit.

**Error Decision Conditions**

- Determining successive abnormalities  
Checks the rotation speed at 5-second intervals using the feedback of the fan motor. If that figure exceeds 50 rpm and falls below 150 rpm 10 times successively, it is deemed abnormal operation.  
If, during operation, the rotation command is stopped, the 5-second interval check is halted and the counted number will be cleared.
- Determining long-term abnormalities  
Checks the rotation speed at 5-second intervals using the feedback of the fan motor. Performs rotation sampling 720 times (takes approximately one hour), and if the rotation speed exceeds 50 rpm and falls below 150 rpm over 360 times, it is deemed abnormal operation. When the counter reaches 720 times, the counted number will be cleared and the 720 times sampling restarts.  
If, during this, the rotation command is stopped, the 5-second interval check is halted, but the counted number will be kept.  
When the rotation command is restarted, the checks will resume.

**Error Reset Conditions**

- Determining successive abnormalities  
Checks the rotation speed at 5-second intervals using the feedback of the fan motor. If that figure exceeds 150 rpm even once, the error will be cleared.
- Determining long-term abnormalities  
Checks the rotation speed at 5-second intervals using the feedback of the fan motor. If that figure exceeds 150 rpm 36 times successively, the error will be cleared. At that point, the counted number and sampling number will be cleared, and the 720 times sampling starts again from the beginning.

**Supposed Causes**

- Fan or motor obstruction
- Blocked filters
- Restrictive ductwork or ductwork undersized
- Wiring disconnected
- Wrong outdoor and indoor combination
- Indoor fan motor failure

**Corrective Actions**

- Check for obstruction on the fan or motor.
- Check ductwork and filter for blockage.
- Clean filters.
- Remove obstruction. Verify all registers are fully open.
- Check the connections and the rotation of the motor.
- Verify the input voltage at the motor.
- Verify ductwork is appropriately sized for system. Resize or replace ductwork if needed.
- Replace motor.



Reference

**CHECK 19** Refer to page 331.



## 5.11 Swing Flap Motor Abnormality

**Applicable Models** FXHQ-M, FXAQ-P

**Error Code** **A7**

**Method of Error Detection** Utilizes ON/OFF of the limit switch when the motor turns.

**Error Decision Conditions** When ON/OFF of the micro-switch for positioning cannot be reversed even though the swing flap motor is energized for a specified amount of time (about 30 seconds).  
\* Error code is displayed but the system operates continuously.

**Supposed Causes**

- Defective swing motor
- Defective connection cable (power supply and limit switch)
- Defective airflow direction adjusting flap-cam
- Defective indoor unit control PCB

### Troubleshooting



**Caution**

Be sure to turn off the power switch before connecting or disconnecting connectors, or parts may be damaged.

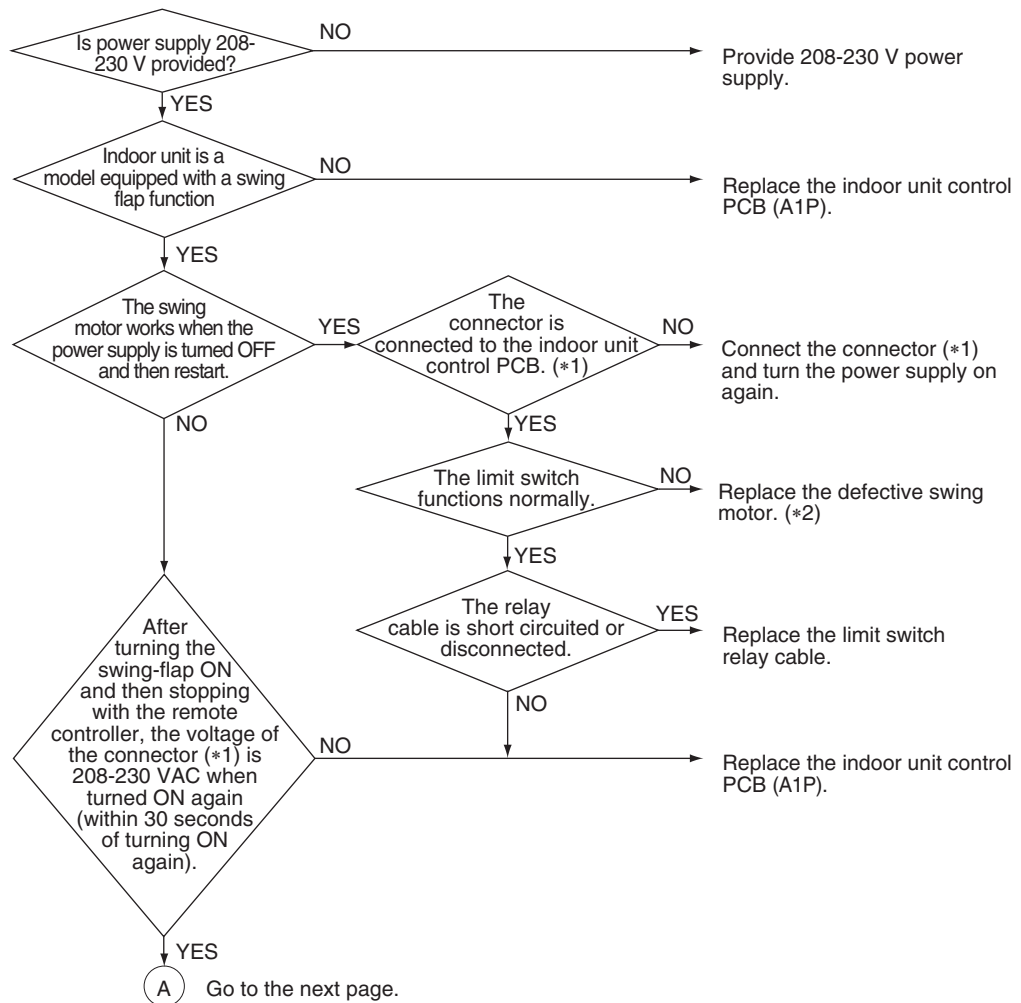

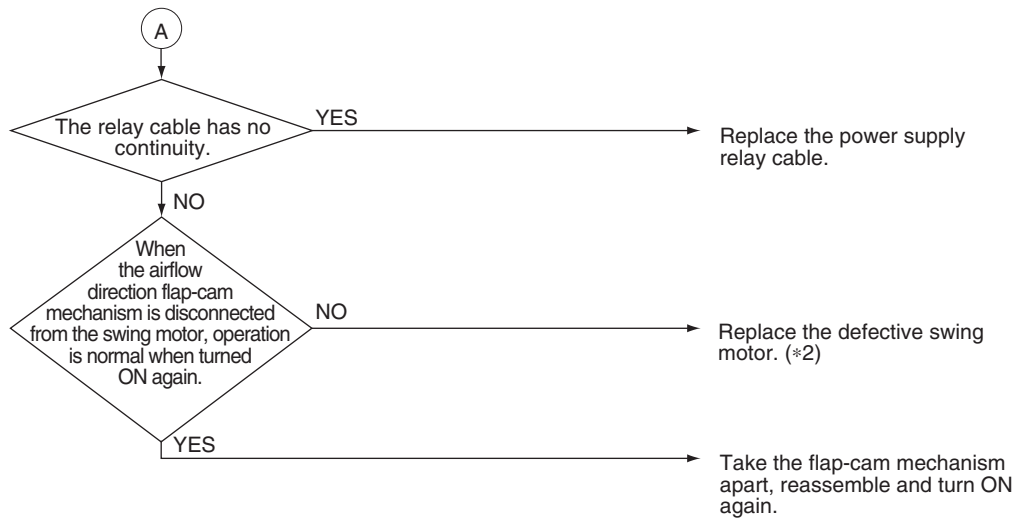

Model	*1: Swing motor connector	*2: Swing motor
FXHQ-M	X6A	M1S
FXAQ-P	X36A	M1S

## 5.12 Power Supply Voltage Abnormality

**Applicable Models** FXSQ-TA, FXSQ-TB, FXMQ-PB, FXMQ-TB

**Error Code** **A8**

**Method of Error Detection** Error is detected by checking the input voltage of the fan motor.

**Error Decision Conditions** When the input voltage of fan motor is 150 V or less, or 386 V or more.

**Supposed Causes**

- Defective power supply voltage
- Defective connection on signal line
- Defective wiring
- Instantaneous power failure, others

### Troubleshooting



**Caution**

Be sure to turn off the power switch before connecting or disconnecting connectors, or parts may be damaged.

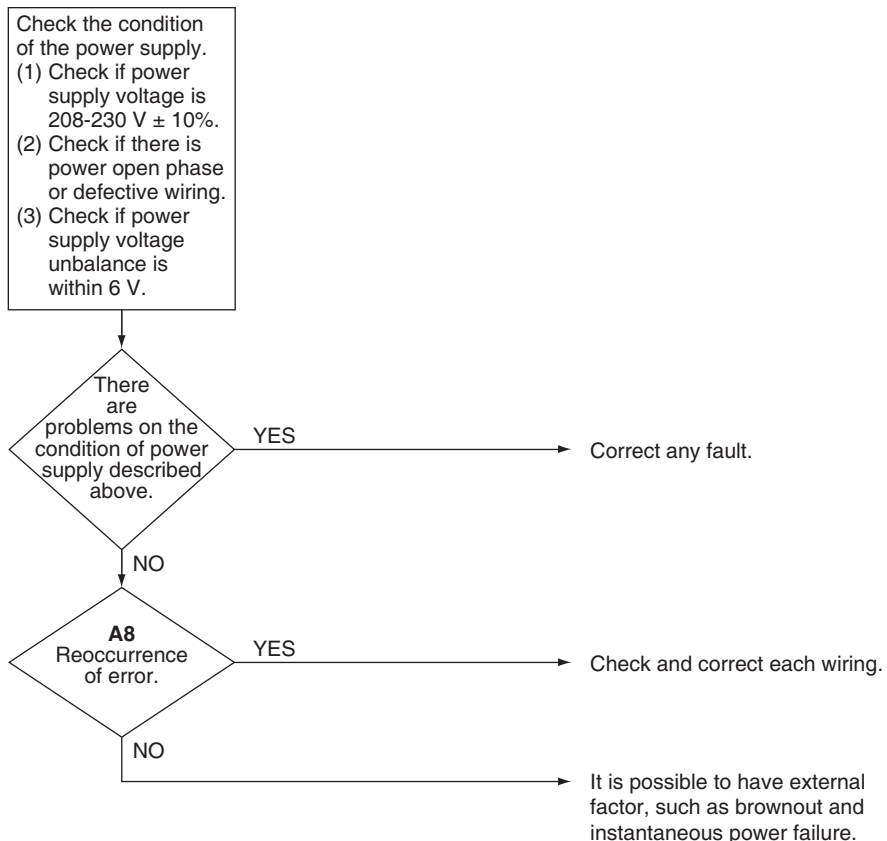

## 5.13 Blower Motor Stops for Over/Under Voltage

<b>Applicable Models</b>	FXTQ-TA
<b>Error Code</b>	<b>A8</b>
<b>Outline</b>	The indoor unit periodically receives control status information from the fan motor. Error is issued when the information shows abnormality.
<b>Error Decision Conditions</b>	If the information shows Over/Under Voltage status, it will be deemed a MOTOR VOLTS abnormal operation.
<b>Error Reset Conditions</b>	Reset by remote controller
<b>Supposed Causes</b>	<ul style="list-style-type: none"> <li>■ High AC line voltage to indoor blower motor</li> <li>■ Low AC line voltage to indoor blower motor</li> <li>■ Incorrect wiring</li> </ul>
<b>Corrective Actions</b>	<ul style="list-style-type: none"> <li>■ Verify line voltage to indoor blower motor is within the range specified on the ID blower rating plate.</li> <li>■ Check power to indoor blower motor.</li> <li>■ Check wiring.</li> <li>■ Replace motor.</li> </ul>

## 5.14 Electronic Expansion Valve Coil Abnormality, Dust Clogging

<b>Applicable Models</b>	All indoor unit models
<b>Error Code</b>	<b>A9</b>
<b>Method of Error Detection</b>	Check coil condition of electronic expansion valve by using microcomputer. Check dust clogging condition of electronic expansion valve main body by using microcomputer.
<b>Error Decision Conditions</b>	Pin input for electronic expansion valve coil is abnormal when initializing microcomputer. Either of the following conditions is seen/caused/occurs while the unit stops operation. <ul style="list-style-type: none"> <li>● R1T – R2T &gt; 8°C (14.4°F)</li> <li>● R2T shows fixed degrees or below.</li> </ul> R1T: temperature of suction air R2T: temperature of liquid pipe of heat exchanger
<b>Supposed Causes</b>	<ul style="list-style-type: none"> <li>■ Defective electronic expansion valve coil</li> <li>■ Defective indoor unit control PCB</li> <li>■ Defective relay cables</li> </ul>

### Troubleshooting

**Caution**

Be sure to turn off the power switch before connecting or disconnecting connectors, or parts may be damaged.

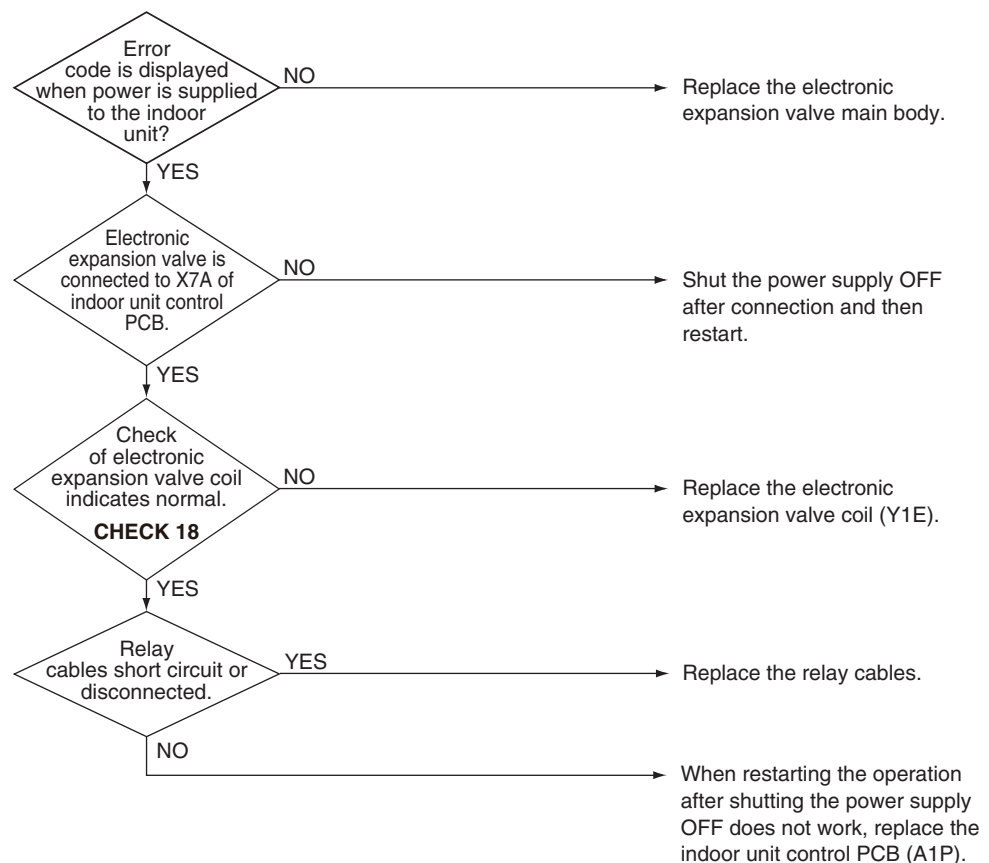
**Reference**
**CHECK 18** Refer to page 329.

## 5.15 Gas Furnace Abnormality

<b>Applicable Models</b>	CXTQ-TA
<b>Error Code</b>	<b>AA-03</b>
<b>Method of Error Detection</b>	Detects the error signal from the gas furnace when any error occurs on the gas furnace. The indoor unit displays <b>AA-03</b> for any sort of gas furnace abnormality.
<b>Error Decision Conditions</b>	The error status differs depending on each error code of the gas furnace. Refer to the gas furnace manual for details.
<b>Supposed Causes</b>	The cause of the error differs depending on each error code of the gas furnace. Refer to the gas furnace manual for details.
<b>Troubleshooting</b>	



**Caution**

Be sure to turn off the power switch before connecting or disconnecting connectors, or parts may be damaged.

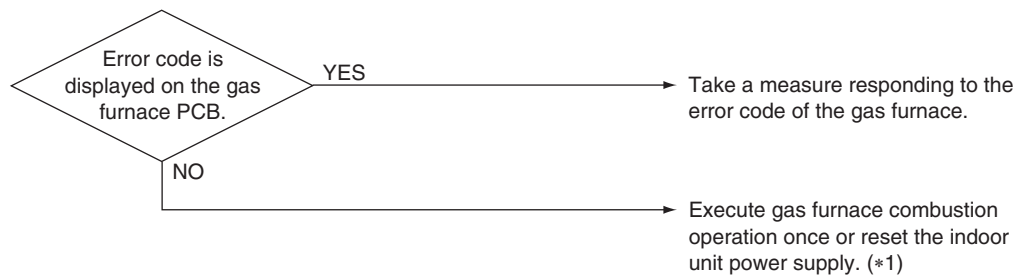

**Note(s)**

\*1. In some cases of gas furnace abnormality regarding gas combustion, once an error occurs, display indication of **AA-03** is retained even after the gas furnace recovered from the error to notify the occurrence of the error.  
The error indication disappears if you execute gas furnace combustion once or reset the indoor unit power supply.

## 5.16 Drain Level above Limit

<b>Applicable Models</b>	FXFQ-T, FXFQ-P, FXZQ-TA, FXZQ-TB, FXZQ-M, FXUQ-P, FXUQ-PA, FXEQ-P, FXDQ-M, FXSQ-TA, FXSQ-TB, FXMQ-PB, FXMQ-TB
<b>Error Code</b>	<b>AF</b>
<b>Method of Error Detection</b>	Water leakage is detected based on float switch ON/OFF operation while the compressor is not in operation.
<b>Error Decision Conditions</b>	When the float switch changes from ON to OFF while the compressor is not in operation. * Error code is displayed but the system operates continuously.
<b>Supposed Causes</b>	<ul style="list-style-type: none"> <li>■ Humidifier unit (optional accessory) leaking</li> <li>■ Defective drain pipe (upward slope, etc.)</li> <li>■ Defective indoor unit control PCB</li> </ul>
<b>Troubleshooting</b>	<div style="text-align: center;">  <p><b>Caution</b> Be sure to turn off the power switch before connecting or disconnecting connectors, or parts may be damaged.</p> </div> <pre> graph TD     A{Field drain piping has a defect such as upward sloping.} -- YES --&gt; B[Modify the drain piping.]     A -- NO --&gt; C{A humidifier unit (optional accessory) is installed on the indoor unit.}     C -- YES --&gt; D[Check if the humidifier unit is leaking.]     C -- NO --&gt; E[Defective indoor unit control PCB (A1P).]           </pre>



**Caution** Be sure to turn off the power switch before connecting or disconnecting connectors, or parts may be damaged.

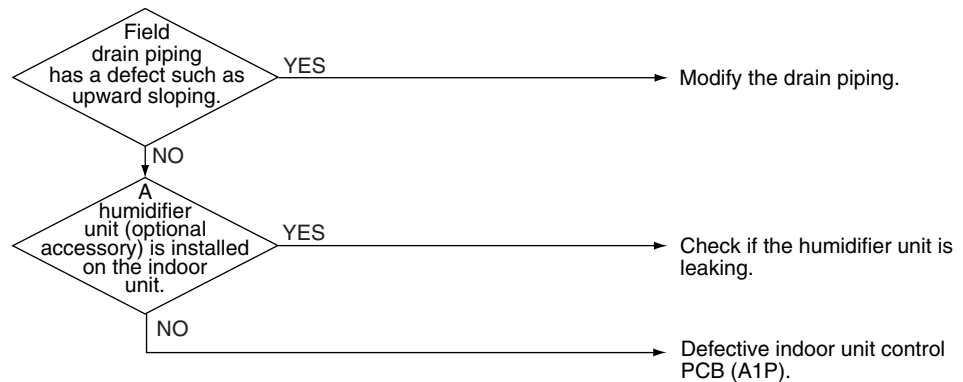

## 5.17 Self-Cleaning Decoration Panel Abnormality

<b>Applicable Models</b>	FXFQ-T (when self-cleaning decoration panel BYCQ125BGW1 is installed)
<b>Error Code</b>	<b>AH</b>
<b>Method of Error Detection</b>	Error is detected by abnormal signal from the self-cleaning decoration panel.
<b>Error Decision Conditions</b>	<p>Any of the following conditions is met while the unit is in operation.</p> <ul style="list-style-type: none"> <li>■ There is a transmission error between self-cleaning decoration panel and indoor unit.</li> <li>■ Dust detection sensor (light receiving side) is short-circuited.</li> <li>■ The total of fan operation time exceeds a specified value after dust collection sign display.</li> <li>■ Limit switch does not detect when air filter rotates or air filter does not rotate.</li> <li>■ Limit switch does not detect when damper opens (or closes) or damper does not work.</li> <li>■ Filter auto clean operation does not complete even after a specified time has elapsed.</li> <li>■ Filter auto clean operation does not start even after a specified time has elapsed.</li> </ul>
<b>Supposed Causes</b>	<ul style="list-style-type: none"> <li>■ Transmission error (between self-cleaning decoration panel and indoor unit)</li> <li>■ Dust detection sensor error</li> <li>■ Dust collection sign</li> <li>■ Air filter rotation error</li> <li>■ Damper rotation error</li> <li>■ Filter auto clean operation error</li> <li>■ Filter auto clean operation start disabled error</li> </ul>



## Troubleshooting



### Caution

Be sure to turn off the power switch before connecting or disconnecting connectors, or parts may be damaged.

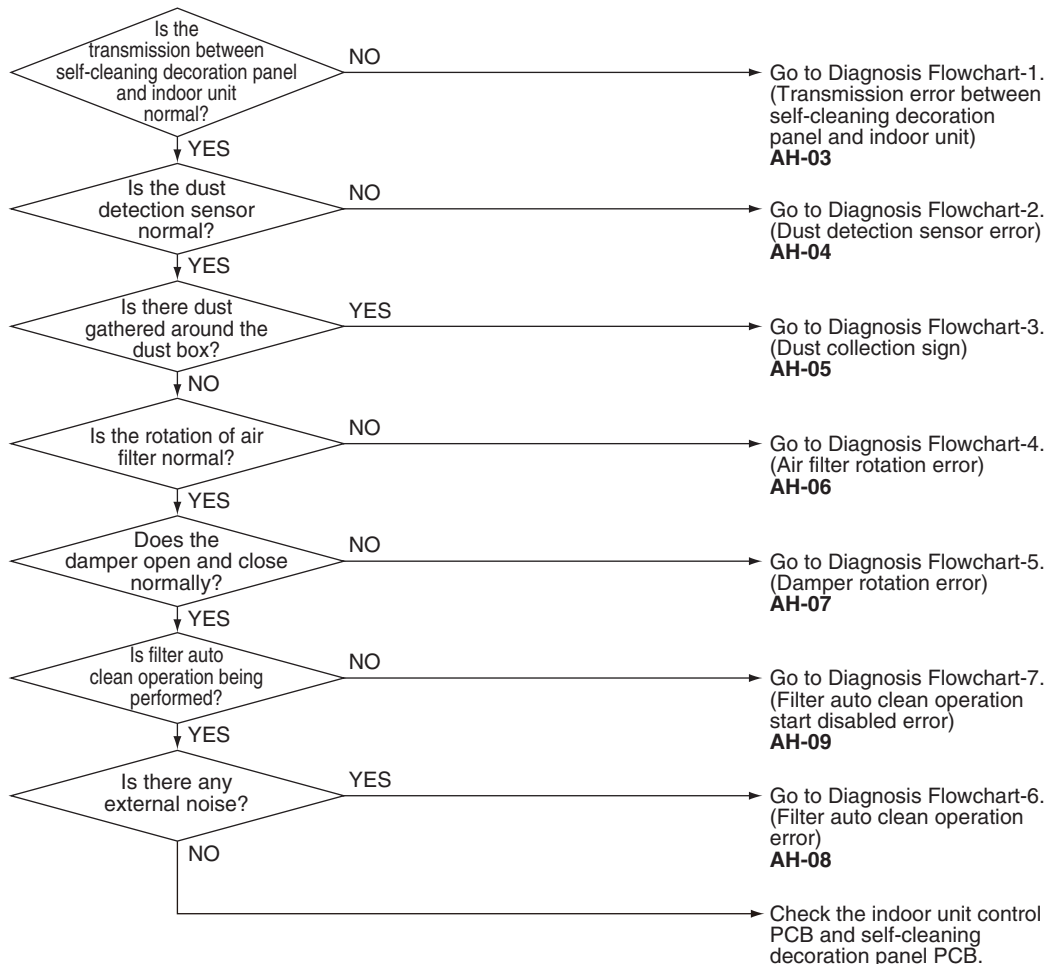

### Reference

Refer to the diagnosis flowchart below.

Error code	Diagnosis Flowchart
<b>AH-03</b>	Diagnosis Flowchart-1 on page 227
<b>AH-04</b>	Diagnosis Flowchart-2 on page 228
<b>AH-05</b>	Diagnosis Flowchart-3 on page 229
<b>AH-06</b>	Diagnosis Flowchart-4 on page 230
<b>AH-07</b>	Diagnosis Flowchart-5 on page 232
<b>AH-08</b>	Diagnosis Flowchart-6 on page 234
<b>AH-09</b>	Diagnosis Flowchart-7 on page 235



**Caution** Be sure to turn off the power switch before connecting or disconnecting connectors, or parts may be damaged.

Diagnosis Flowchart-1

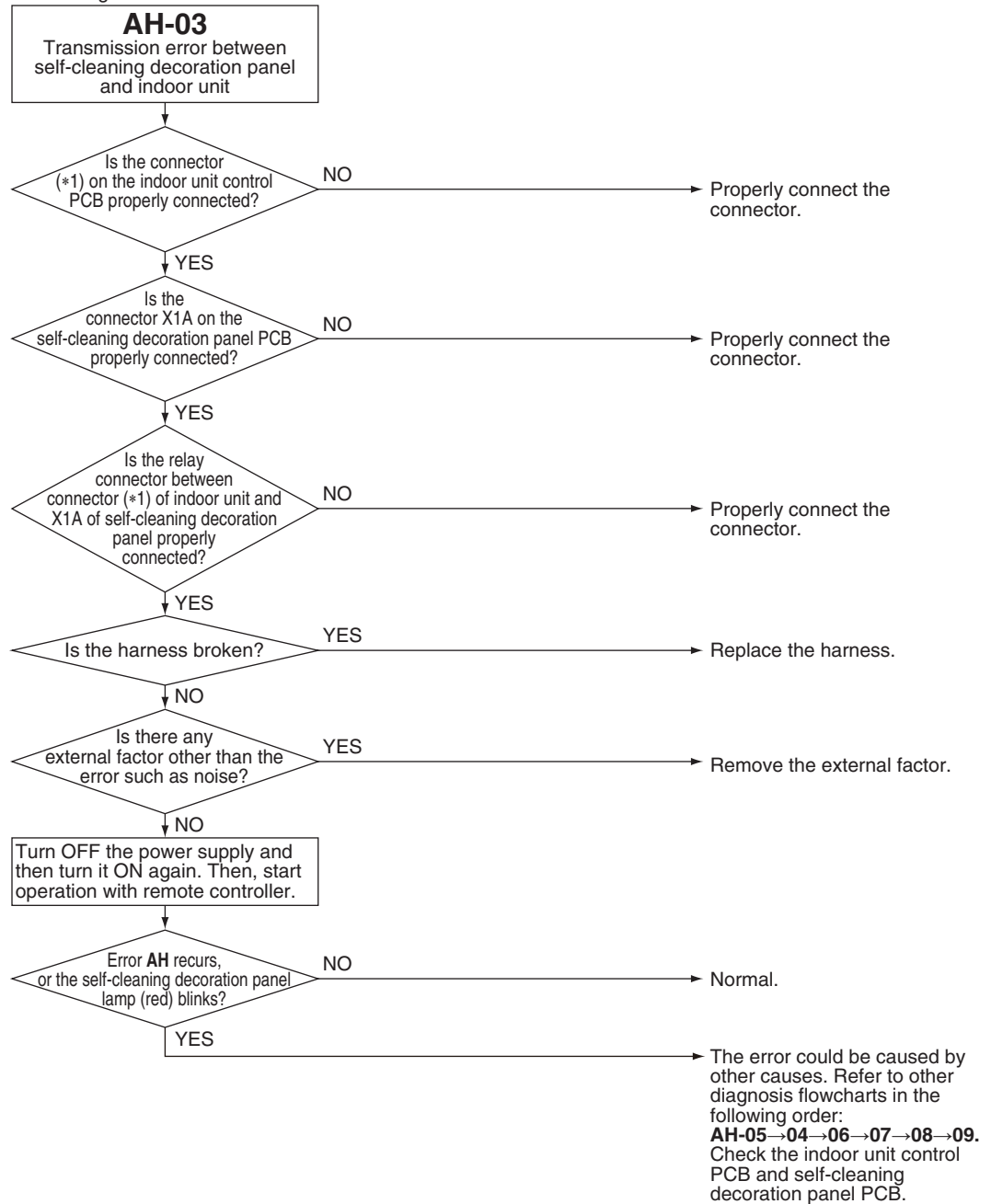

**Note(s)**

\*1. Connector

Model	Connector
FXFQ-T	X8A

**Caution**

Be sure to turn off the power switch before connecting or disconnecting connectors, or parts may be damaged.

## Diagnosis Flowchart-2

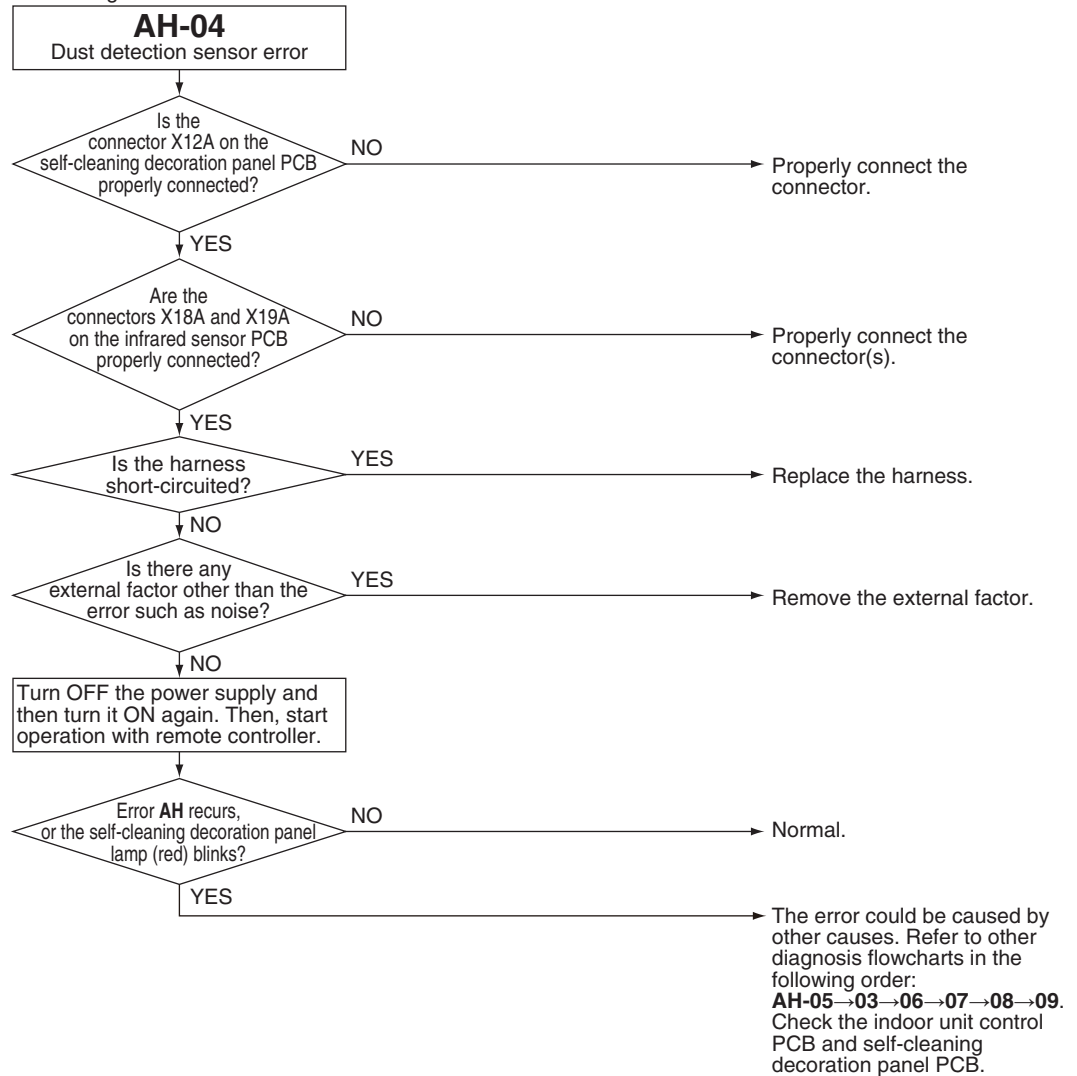



**Caution**

Be sure to turn off the power switch before connecting or disconnecting connectors, or parts may be damaged.

Diagnosis Flowchart-3

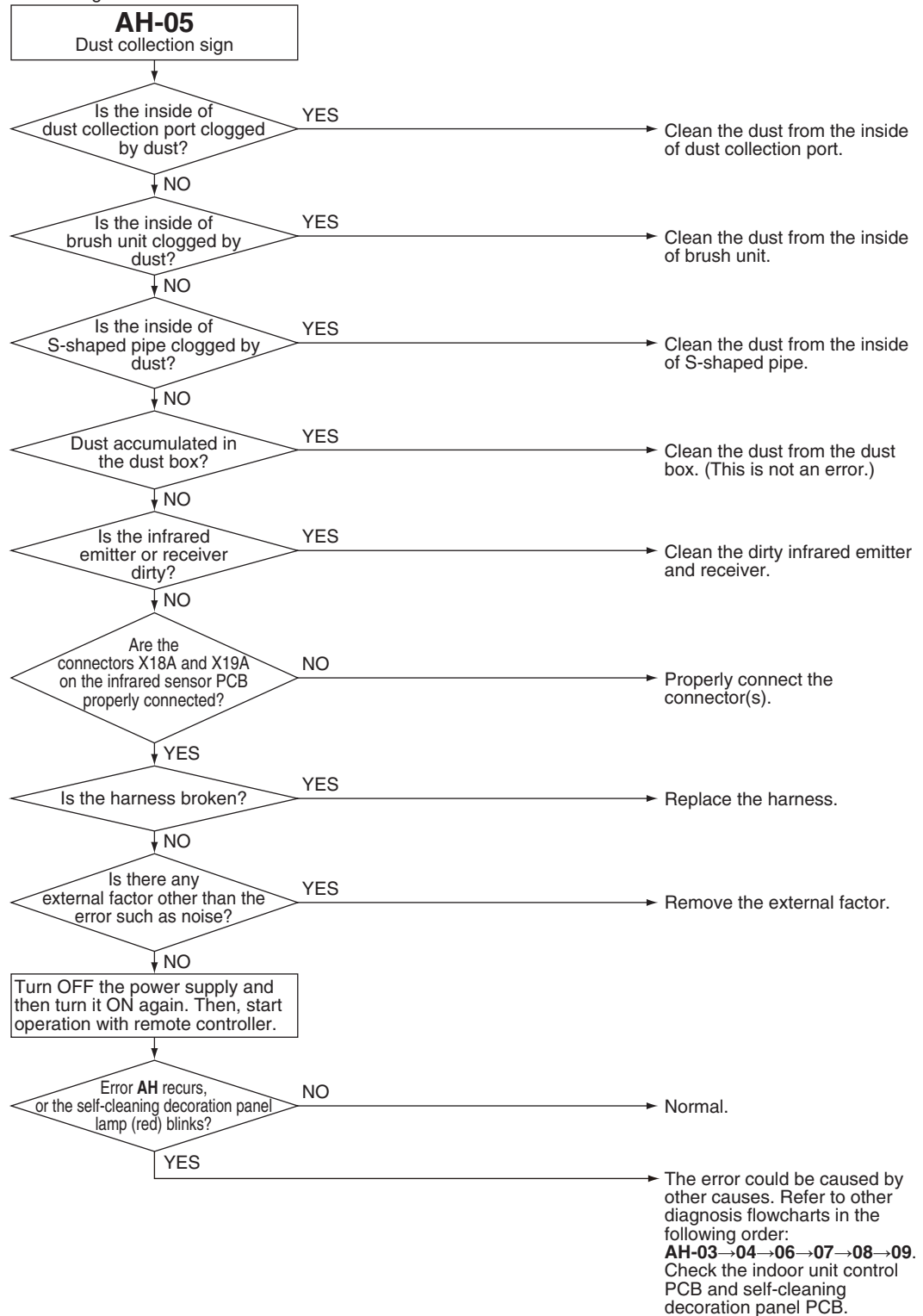

**Caution**

Be sure to turn off the power switch before connecting or disconnecting connectors, or parts may be damaged.

## Diagnosis Flowchart-4

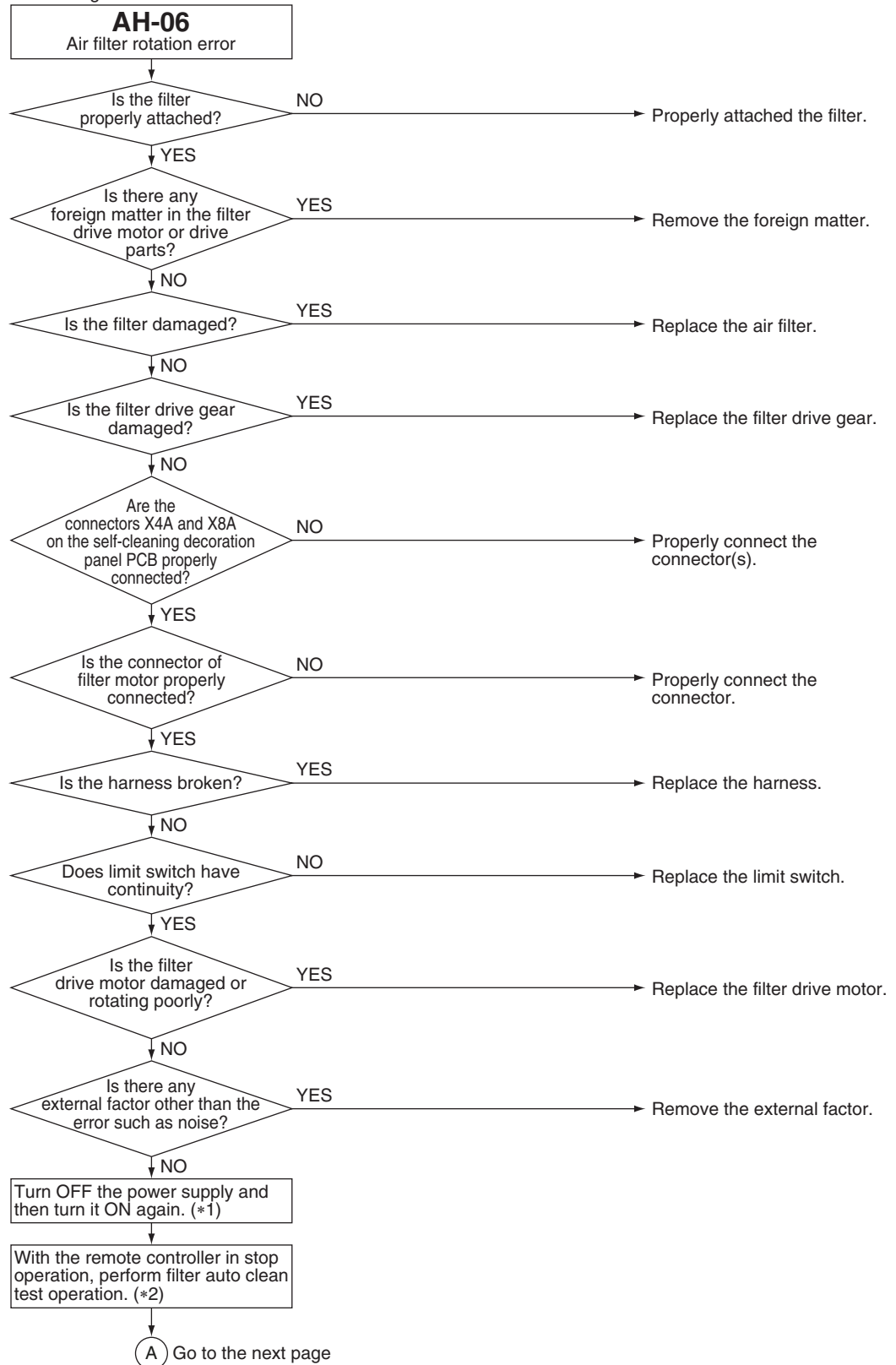

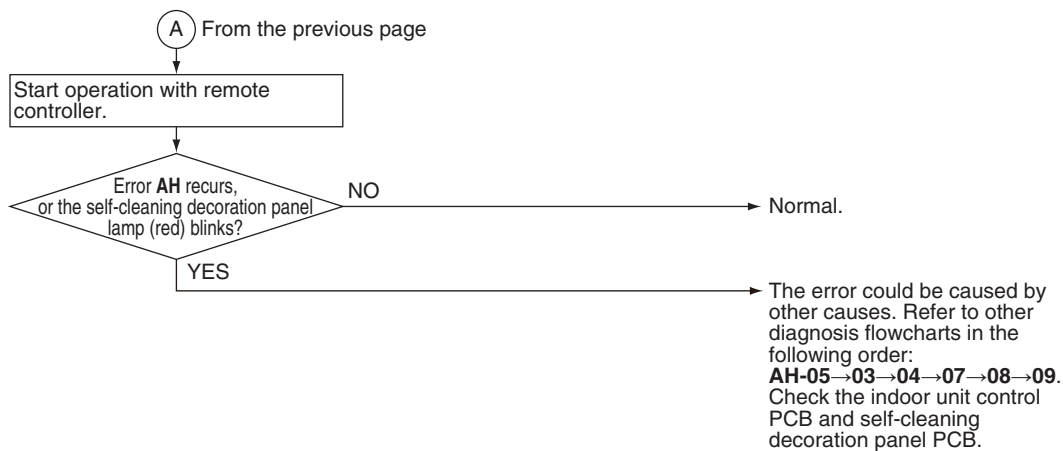

**i** Note(s)

\*1. Temporary error code reset operation can be performed by pressing the push switch button (BS2) on the self-cleaning decoration panel PCB

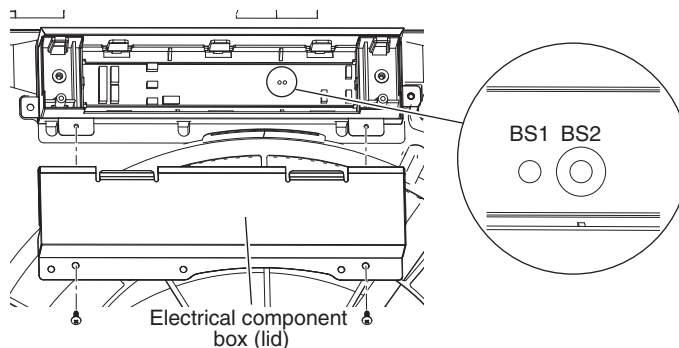

\*2. For details on performing filter auto clean test operation, refer to the operation manual of the self-cleaning decoration panel.

**Caution**

Be sure to turn off the power switch before connecting or disconnecting connectors, or parts may be damaged.

## Diagnosis Flowchart-5

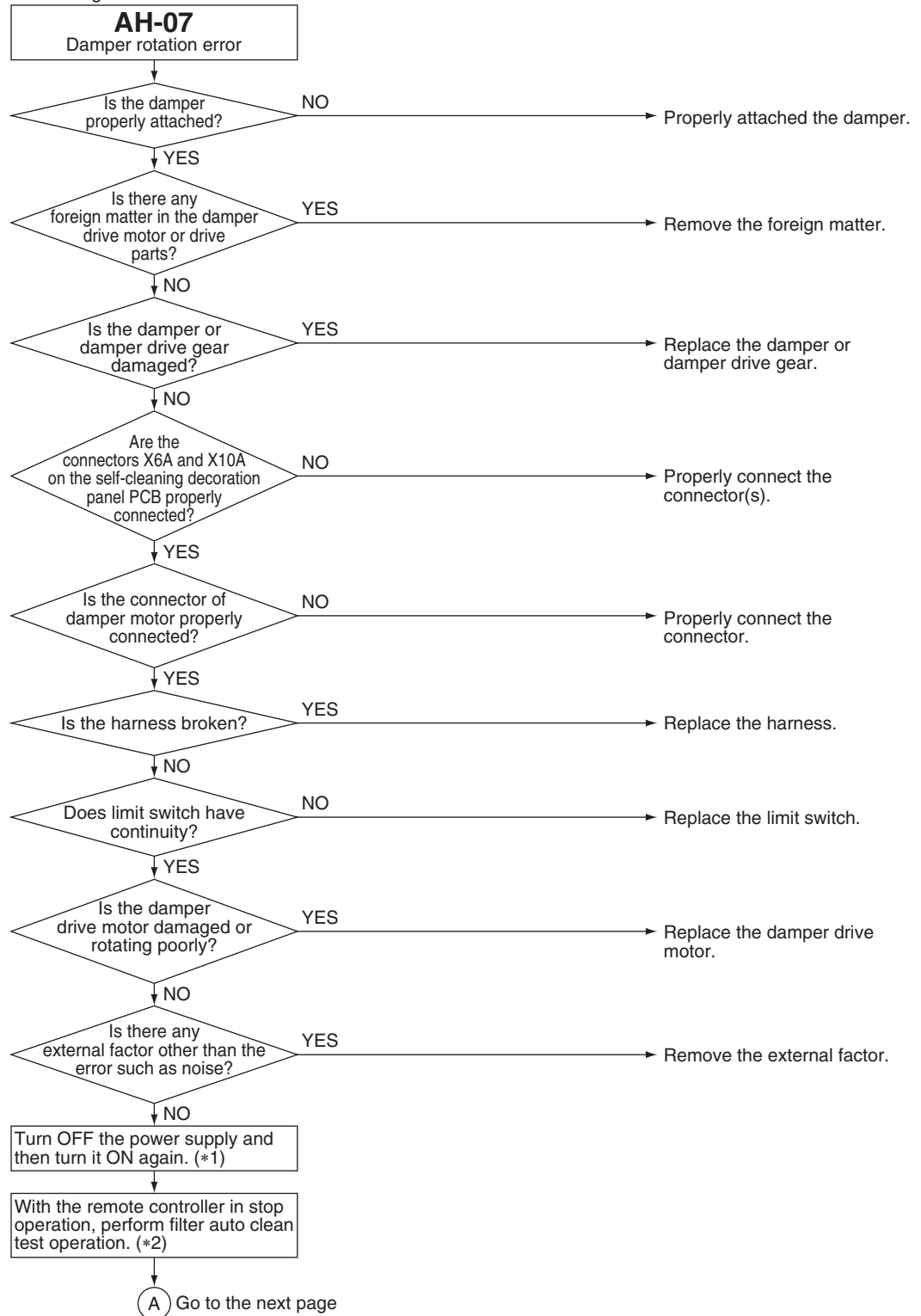

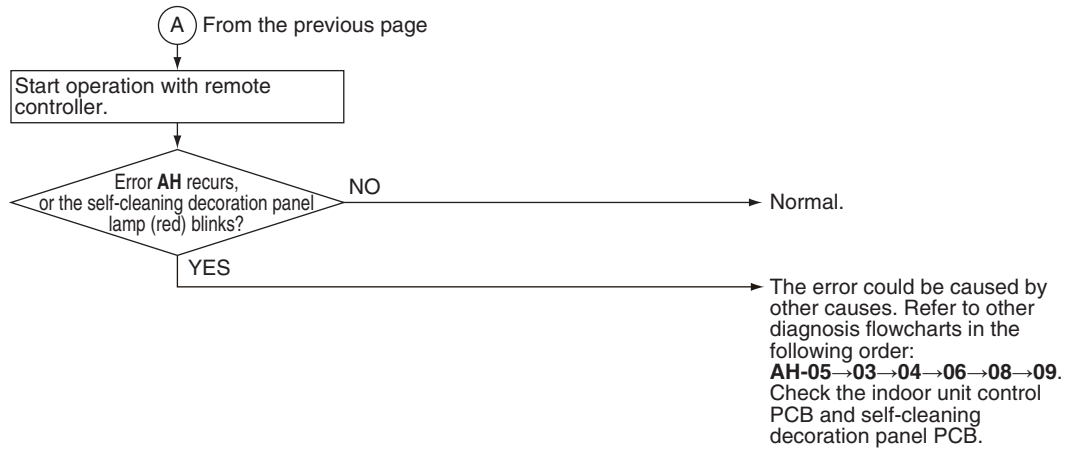

**i** Note(s)

\*1. Temporary error code reset operation can be performed by pressing the push switch button (BS2) on the self-cleaning decoration panel PCB

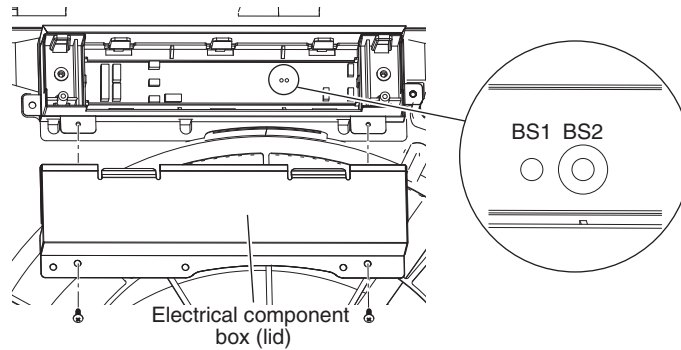

\*2. For details on performing filter auto clean test operation, refer to the operation manual of the self-cleaning decoration panel.



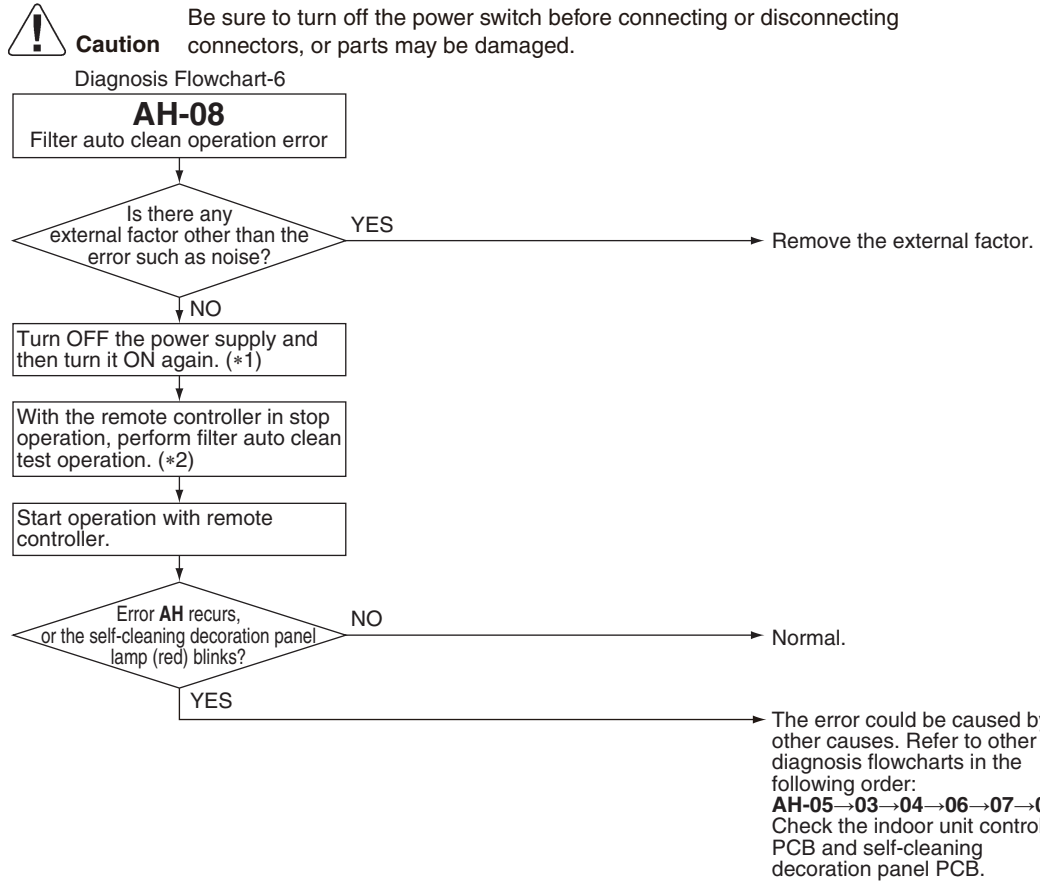

**i Note(s)**

\*1. Temporary error code reset operation can be performed by pressing the push switch button (BS2) on the self-cleaning decoration panel PCB

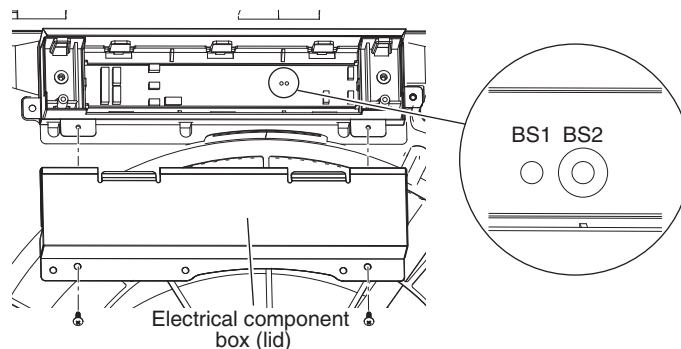

\*2. For details on performing filter auto clean test operation, refer to the operation manual of the self-cleaning decoration panel.

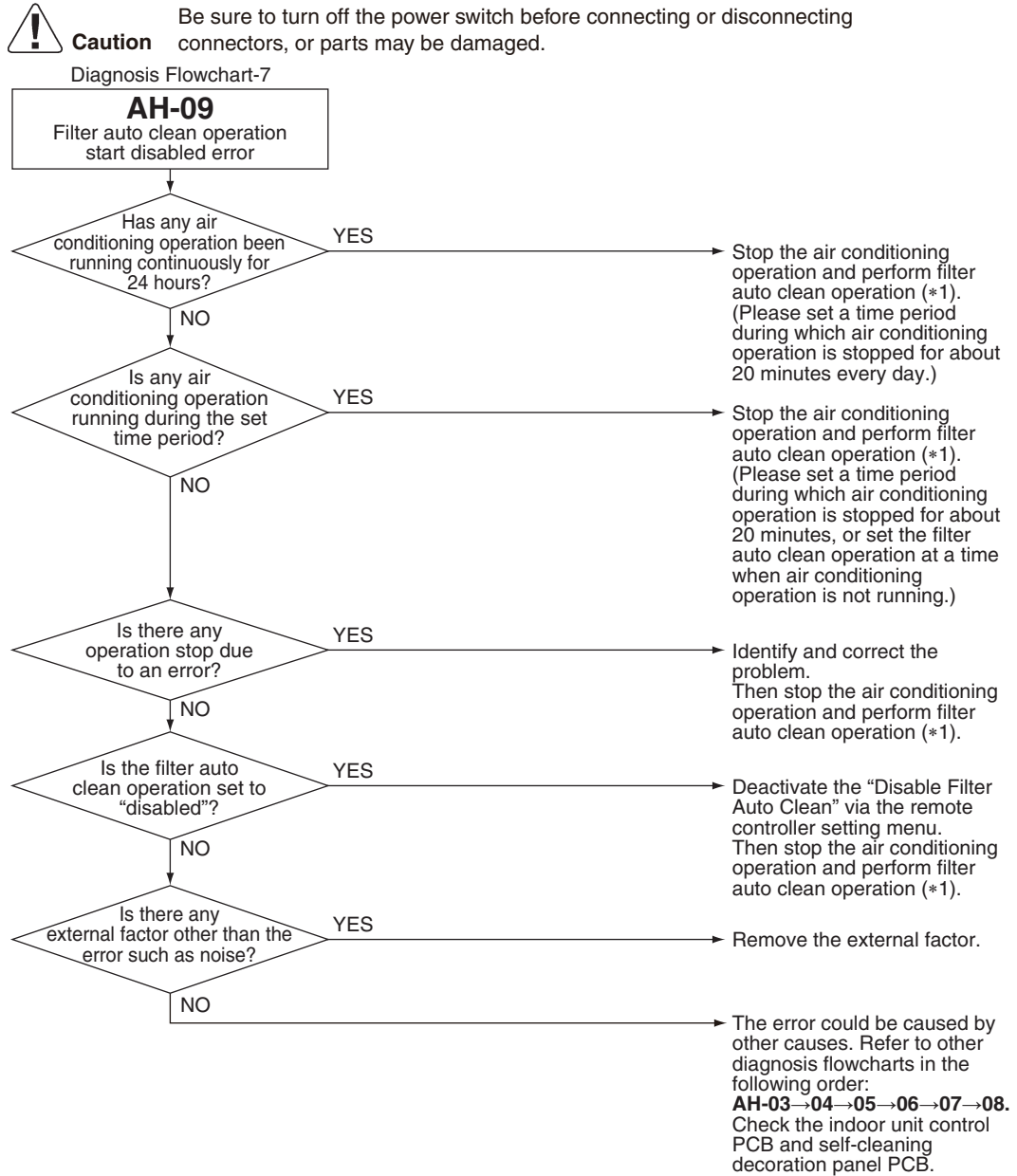

 **Note(s)**

\*1. If the filter auto clean operation mode is set to a designated time period, perform a filter auto clean operation as described below to clear the **AH** error code. (If scheduled operation time is not set, the filter auto clean operation will be performed automatically after air conditioning operation is stopped, so the following operation is unnecessary.)

1. On the remote controller, select "Filter Auto Clean" menu. The screen will change into a cleaning time period setting screen. Confirm the set time period. (Example: 0:00 to 3:00)
2. Select "Clock & Calendar" on the remote controller and set the current time to the time one minute before the beginning of the time set in step 1. (Example: If the set time is from 0:00 to 3:00, set the current time to 23:59, one minute before 0:00)
3. After about 1 minute, filter auto clean operation will start. (**AH** error cleared)
4. After confirming that the filter auto clean operation is finished, return the time changed in step 2 to the regular time.

## 5.18 Capacity Determination Device Abnormality

<b>Applicable Models</b>	All indoor unit models
<b>Error Code</b>	<b>AJ</b>
<b>Method of Error Detection</b>	Capacity is determined according to resistance of the capacity setting adaptor and the memory inside the IC memory on the indoor unit control PCB, and whether the value is normal or abnormal is determined.
<b>Error Decision Conditions</b>	When the capacity code is not saved to the PCB, and the capacity setting adaptor is not connected. When a capacity that does not exist for that unit is set.
<b>Supposed Causes</b>	<ul style="list-style-type: none"> <li>■ The capacity setting adaptor was not installed.</li> <li>■ Defective indoor unit control PCB</li> </ul>
<b>Troubleshooting</b>	

**Caution**

Be sure to turn off the power switch before connecting or disconnecting connectors, or parts may be damaged.

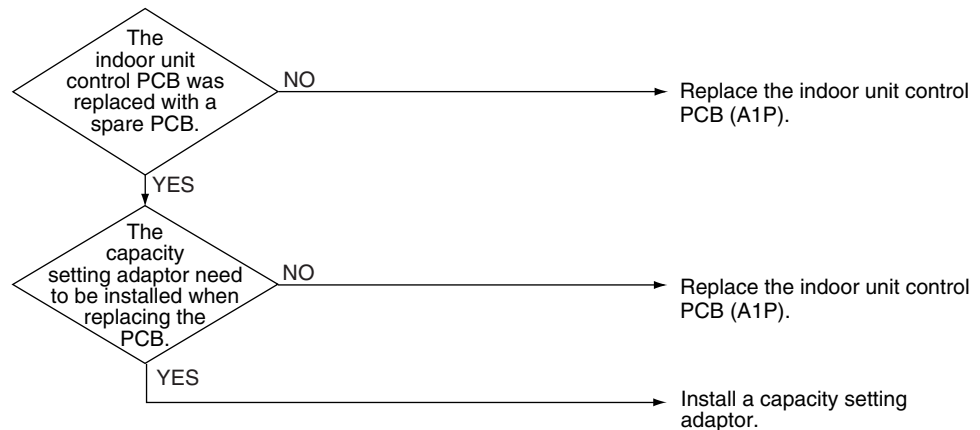

## 5.19 Transmission Abnormality between Indoor Unit Control PCB and Fan PCB

<b>Applicable Models</b>	FXSQ-TA, FXSQ-TB, FXMQ-PB, FXMQ-TB
<b>Error Code</b>	<b>C1</b>
<b>Method of Error Detection</b>	Transmission conditions between the indoor unit control PCB (A1P) and fan PCB (A2P) are checked via microcomputer.
<b>Error Decision Conditions</b>	When normal transmission is not carried out for a certain duration.
<b>Supposed Causes</b>	<ul style="list-style-type: none"> <li>■ Connection defective the connector between indoor unit control PCB (A1P) and fan PCB (A2P)</li> <li>■ Defective indoor unit control PCB (A1P)</li> <li>■ Defective fan PCB (A2P)</li> <li>■ External factor, such as instantaneous power failure</li> </ul>

## Troubleshooting

**Caution**

Be sure to turn off the power switch before connecting or disconnecting connectors, or parts may be damaged.

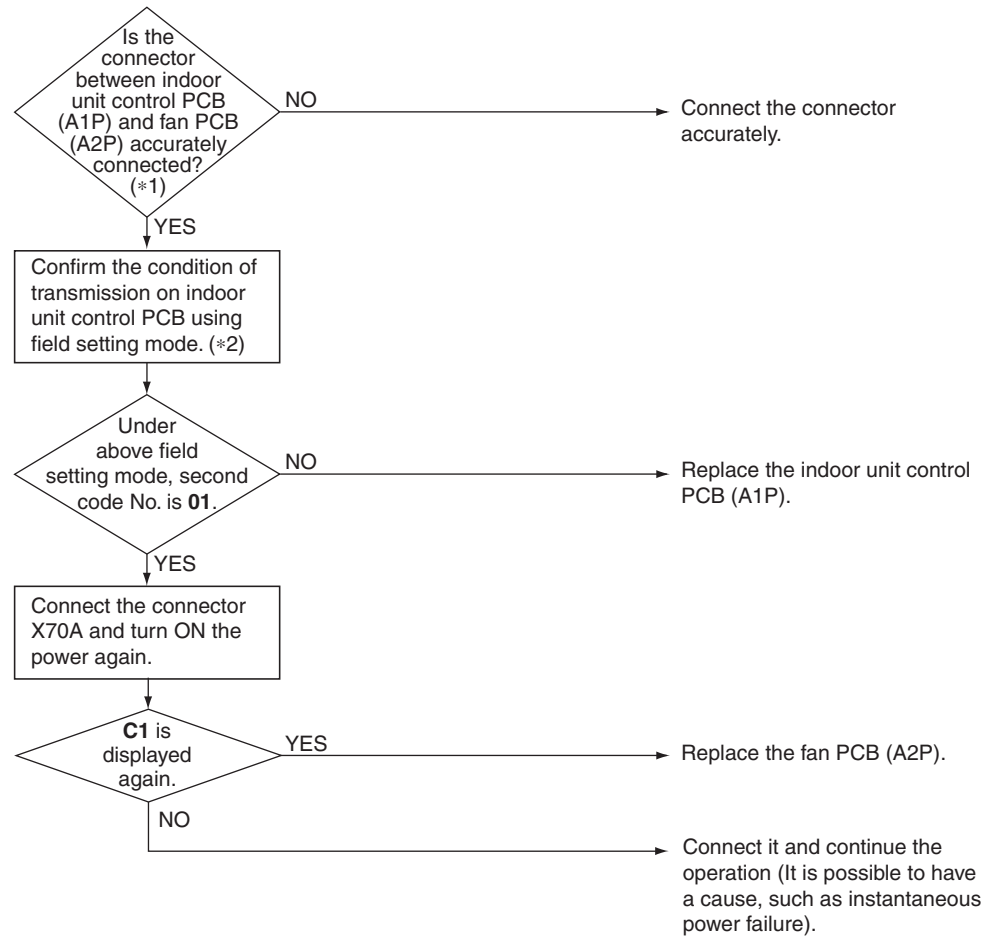
**Note(s)**

\*1. Pull out and insert the connector once and check if it is absolutely connected.

\*2. Method to check transmission part of indoor unit control PCB.

(1) Turn OFF the power and remove the connector X70A of indoor unit control PCB (A1P).

(2) Short circuit X70A.

(3) After turning ON the power, check below numbers under field setting from remote controller.

(Confirmation: Second code No. at the condition of first code No. 21 on mode No. 41)

Determination      01: Normal

Other than 01: Transmission error on indoor unit control PCB

\* After confirmation, turn OFF the power, take off the short circuit and connect X70A back to original condition.

## 5.20 Blower Motor Communication Error

<b>Applicable Models</b>	FXTQ-TA
<b>Error Code</b>	<b>C1-07</b>
<b>Outline</b>	Error is issued if transmission abnormalities occur between indoor unit and fan motor.
<b>Error Decision Conditions</b>	If the response message from the fan motor is an abnormal message, and determined as such by the indoor unit, the indoor unit will execute a retry. If everything fails for 5 seconds, it is deemed to be a transmission abnormality.
<b>Error Reset Conditions</b>	If the indoor unit receives even a single normal response message from the fan motor, the error will be cleared.
<b>Supposed Causes</b>	<ul style="list-style-type: none"> <li>■ Incorrect or loose wiring</li> <li>■ Power interruption (low voltage)</li> </ul>
<b>Corrective Actions</b>	<ul style="list-style-type: none"> <li>■ Check wiring or tighten wiring connections if needed.</li> <li>■ Verify the input voltage at the motor.</li> <li>■ Replace the indoor unit PCB or motor.</li> </ul>

## 5.21 Climate Talk Communication Error

<b>Applicable Models</b>	CXTQ-TA
<b>Error Code</b>	<b>C1-08</b>
<b>Method of Error Detection</b>	Monitors the communication with the gas furnace connected to the Climate Talk Communication terminal.
<b>Error Reset Conditions</b>	The error decision is made when the communication with the gas furnace is lost after once the initial setting for communication with the gas furnace completes.
<b>Supposed Causes</b>	<ul style="list-style-type: none"> <li>■ Disconnection of the communication wire between the CXTQ-TA and the gas furnace</li> <li>■ Power supply to the gas furnace is cut.</li> </ul>
<b>Troubleshooting</b>	

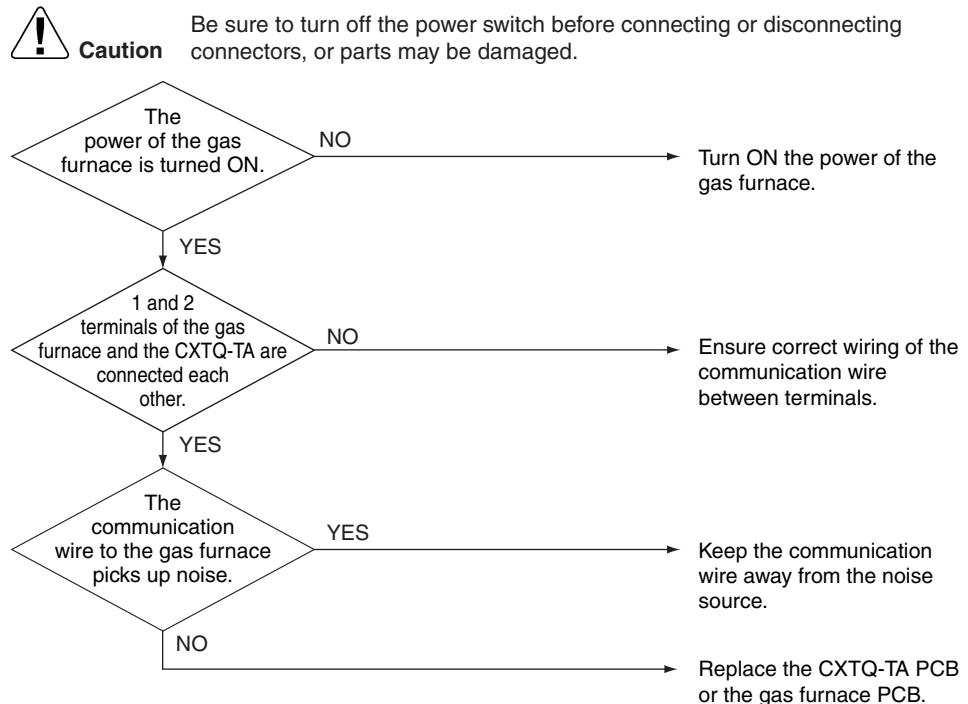

## 5.22 Thermistor Abnormality

**Applicable Models**  
**C4, C5:** All indoor units  
**C9:** except FXTQ-TA and CXTQ-TA models  
**CA:** FXMQ-PB models only

**Error Code**  
**C4, C5, C9, CA**

**Method of Error Detection**  
 The error is determined by the temperature detected by the thermistor.

**Error Decision Conditions**  
 The thermistor becomes disconnected or shorted while the unit is running.

- Supposed Causes**
- Defective thermistor
  - Defective indoor unit control PCB
  - Defective connector connection
  - Broken or disconnected wire

### Troubleshooting



**Caution** Be sure to turn off the power switch before connecting or disconnecting connectors, or parts may be damaged.

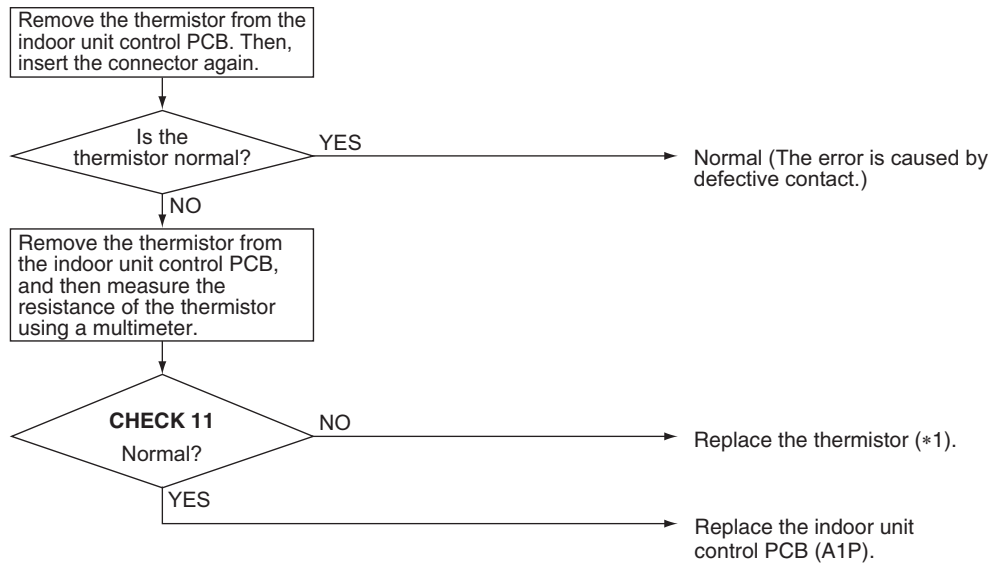

**Note(s)**

\*1. Error code and thermistor

Error Code	Thermistor	Except FXMQ-PB, FXTQ-TA, CXTQ-TA	FXMQ-PB	FXTQ-TA, CXTQ-TA
<b>C4</b>	Indoor heat exchanger liquid pipe thermistor	R2T	R2T	R2T
<b>C5</b>	Indoor heat exchanger gas pipe thermistor	R3T	R3T	R3T
<b>C9</b>	Suction air thermistor	R1T	R1T	*2
<b>CA</b>	Discharge air thermistor	—	R4T	—

\*2. Refer to page 245 for **C9** for FXTQ-TA and CXTQ-TA models.



**Reference**

**CHECK 11** Refer to page 320.



## 5.23 Combination Error between Indoor Unit Control PCB and Fan PCB

**Applicable Models** FXSQ-TA, FXSQ-TB, FXMQ-PB, FXMQ-TB

**Error Code** **C6**

**Method of Error Detection** Check the condition of transmission with fan PCB (A2P) using indoor unit control PCB (A1P).

**Error Decision Conditions** When the communication data of fan PCB (A2P) is determined as incorrect.

**Supposed Causes**

- Defective fan PCB (A2P)
- Defective connection of capacity setting adaptor
- Field setting error

### Troubleshooting

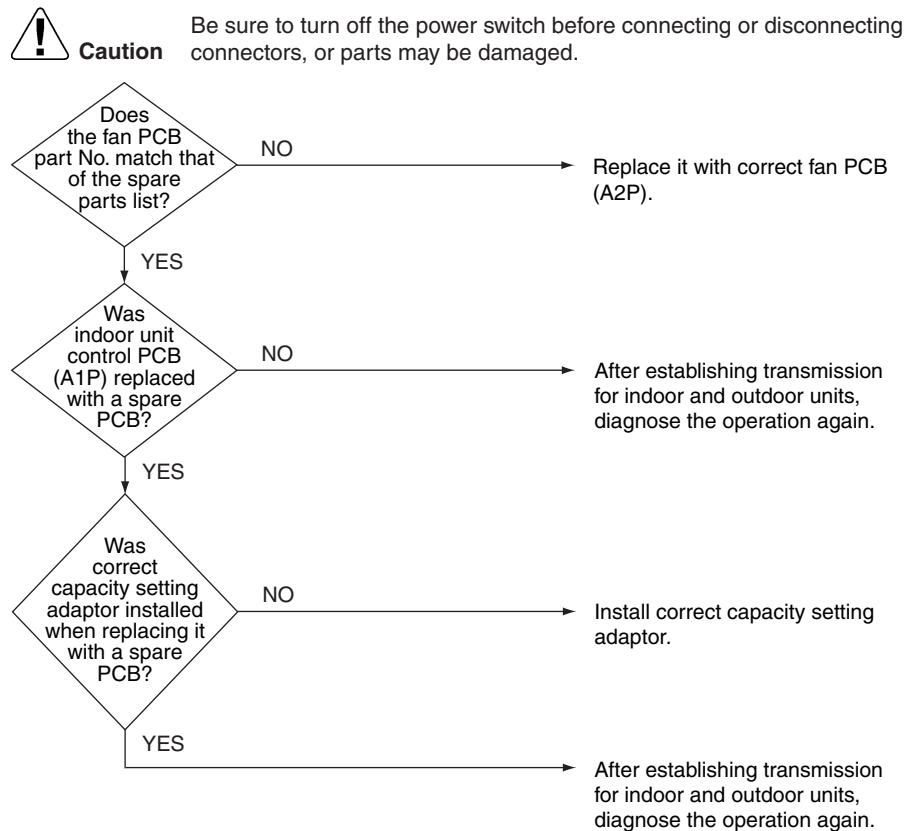

## 5.24 Blower Motor HP Mismatch

<b>Applicable Models</b>	FXTQ-TA
<b>Error Code</b>	<b>C6-01</b>
<b>Outline</b>	Error is issued if the manufacturer ID and output of the connected fan motor do not match those recognized by the indoor unit.
<b>Error Decision Conditions</b>	Gathers information on the manufacturer ID and output of the fan motor when initializing the fan motor. If those figures are not the values recognized by the indoor unit, it will be deemed abnormal operation. If deemed abnormal operation, it will keep retrying until the figures match.
<b>Error Reset Conditions</b>	If the manufacturer ID and output match, the error will be cleared.
<b>Supposed Causes</b>	<ul style="list-style-type: none"> <li>■ Incorrect size motor</li> <li>■ Indoor unit capacity setting error</li> </ul>
<b>Corrective Actions</b>	<ul style="list-style-type: none"> <li>■ Correct motor installation.</li> <li>■ Correct the indoor unit capacity setting.</li> </ul>

## 5.25 Indoor Blower Does Not Have Required Parameters to Function

---

**Applicable Models**FXTQ-TA

---

**Error Code****C6-02**

---

**Outline**

Indoor units perform required settings for control on the fan motor, but if the minimum required settings are not made then information indicating as such will be included among the periodic control status information.

Error is issued when the information shows abnormality.

---

**Error Decision Conditions**

If the parameter information shows abnormality, it will be deemed abnormal operation. At that point, parameter settings when initializing the fan motor will be implemented from the beginning.

---

**Error Reset Conditions**

If the parameter information is normal, the error will be cleared.

---

**Supposed Causes**

- Locked motor rotor condition
- 

**Corrective Actions**

- Check for locked rotor condition.
- Replace the indoor unit PCB or motor.

## 5.26 Remote Sensor Abnormality

<b>Applicable Models</b>	FXTQ-TA, CXTQ-TA
<b>Error Code</b>	<b>C9</b>
<b>Method of Error Detection</b>	The error is detected by remote sensor temperature.
<b>Error Decision Conditions</b>	When the remote sensor becomes disconnected or shorted while the unit is running.
<b>Supposed Causes</b>	<ul style="list-style-type: none"> <li>■ Defective indoor unit thermistor (R1T) for room temperature</li> <li>■ Defective indoor unit PCB</li> </ul>

### Troubleshooting

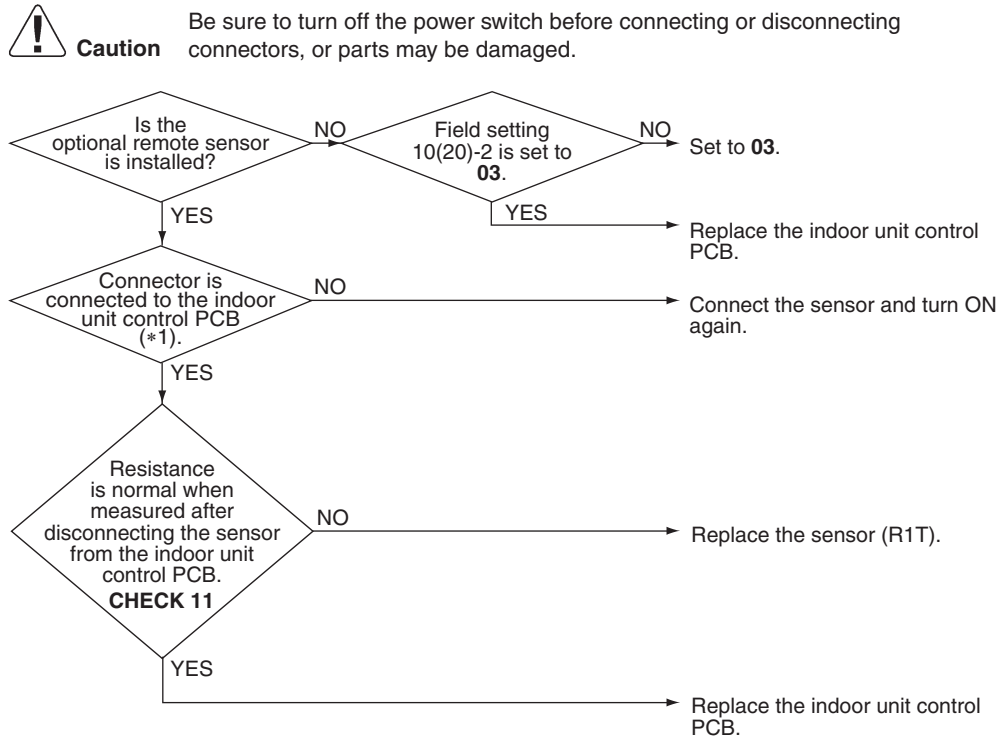

 **Note(s)** \*1. Connector and indoor unit control PCB

Connector for remote sensor	PCB
X4A	A1P

 **Reference** **CHECK 11** Refer to page 320.

## 5.27 Humidity Sensor System Abnormality

**Applicable Models** FXFQ-T, FXFQ-P

**Error Code** **CC**

**Method of Error Detection** Even if an error occurs, operation still continues.  
Error is detected according to the moisture (output voltage) detected by the moisture sensor.

**Error Decision Conditions** When the moisture sensor is disconnected or short circuited

**Supposed Causes**

- Defective sensor
- Disconnection

### Troubleshooting



**Caution**

Be sure to turn off the power switch before connecting or disconnecting connectors, or parts may be damaged.

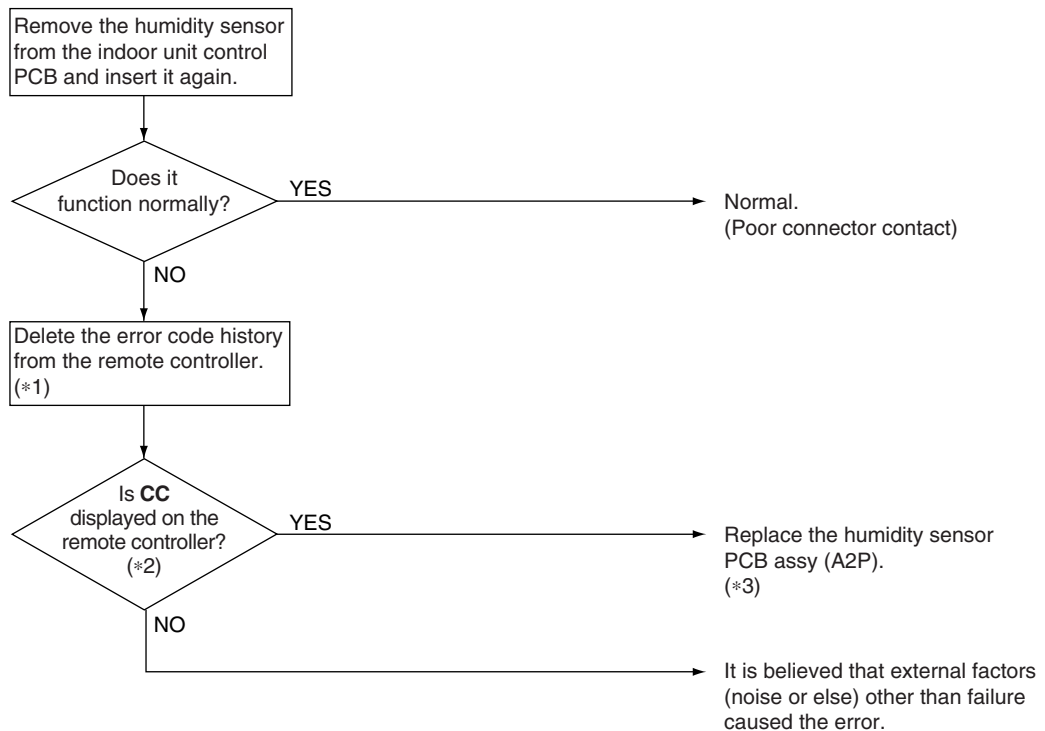

**Note(s)**

- \*1. To delete the history, the **ON/OFF** button of the remote controller must be pressed and held for 5 seconds in the check mode.
- \*2. To display the code, the **INSPECTION/TEST** button of the remote controller must be pressed and held in the normal mode.
- \*3. If **CC** is displayed even after replacing the humidity sensor PCB (A2P) and taking the steps \*1 and \*2, replace the indoor unit control PCB (A1P).

## 5.28 Infrared Presence/Floor Sensor Error

<b>Applicable Models</b>	FXFQ-T, FXZQ-TA, FXZQ-TB, FXUQ-P, FXUQ-PA
<b>Error Code</b>	<b>CE</b>
<b>Method of Error Detection</b>	The contents of a failure vary with the detailed error code. Check the code and proceed with the flowchart.
<b>Error Decision Conditions</b>	Error is detected based on sensor output signals
<b>Supposed Causes</b>	<ul style="list-style-type: none"> <li>■ Defective or disconnected infrared presence sensor connector: <b>CE-01</b></li> <li>■ Defective infrared floor sensor (Temperature compensation circuit disconnection): <b>CE-02</b></li> <li>■ Defective infrared floor sensor (Temperature compensation short circuit): <b>CE-03</b></li> <li>■ Defective infrared floor sensor element: <b>CE-04</b></li> </ul>

### Troubleshooting



**Caution**

Be sure to turn off the power switch before connecting or disconnecting connectors, or parts may be damaged.

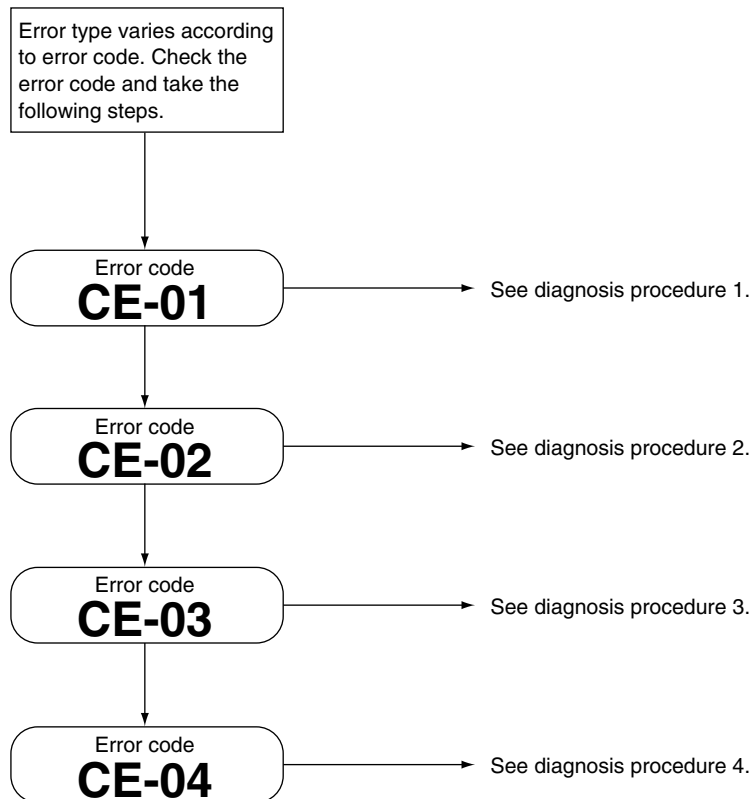

## Diagnosis procedure 1

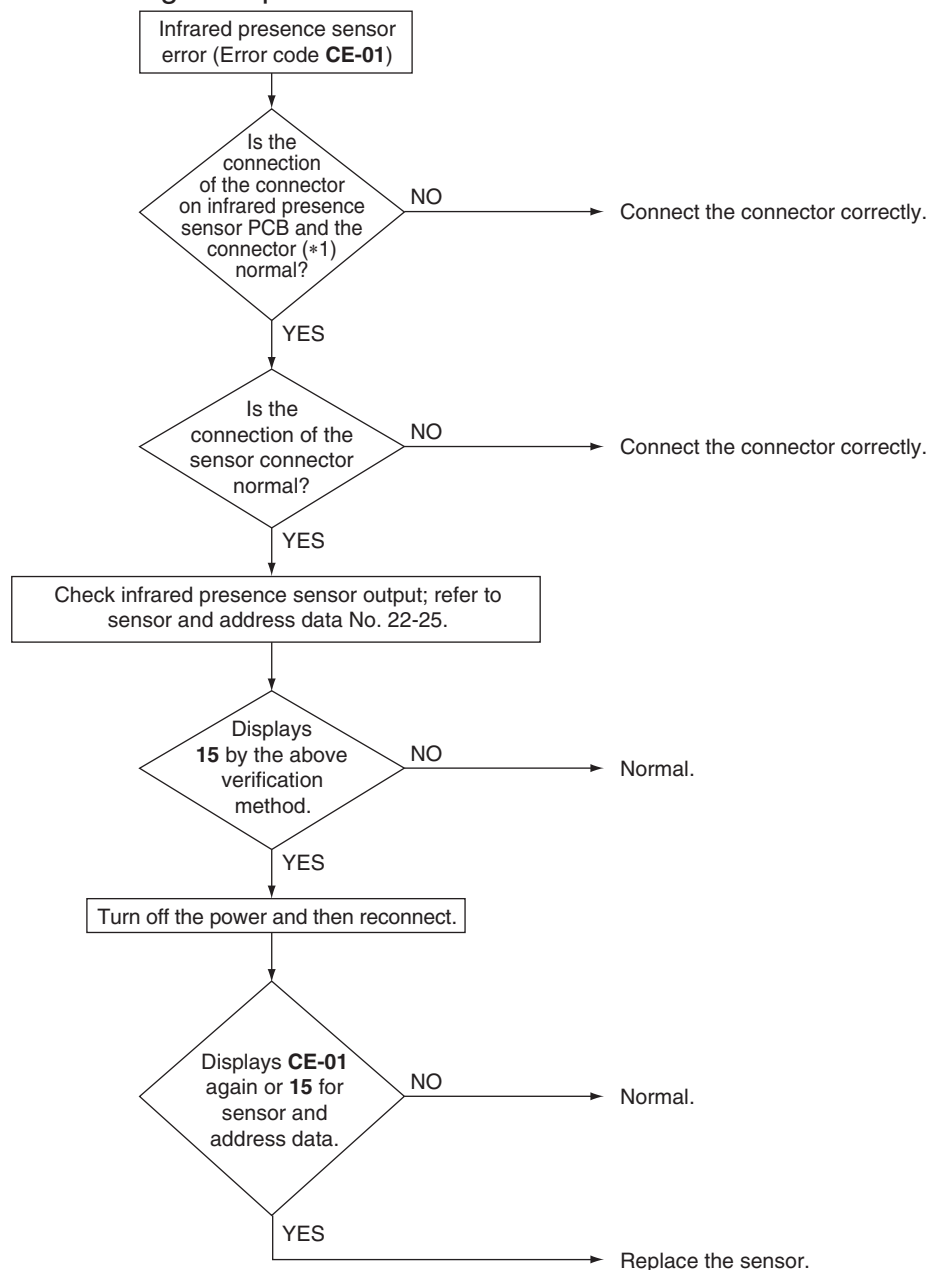

## Note(s)

\*1. Infrared presence sensor PCB and connector

Model	Infrared presence sensor PCB	Connector
FXFQ-T	A4P	X2A (A2P)
FXZQ-TA	A5P	X110A (A6P)
FXZQ-TB	A5P	X81A (A1P)
FXUQ-P	A4P	X81A (A1P)
FXUQ-PA	A4P	X81A (A1P)

### Diagnosis procedure 2

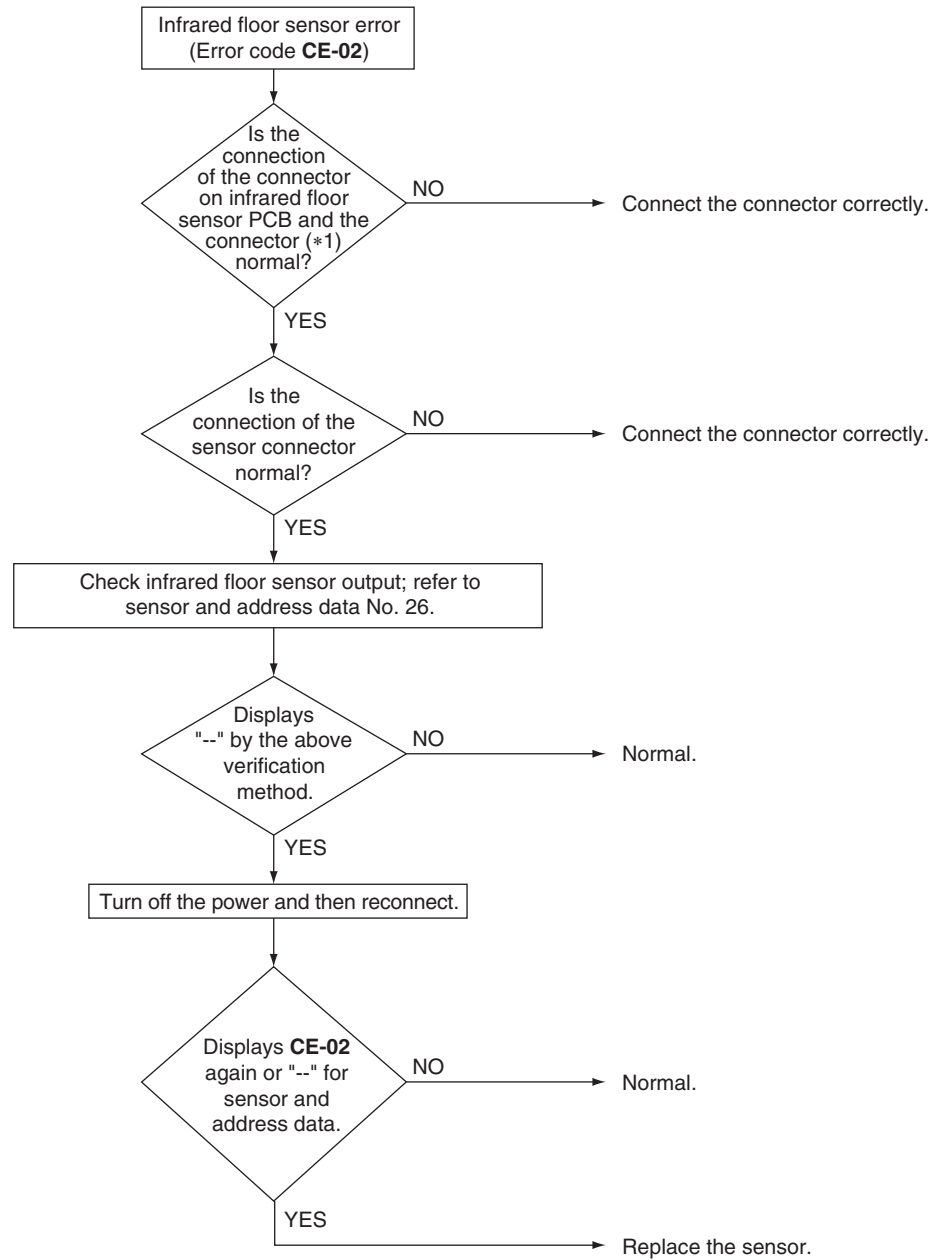

**Note(s)**

\*1. Infrared floor sensor PCB and connector

Model	Infrared floor sensor PCB	Connector
FXFQ-T	A3P	X2A (A2P)
FXZQ-TA	A4P	X110A (A6P)
FXZQ-TB	A4P	X81A (A1P)
FXUQ-P	A3P	X81A (A1P)
FXUQ-PA	A3P	X81A (A1P)



## Diagnosis procedure 3

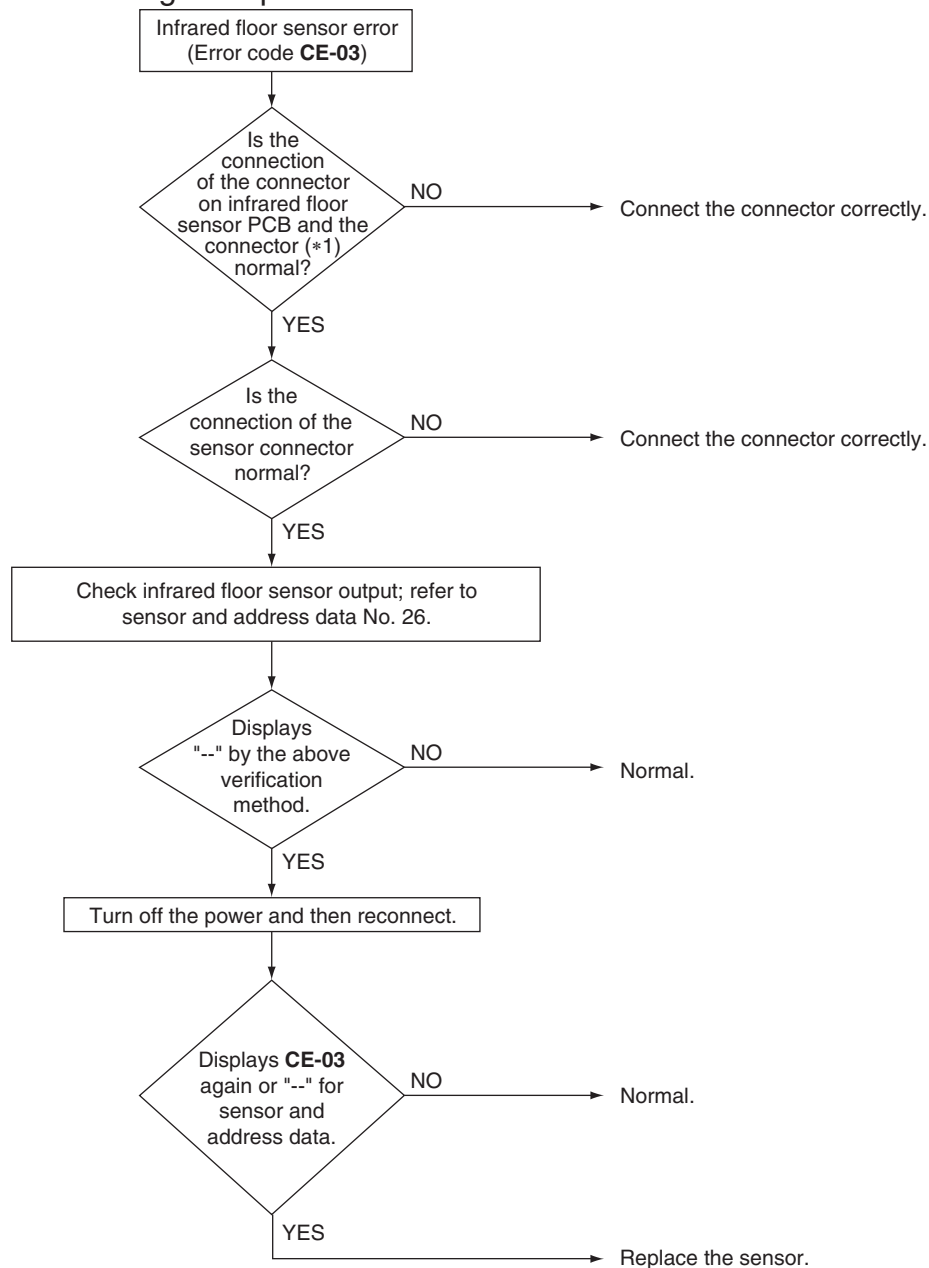

## Note(s)

\*1. Infrared floor sensor PCB and connector

Model	Infrared floor sensor PCB	Connector
FXFQ-T	A3P	X2A (A2P)
FXZQ-TA	A4P	X110A (A6P)
FXZQ-TB	A4P	X81A (A1P)
FXUQ-P	A3P	X81A (A1P)
FXUQ-PA	A3P	X81A (A1P)

Diagnosis procedure 4

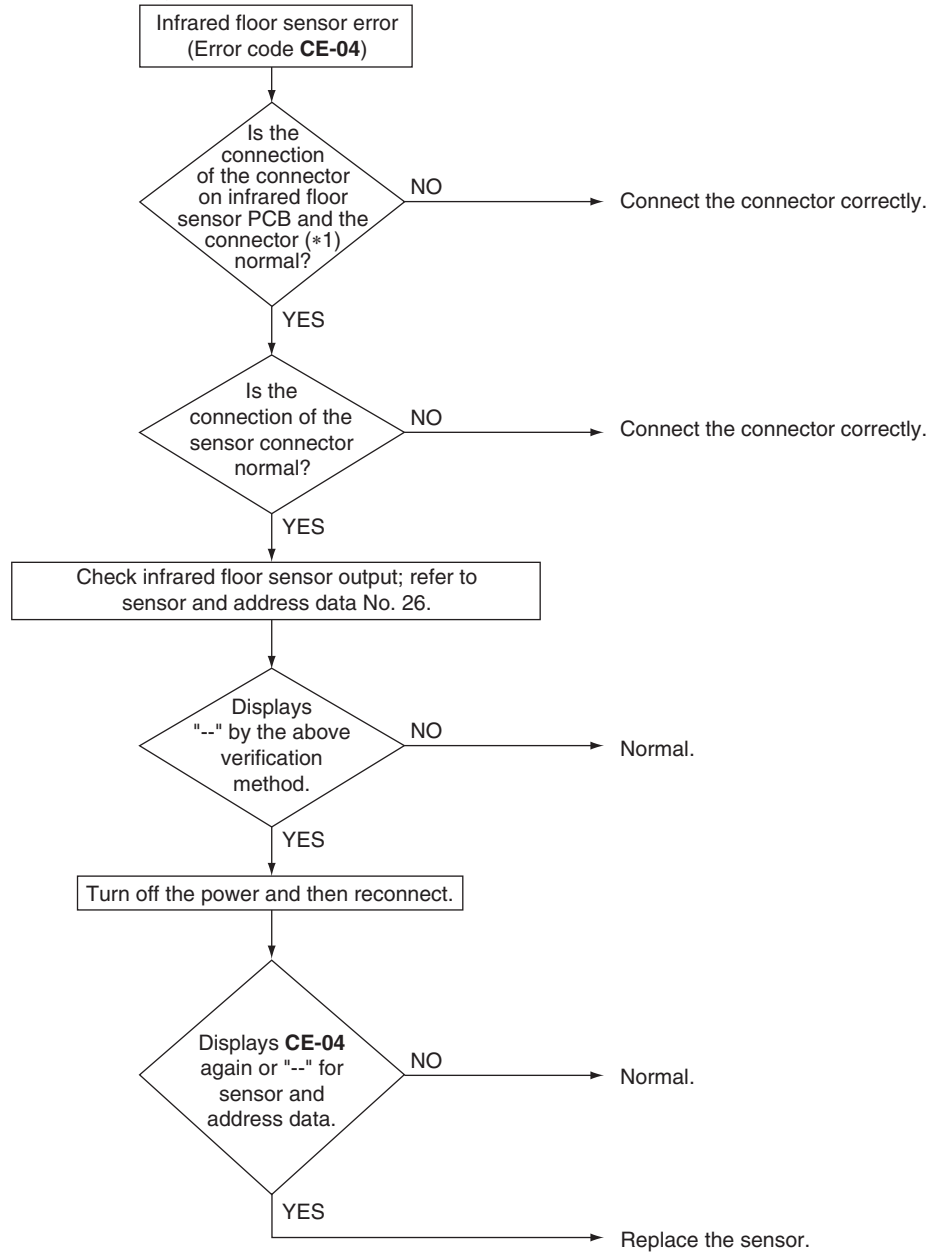

Note(s)

\*1. Infrared floor sensor PCB and connector

Model	Infrared floor sensor PCB	Connector
FXFQ-T	A3P	X2A (A2P)
FXZQ-TA	A4P	X110A (A6P)
FXZQ-TB	A4P	X81A (A1P)
FXUQ-P	A3P	X81A (A1P)
FXUQ-PA	A3P	X81A (A1P)

## 5.29 Remote Controller Thermistor Abnormality

<b>Applicable Models</b>	All indoor unit models
<b>Error Code</b>	<b>CJ</b>
<b>Method of Error Detection</b>	Error detection is carried out by the temperature detected by the remote controller thermistor.
<b>Error Decision Conditions</b>	The remote controller thermistor becomes disconnected or shorted while the unit is running. * Error code is displayed but the system operates continuously.
<b>Supposed Causes</b>	<ul style="list-style-type: none"> <li>■ Defective remote controller thermistor</li> <li>■ Defective remote controller PCB</li> </ul>
<b>Troubleshooting</b>	

**Caution**

Be sure to turn off the power switch before connecting or disconnecting connectors, or parts may be damaged.

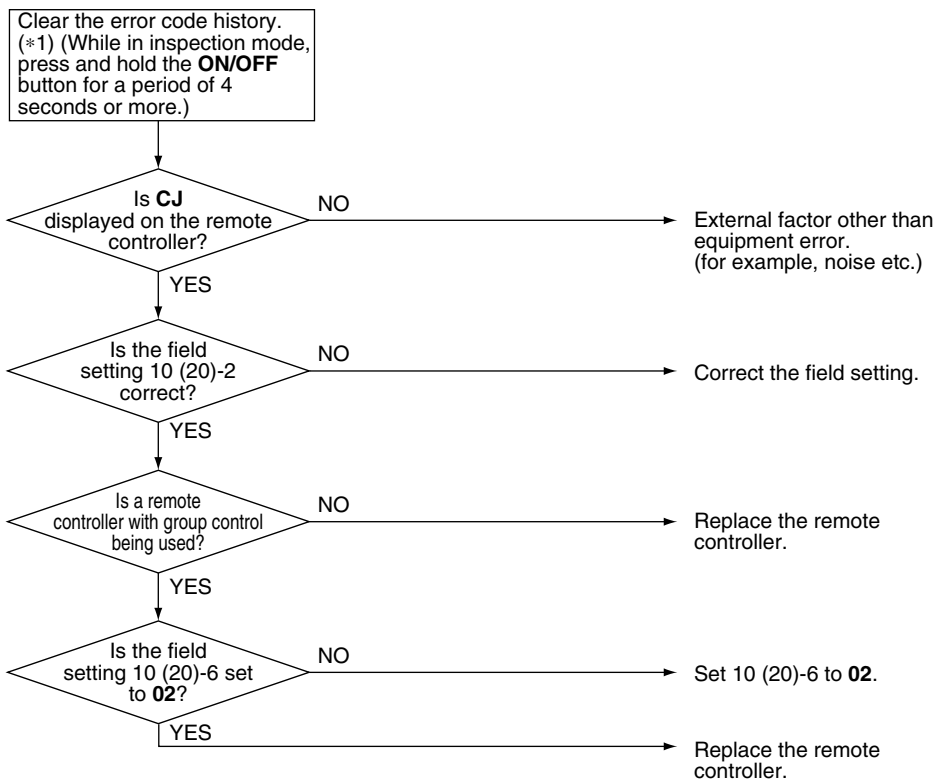
**Note(s)**

\*1: How to delete the history of error codes.

Press the **ON/OFF** button for 4 seconds and more while the error code is displayed in the inspection mode.

## 5.30 Outdoor Unit Main PCB Abnormality

**Applicable Models** All outdoor unit models

**Error Code** **E1**

**Method of Error Detection** Abnormality is detected under the communication conditions in the hardware section between the indoor unit and outdoor unit.

**Error Decision Conditions** When the communication conditions in the hardware section between the indoor unit and the outdoor unit are not normal.

- Supposed Causes**
- Defective outdoor unit main PCB (A1P)
  - Defective connection communication line between indoor and outdoor units

**Troubleshooting**

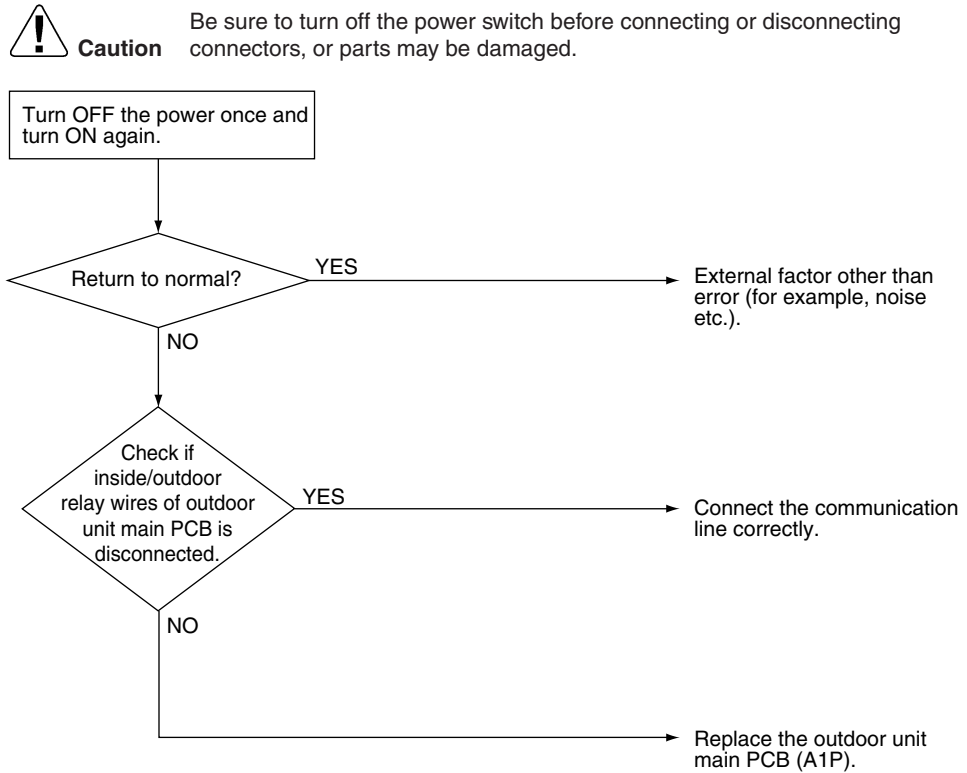

## 5.31 Activation of High Pressure Switch

<b>Applicable Models</b>	All outdoor unit models
<b>Error Code</b>	<b>E3</b>
<b>Method of Error Detection</b>	Detect continuity across the high pressure switch in the protection device circuit.
<b>Error Decision Conditions</b>	When part of the protection device circuit opens. (Reference) Operating pressure of the high pressure switch: <ul style="list-style-type: none"> <li>■ Operating pressure: 4.0 MPa (580 psi)</li> <li>■ Resetting pressure: 3.0 MPa (435 psi)</li> </ul>
<b>Supposed Causes</b>	<ul style="list-style-type: none"> <li>■ Activation of high pressure switch</li> <li>■ Defective high pressure switch</li> <li>■ Defective outdoor unit main PCB (A1P)</li> <li>■ Momentary power failure</li> <li>■ Defective high pressure sensor</li> </ul>

### Troubleshooting

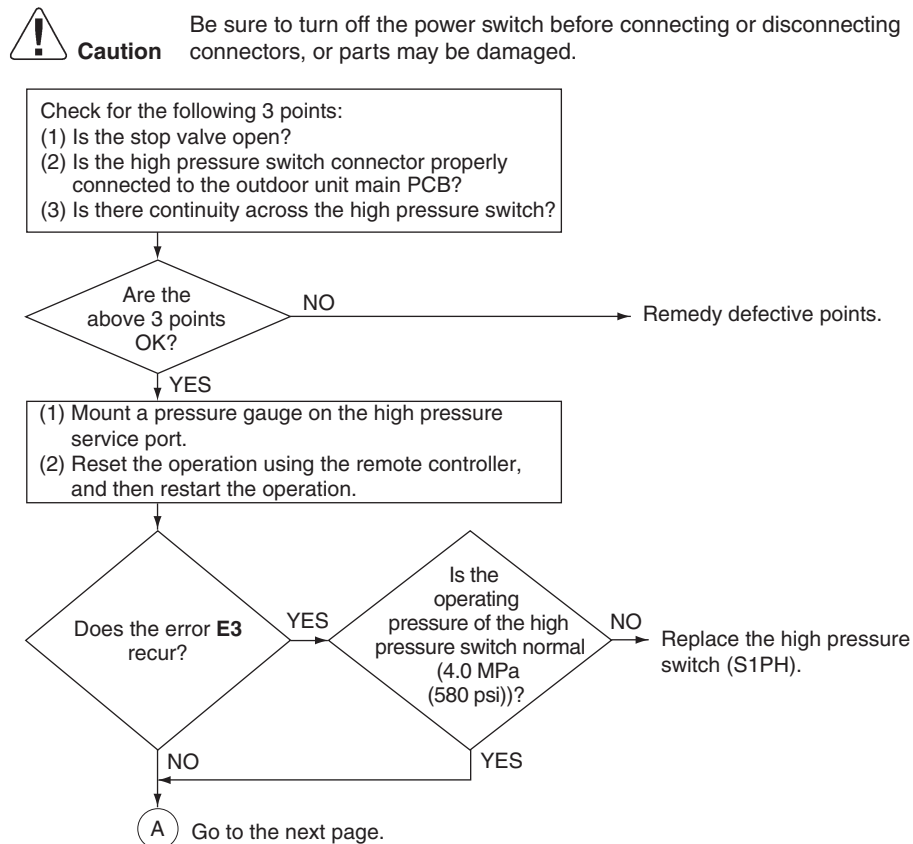

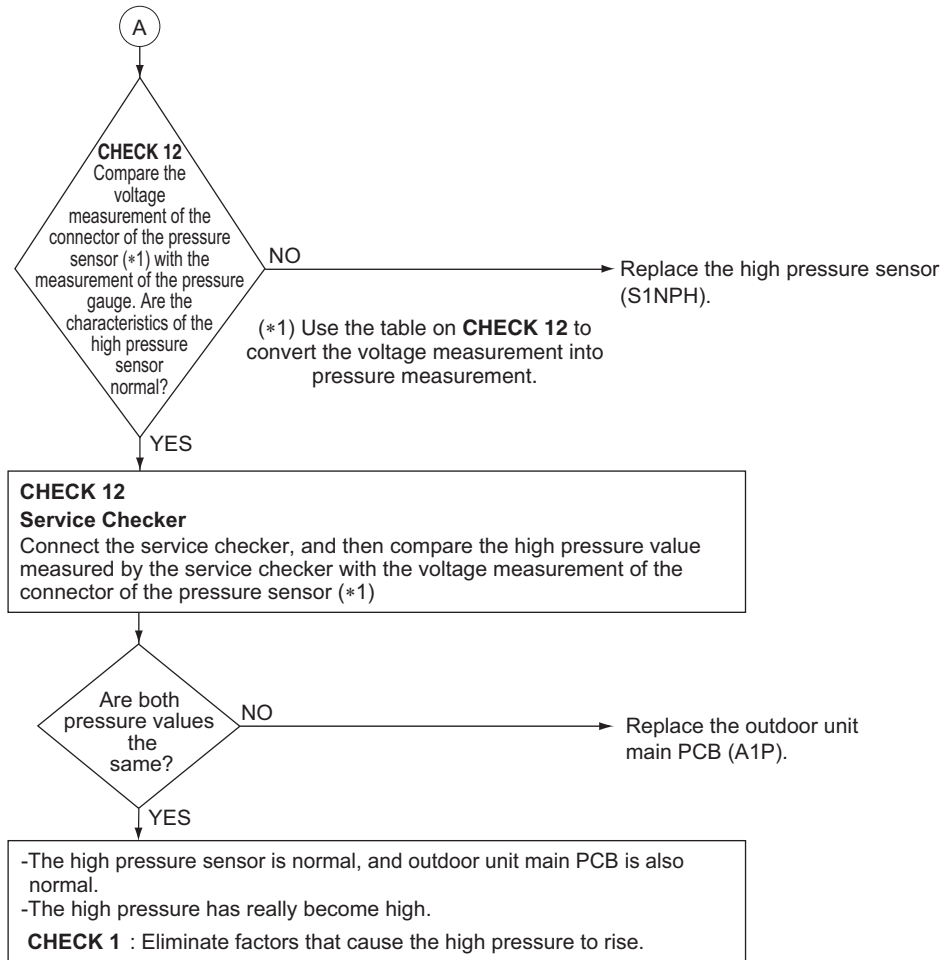

Reference **CHECK 1** Refer to page 309.



Reference **CHECK 12** Refer to page 323.

## 5.32 Activation of Low Pressure Sensor

<b>Applicable Models</b>	All outdoor unit models
<b>Error Code</b>	<b>E4</b>
<b>Method of Error Detection</b>	Make judgment of pressure detected by the low pressure sensor with the outdoor unit main PCB.
<b>Error Decision Conditions</b>	When low pressure caused a drop while the compressor is in operation: <ul style="list-style-type: none"> <li>■ Operating pressure: 0.07 MPa (10.2 psi)</li> </ul>
<b>Supposed Causes</b>	<ul style="list-style-type: none"> <li>■ Abnormal drop in low pressure</li> <li>■ Defective low pressure sensor</li> <li>■ Defective outdoor unit main PCB</li> <li>■ The stop valve is not opened</li> </ul>

### Troubleshooting

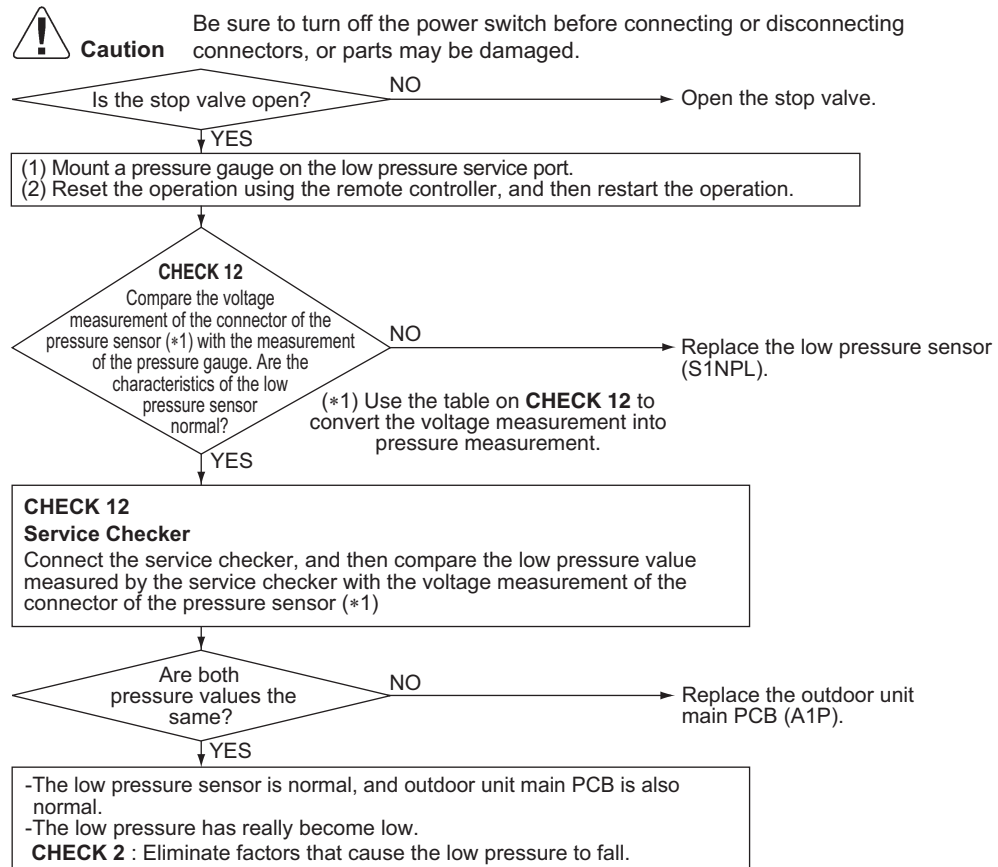

Reference

**CHECK 2** Refer to page 310.

Reference

**CHECK 12** Refer to page 323.

## 5.33 Compressor Motor Lock

**Applicable Models** All outdoor unit models

**Error Code** **E5**

**Method of Error Detection** PCB takes the position signal from UVW line connected between the inverter and compressor, and the error is detected when any abnormality is observed in the phase-current waveform.

**Error Decision Conditions** This error will be output when the inverter compressor motor does not start up even in forced startup mode.

- Supposed Causes**
- Inverter compressor lock
  - High differential pressure (0.5 MPa (72.5 psi) and above)
  - Incorrect UVW wiring
  - Defective PCB
  - Stop valve is not opened

### Troubleshooting



**Caution**

Be sure to turn off the power switch before connecting or disconnecting connectors, or parts may be damaged.

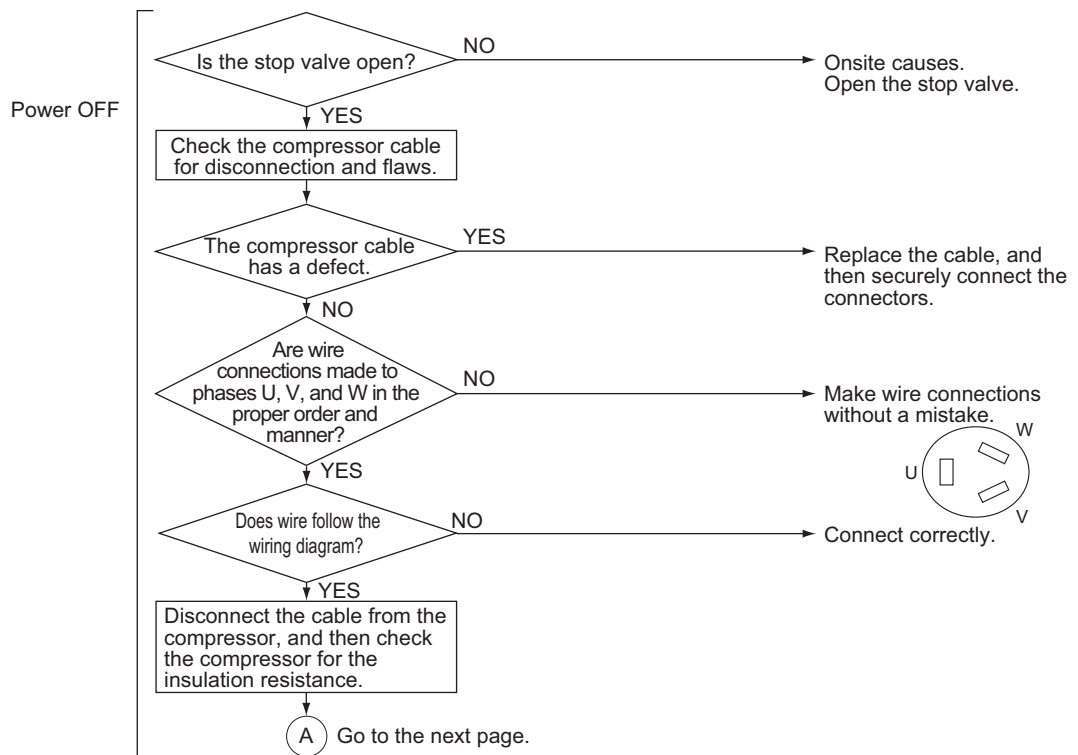



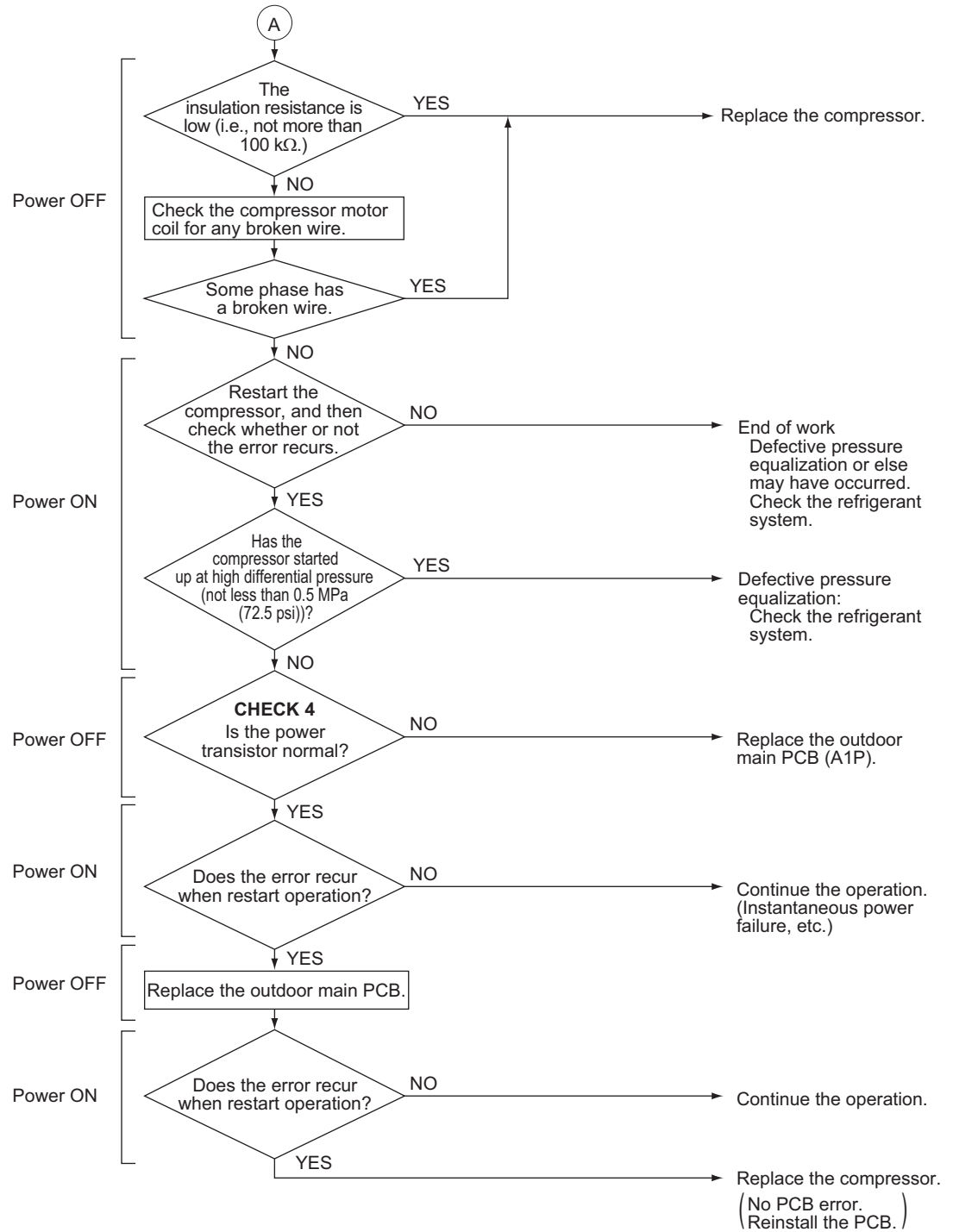

Reference

CHECK 4 Refer to page 314.

## 5.34 Outdoor Fan Motor Abnormality

---

**Applicable Models**

All outdoor unit models

---

**Error Code**

**E7**

---

**Method of Error Detection**

The fan motor circuit error is detected based on the rotation frequency detected by Hall IC during the fan motor operation.

---

**Error Decision Conditions**

In the condition of fan motor rotation, the number of rotation is below the fixed number for more than 6 seconds. (System down is caused by 4 times of detection.)

---

**Supposed Causes**

- Defective fan motor
- Defect or connection error of the connectors/ harness between the fan motor and PCB
- The fan cannot rotate due to obstruction of foreign matter.
- Clear condition: Continue normal operation for 5 minutes
- Missing phase L1 and missing phase N

Troubleshooting



**Caution** Be sure to turn off the power switch before connecting or disconnecting connectors, or parts may be damaged.

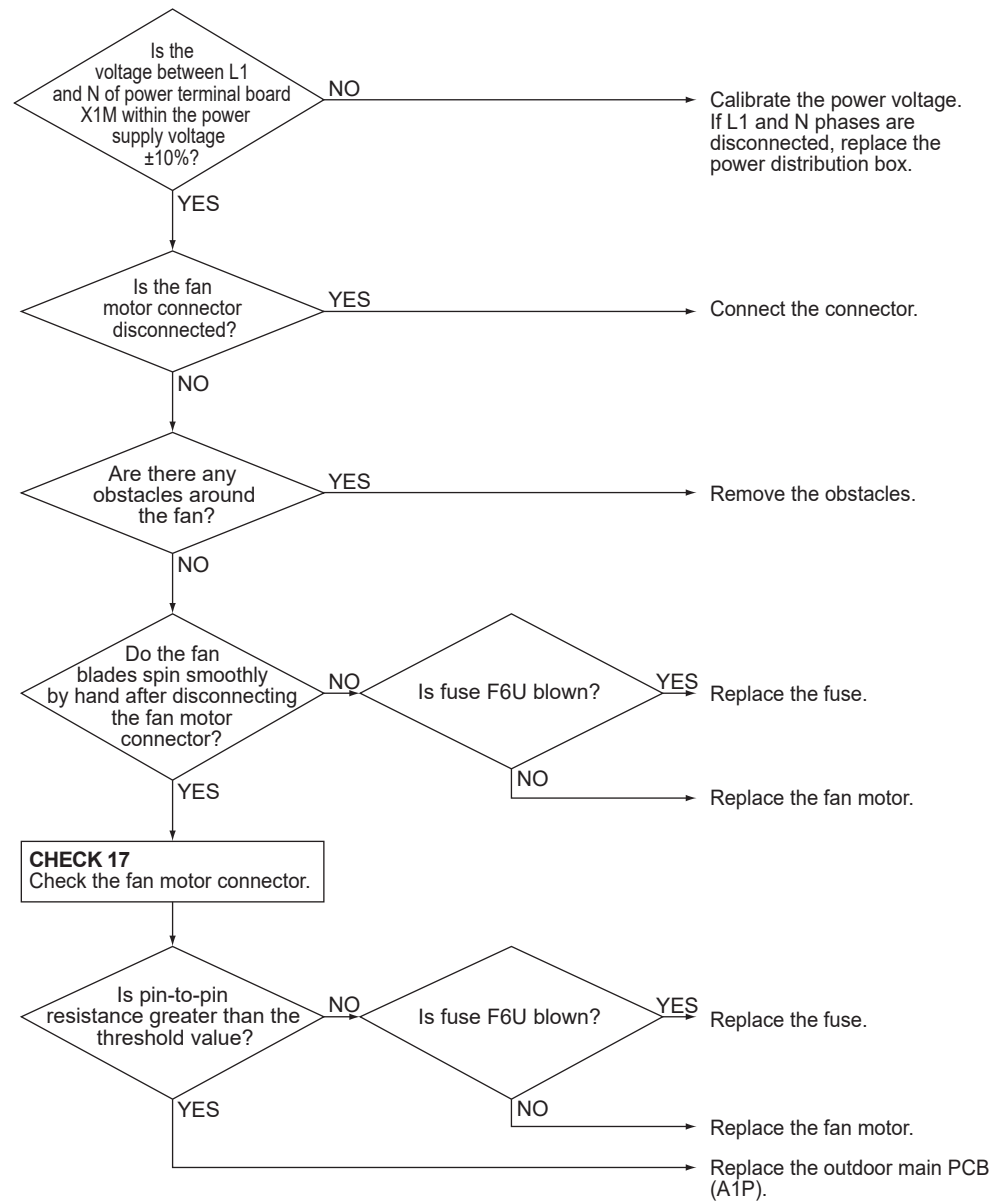

Reference

**CHECK 17** Refer to page 327.

## 5.35 Electronic Expansion Valve Coil Abnormality

**Applicable Models** All outdoor unit models

**Error Code** **E9**

**Method of Error Detection** Check continuity of electronic expansion valve coil.

**Error Decision Conditions** No current is detected in the common (COM [+]) when power supply is ON.

- Supposed Causes**
- Defective electronic expansion valve coil
  - Defective outdoor unit main PCB
  - Disconnection of connectors for electronic expansion valve

**Troubleshooting**



**Caution** Be sure to turn off the power switch before connecting or disconnecting connectors, or parts may be damaged.

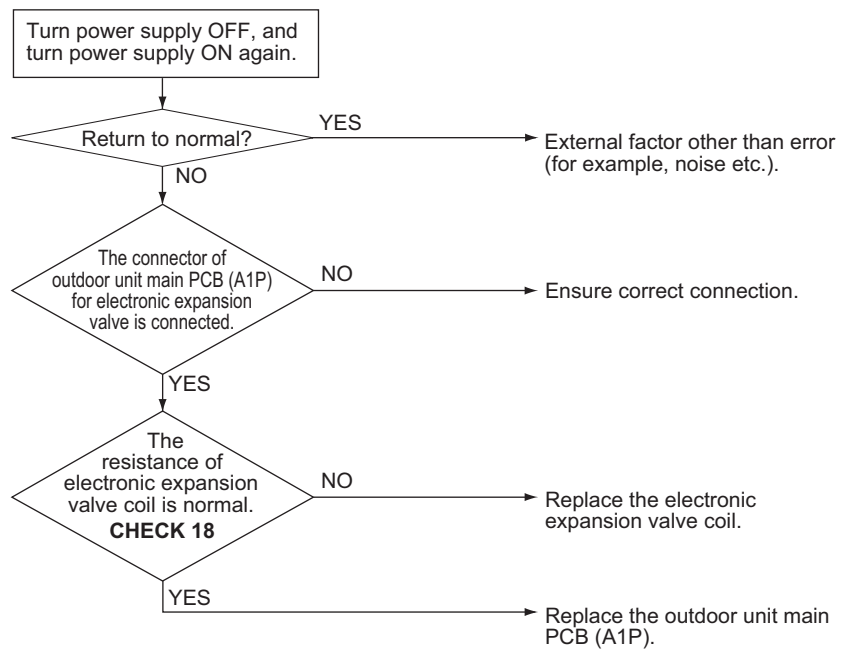

**Reference** **CHECK 18** Refer to page 329.

## 5.36 Discharge Pipe Temperature Abnormality

<b>Applicable Models</b>	All outdoor unit models
<b>Error Code</b>	<b>F3</b>
<b>Method of Error Detection</b>	Abnormality is detected according to the temperature detected by the discharge pipe thermistor.
<b>Error Decision Conditions</b>	The discharge pipe temperature rises to an abnormally high level. The discharge pipe temperature rises suddenly.
<b>Supposed Causes</b>	<ul style="list-style-type: none"> <li>■ Defective discharge pipe thermistor (R2T)</li> <li>■ Disconnection of discharge pipe thermistor (R2T)</li> <li>■ Defective outdoor unit PCB</li> </ul>

### Troubleshooting



**Caution** Be sure to turn off the power switch before connecting or disconnecting connectors, or parts may be damaged.

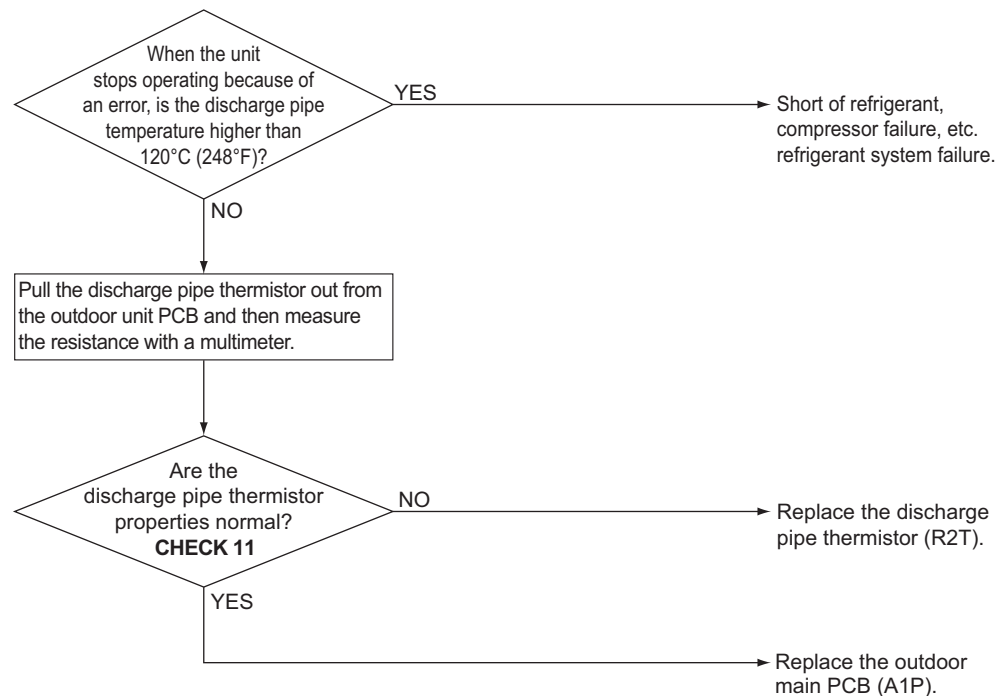

**Reference**

**CHECK 11** Refer to page 320.

## 5.37 Thermistor Abnormality

**Applicable Models** All outdoor unit models

**Error Code** **H9, J3, J5, J6, J7, J9**

**Method of Error Detection** Error is detected from the temperature detected by the thermistor (\*1).

**Error Decision Conditions** The thermistor has short circuit or open circuit.

- Supposed Causes**
- Defective thermistor
  - Defective outdoor unit main PCB
  - Disconnection of thermistor.

### Troubleshooting



**Caution** Be sure to turn off the power switch before connecting or disconnecting connectors, or parts may be damaged.

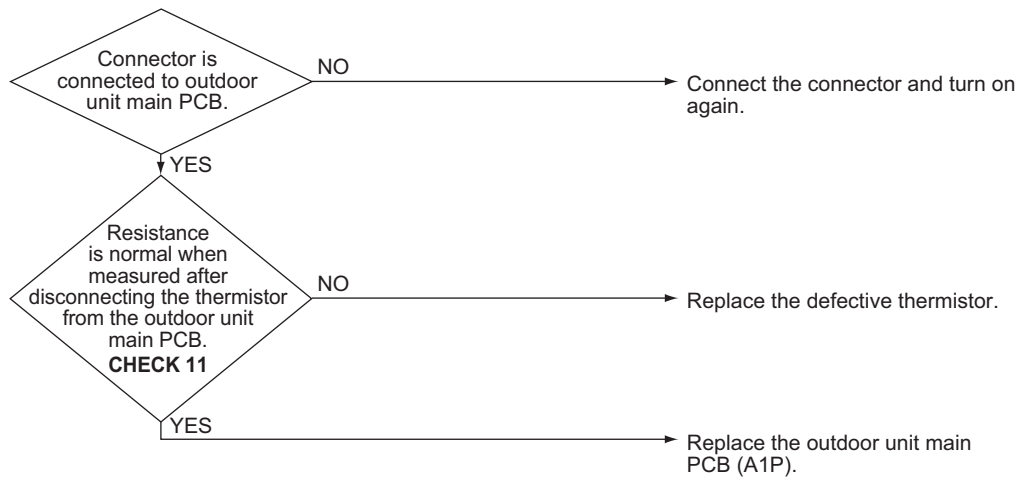

**Reference** **CHECK 11** Refer to page 320.



**Note(s)** \*1. Thermistor

Error code	Thermistor	24/36/48 class		60 class	
		Symbol	Connector	Symbol	Connector
H9	Outdoor air thermistor	R1T	X11A	R1T	X11A
J3	Discharge pipe thermistor	R2T	X12A	R2T	X12A
J5	Suction pipe thermistor	R3T		R3T	
		R5T		R5T	
J6	Outdoor heat exchanger deicer thermistor	R4T		R4T	
J7	Outdoor heat exchanger liquid pipe thermistor	R7T	X13A	R7T	X13A
J9	Subcooling heat exchanger gas pipe thermistor	—	—	R6T	

## 5.38 High Pressure Sensor Abnormality

<b>Applicable Models</b>	All outdoor unit models
<b>Error Code</b>	<b>JA</b>
<b>Method of Error Detection</b>	Error is detected from the pressure detected by the high pressure sensor.
<b>Error Decision Conditions</b>	The high pressure sensor is short circuit or open circuit. Pressure range: 0-4.3 MPa (0-624 psi)
<b>Supposed Causes</b>	<ul style="list-style-type: none"> <li>■ Defective high pressure sensor</li> <li>■ Connection of low pressure sensor with wrong connection</li> <li>■ Defective outdoor unit main PCB</li> <li>■ Disconnection of high pressure sensor</li> </ul>

### Troubleshooting

**Caution**

Be sure to turn off the power switch before connecting or disconnecting connectors, or parts may be damaged.

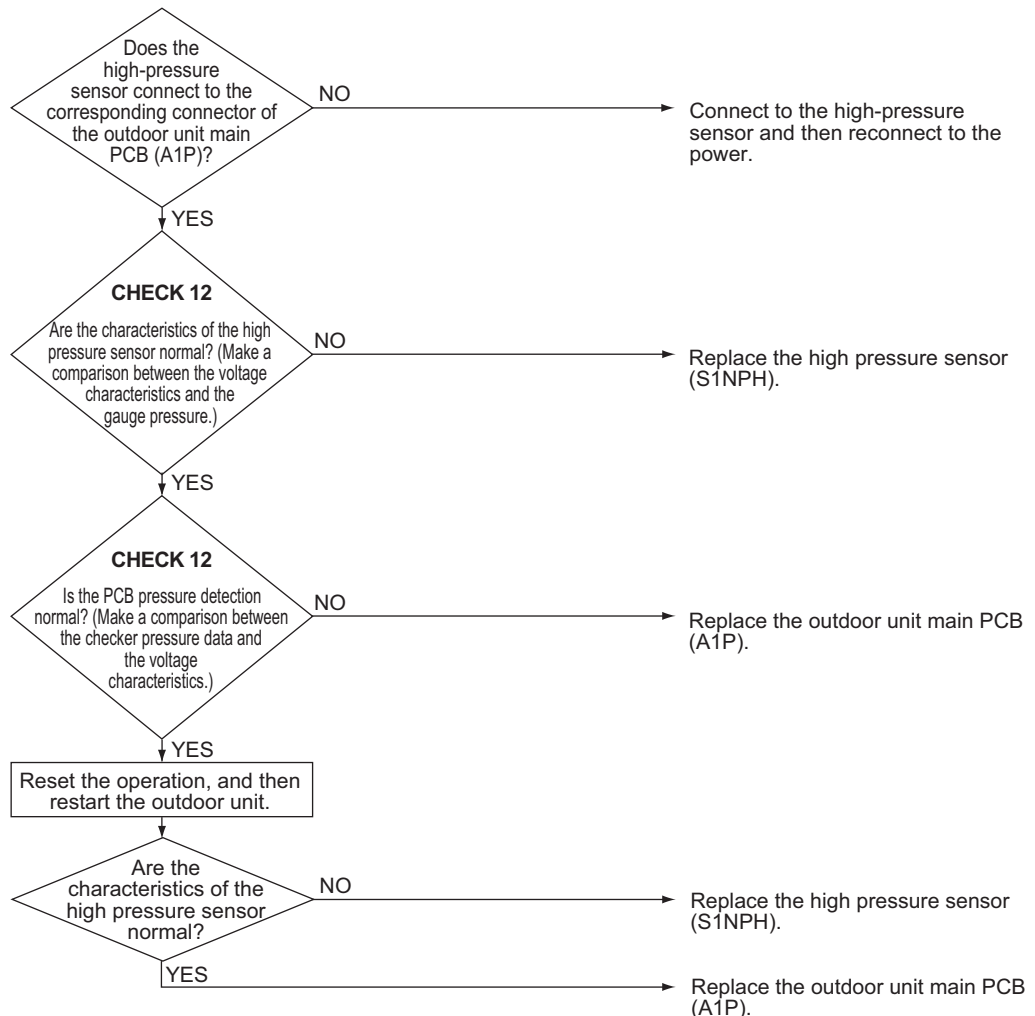
**Reference**
**CHECK 12** Refer to page 323.

## 5.39 Low Pressure Sensor Abnormality

**Applicable Models** All outdoor unit models

**Error Code** **JC**

**Method of Error Detection** Error is detected from pressure detected by low pressure sensor.

**Error Decision Conditions** The low pressure sensor is short circuit or open circuit.  
Pressure range: 0-1.7 MPa (0-247 psi)

- Supposed Causes**
- Defective low pressure sensor
  - Connection of high pressure sensor with wrong connection
  - Defective outdoor unit main PCB
  - Disconnection of low pressure sensor

### Troubleshooting



**Caution** Be sure to turn off the power switch before connecting or disconnecting connectors, or parts may be damaged.

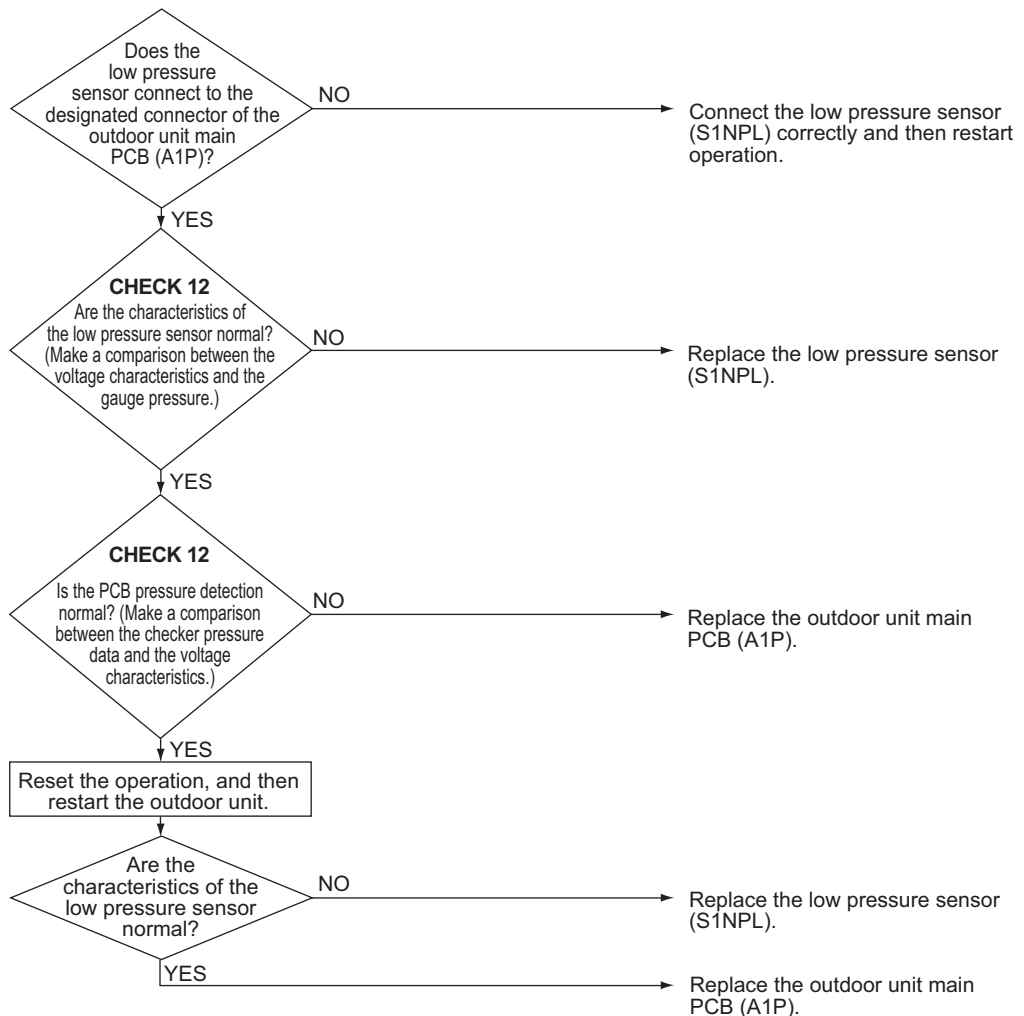

Reference

**CHECK 12** Refer to page 323.



## 5.40 Inverter PCB Abnormality

<b>Applicable Models</b>	All outdoor unit models
<b>Error Code</b>	<b>L1</b>
<b>Method of Error Detection</b>	<ul style="list-style-type: none"> <li>■ Error is detected based on the current value during waveform output before starting compressor.</li> <li>■ Error is detected based on the value from current sensor during synchronous operation when starting the unit.</li> </ul>
<b>Error Decision Conditions</b>	<ul style="list-style-type: none"> <li>■ Overcurrent (OCP) flows during waveform output.</li> <li>■ Error of current sensor during synchronous operation.</li> <li>■ IPM failure.</li> </ul>
<b>Supposed Causes</b>	<ul style="list-style-type: none"> <li>■ IPM failure</li> <li>■ Current sensor failure</li> <li>■ Drive circuit failure</li> </ul>

### Troubleshooting

**Caution**

Be sure to turn off the power switch before connecting or disconnecting connectors, or parts may be damaged.

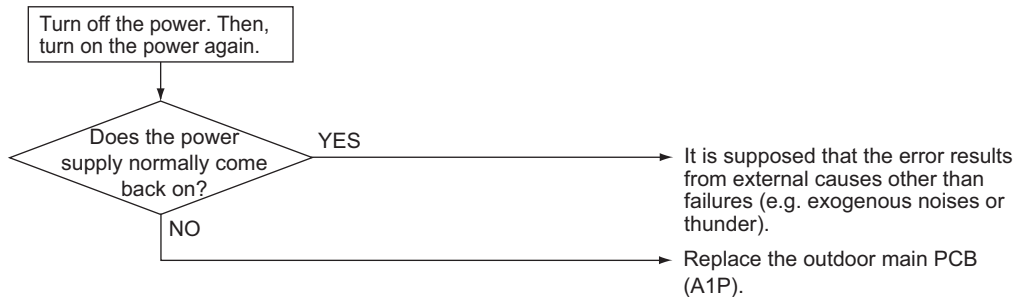

## 5.41 Radiation Fin Temperature Rise Abnormality

**Applicable Models** All outdoor unit models

**Error Code** **L4**

**Method of Error Detection** The radiation fin temperature is detected by the radiation fin thermistor.

**Error Decision Conditions** The radiation fin temperature exceeds a certain temperature.

- Supposed Causes**
- Activation of radiation fin thermistor
  - Defective outdoor main PCB
  - Defective radiation fin thermistor

### Troubleshooting



**Caution** Be sure to turn off the power switch before connecting or disconnecting connectors, or parts may be damaged.

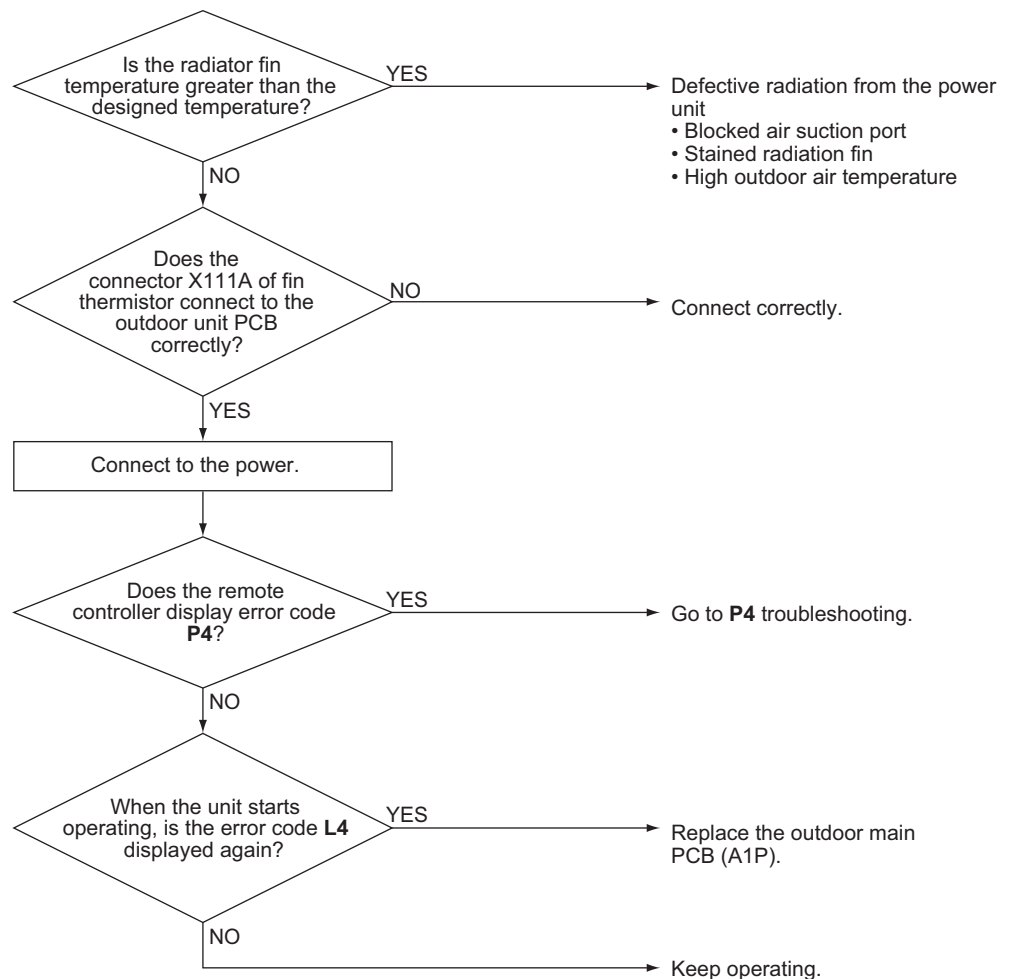

## 5.42 Compressor Instantaneous Overcurrent

**Applicable Models** All outdoor unit models

**Error Code** **L5**

**Method of Error Detection** Error is detected from current flowing in the power transistor.

**Error Decision Conditions** An excessive current flows in the power transistor.

**Supposed Causes**

- Defective compressor coil (disconnected, defective insulation)
- Defective compressor startup (mechanical lock)
- Defective PCB

### Troubleshooting



**Caution** Be sure to turn off the power switch before connecting or disconnecting connectors, or parts may be damaged.

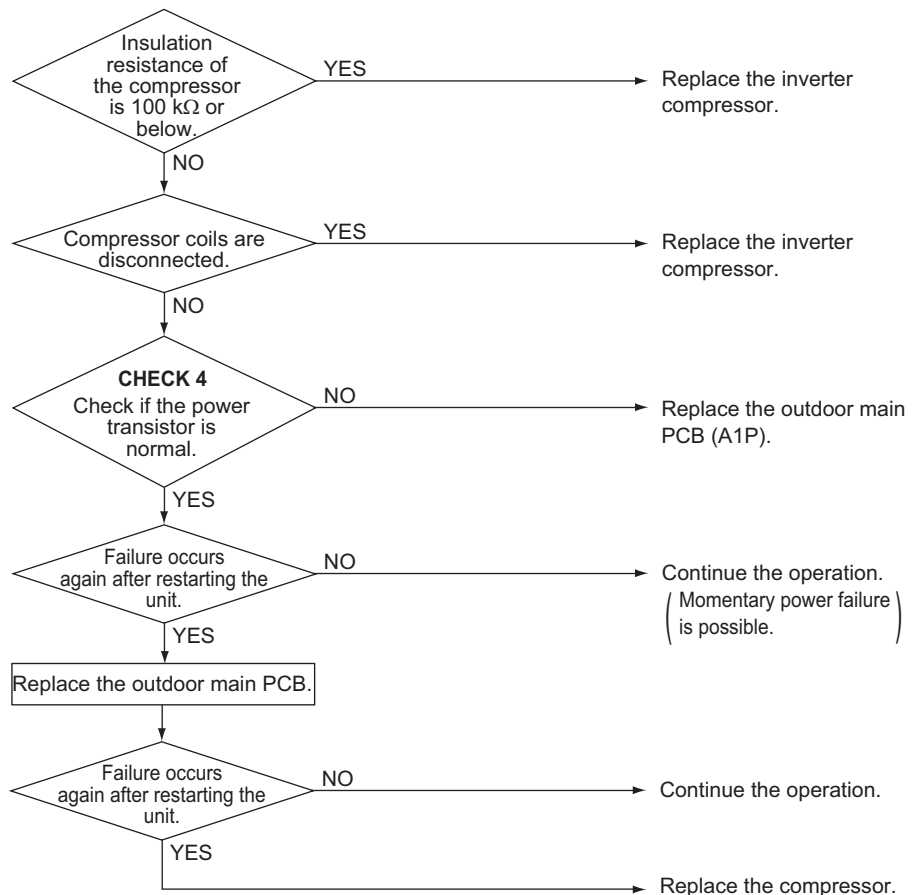

**Reference** **CHECK 4** Refer to page 314.

## 5.43 Compressor Overcurrent

<b>Applicable Models</b>	All outdoor unit models
<b>Error Code</b>	<b>L8</b>
<b>Method of Error Detection</b>	Error is detected by current flowing in the power transistor.
<b>Error Decision Conditions</b>	Overload in the compressor is detected.
<b>Supposed Causes</b>	<ul style="list-style-type: none"> <li>■ Compressor overload</li> <li>■ Broken wire inside compressor</li> <li>■ Defective PCB</li> <li>■ Disconnection of compressor</li> </ul>

### Troubleshooting



**Caution** Be sure to turn off the power switch before connecting or disconnecting connectors, or parts may be damaged.

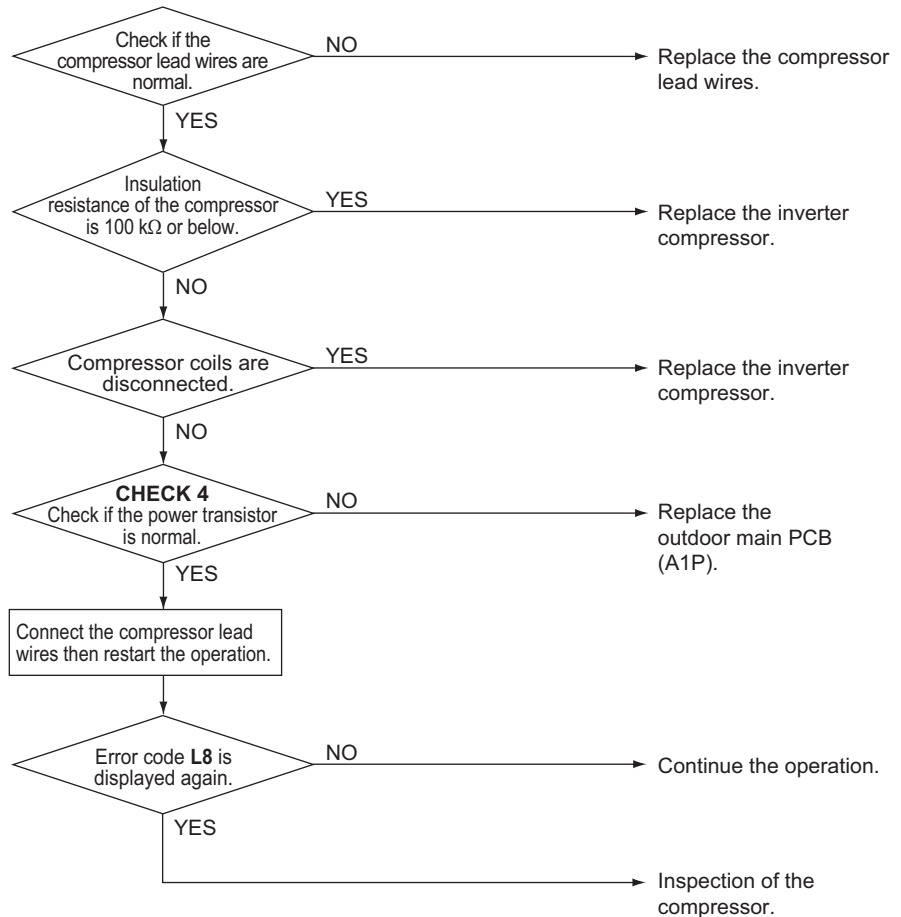

**Reference** **CHECK 4** Refer to page 314.

## 5.44 Compressor Startup Abnormality

**Applicable Models** All outdoor unit models

**Error Code** **L9**

**Method of Error Detection** Error is detected by the power transistor current

**Error Decision Conditions** Compressor overload during activation

**Supposed Causes**

- Defective compressor
- Large pressure difference before starting the compressor
- Defective PCB

### Troubleshooting



**Caution** Be sure to turn off the power switch before connecting or disconnecting connectors, or parts may be damaged.

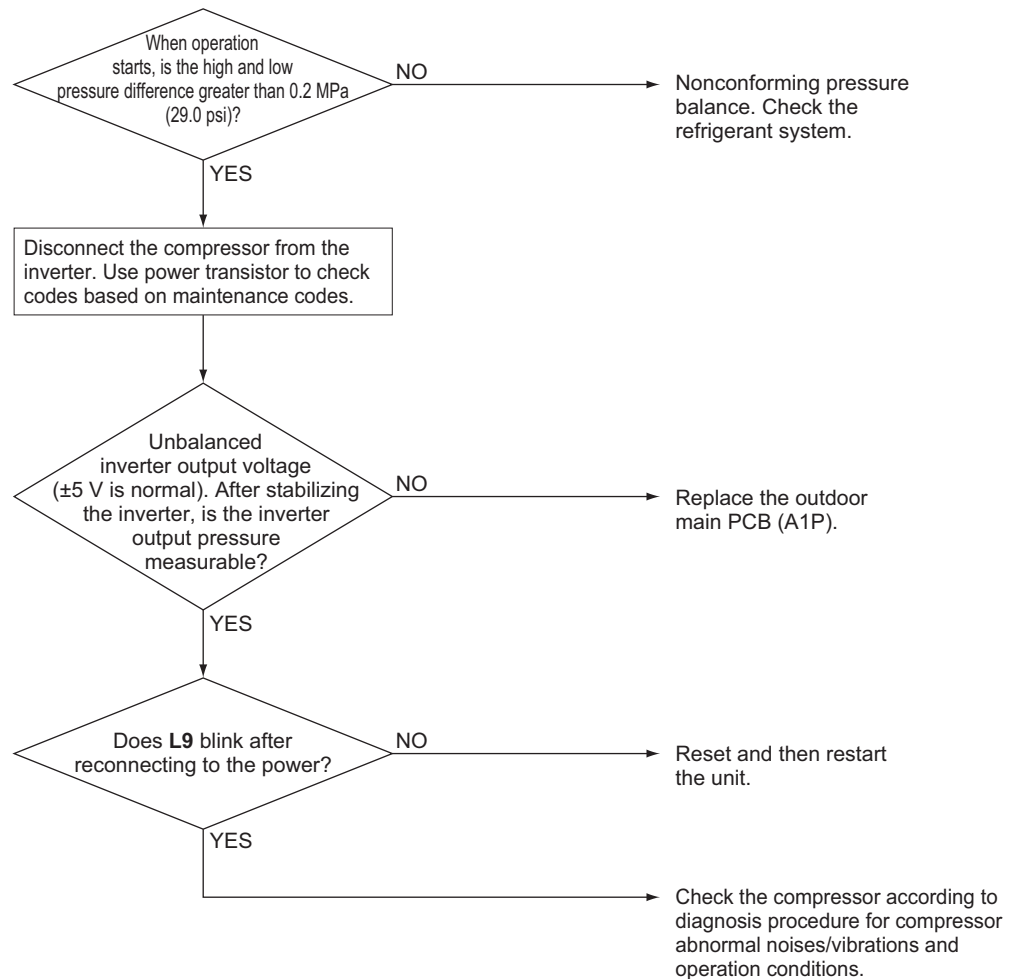

## 5.45 Transmission Error between Microcomputers on Outdoor Unit Main PCB

<b>Applicable Models</b>	All outdoor unit models
<b>Error Code</b>	<b>LC</b>
<b>Method of Error Detection</b>	Transmission conditions between microcomputers on the outdoor main PCB are tested via microcomputer.
<b>Error Decision Conditions</b>	No normal transmission after a certain period of time
<b>Supposed Causes</b>	<ul style="list-style-type: none"> <li>■ Connection error between microcomputers on the outdoor main PCB</li> <li>■ Defective outdoor main PCB (Transmission part)</li> <li>■ Defective noise filter</li> <li>■ External factors (Noise, etc.)</li> <li>■ Defective inverter compressor</li> <li>■ Defective fan motor</li> </ul>

### Troubleshooting

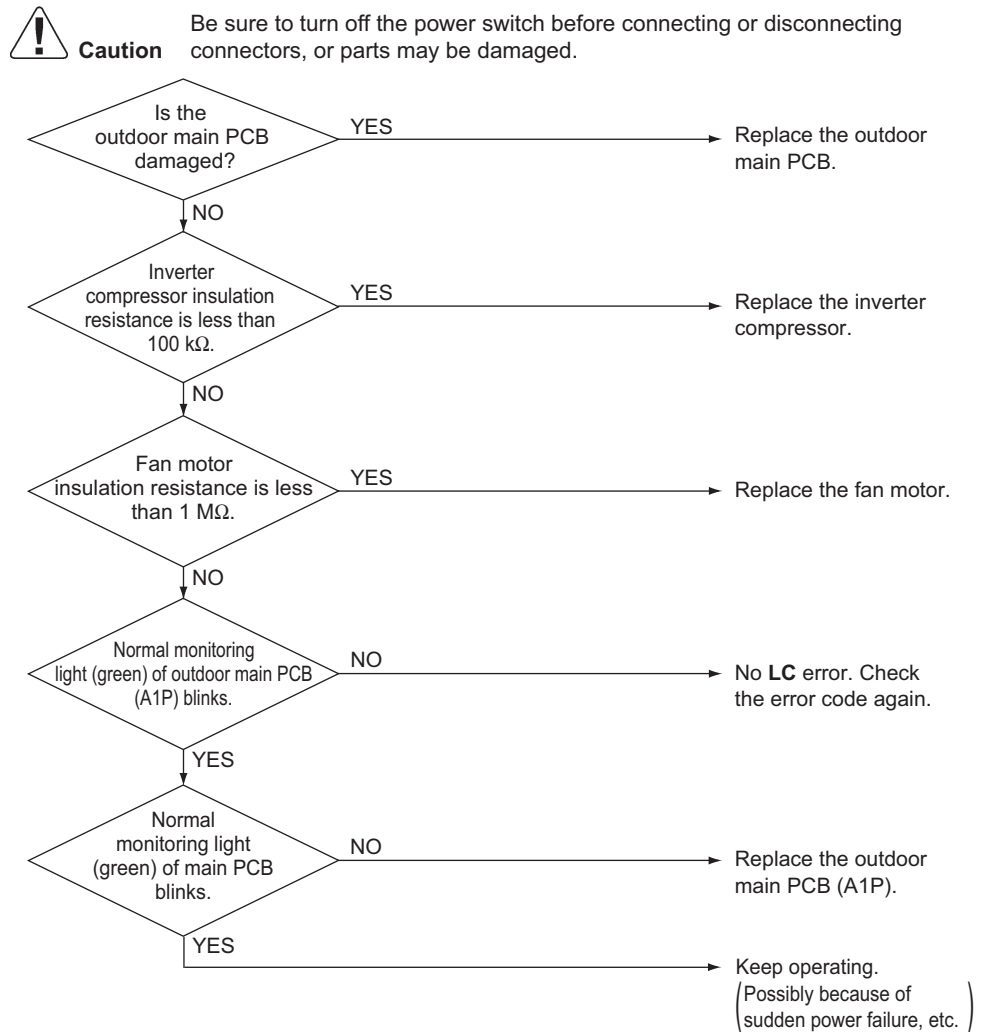

## 5.46 Inverter Circuit Capacitor High Voltage

<b>Applicable Models</b>	All outdoor unit models
<b>Error Code</b>	<b>P1</b>
<b>Method of Error Detection</b>	The voltage waveform of the main circuit capacitor of the inverter is used to check for errors.
<b>Error Decision Conditions</b>	The above-mentioned voltage waveform looks like the waveform of the power supply with a missing phase
<b>Supposed Causes</b>	<ul style="list-style-type: none"> <li>■ Defective main circuit capacitor</li> <li>■ Incorrect main circuit wiring</li> <li>■ Defective outdoor unit PCB</li> <li>■ Unbalanced voltage between phases</li> <li>■ Missing phase</li> </ul>

### Troubleshooting

**Caution**

Be sure to turn off the power switch before connecting or disconnecting connectors, or parts may be damaged.

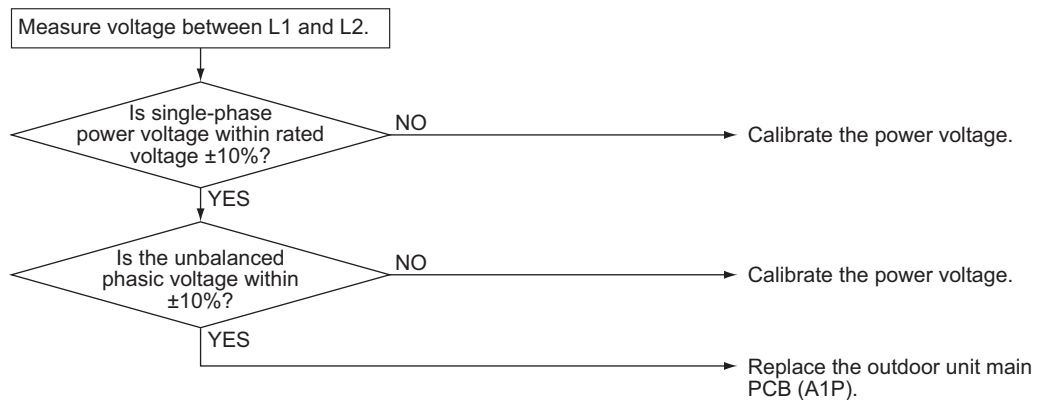

## 5.47 Radiation Fin Thermistor Abnormality

<b>Applicable Models</b>	All outdoor unit models
<b>Error Code</b>	<b>P4</b>
<b>Method of Error Detection</b>	Resistance of the following thermistor is detected when the compressor is not operating. (1) Radiation fin thermistor (2) PCB circuit thermistor
<b>Error Decision Conditions</b>	When the resistance value of thermistor becomes a value equivalent to open circuited or short circuited status * Error is not decided while the unit operation is continued. <b>P4</b> will be displayed by pressing the inspection button.
<b>Supposed Causes</b>	<ul style="list-style-type: none"> <li>■ Defective radiation fin temperature thermistor</li> <li>■ Defective PCB</li> <li>■ Defective inverter compressor</li> <li>■ Defective fan motor</li> </ul>

### Troubleshooting



**Caution**

Be sure to turn off the power switch before connecting or disconnecting connectors, or parts may be damaged.

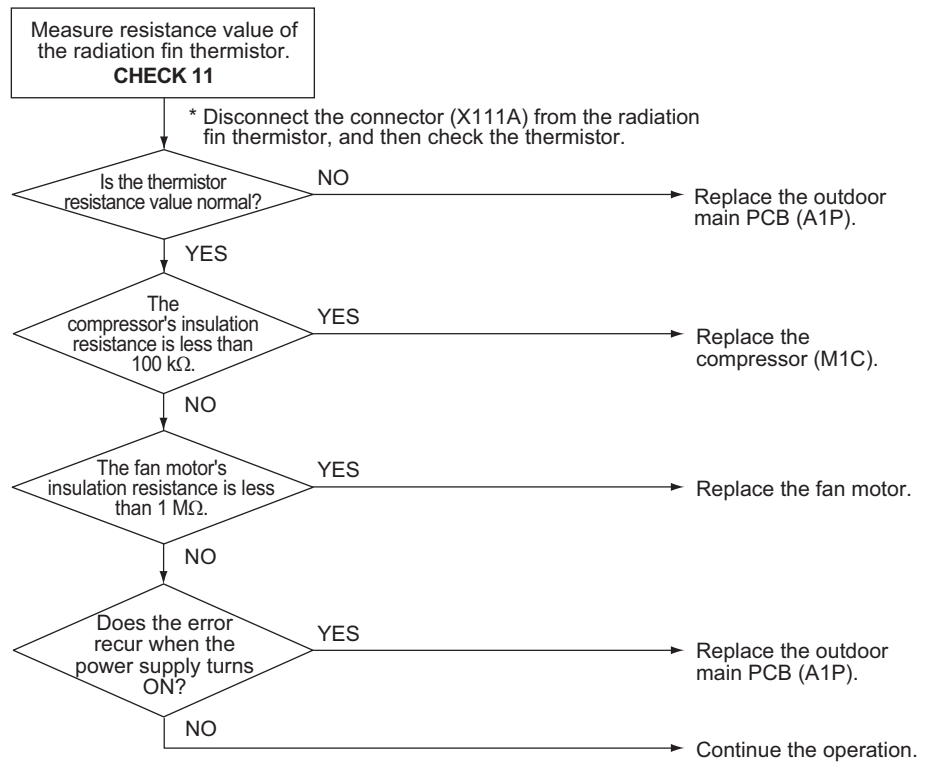

**Reference**

**CHECK 11** Refer to page 320.



## 5.48 Refrigerant Shortage

---

<b>Applicable Models</b>	All outdoor unit models
<b>Error Code</b>	<b>U0</b>
<b>Method of Error Detection</b>	Refrigerant shortage check is conducted based on the discharge pipe thermistor temperature and the low-pressure saturated temperature.
<b>Error Decision Conditions</b>	Microcomputer is used to determine and check for system refrigerant shortage. *The unit can keep operating but there is an unconfirmed error.
<b>Supposed Causes</b>	<ul style="list-style-type: none"><li>■ Refrigerant shortage or refrigerant clogging (piping error)</li><li>■ Defective suction pipe thermistor</li><li>■ Defective pressure sensor</li><li>■ Defective outdoor main PCB (A1P)</li></ul>

Troubleshooting



**Caution** Be sure to turn off the power switch before connecting or disconnecting connectors, or parts may be damaged.

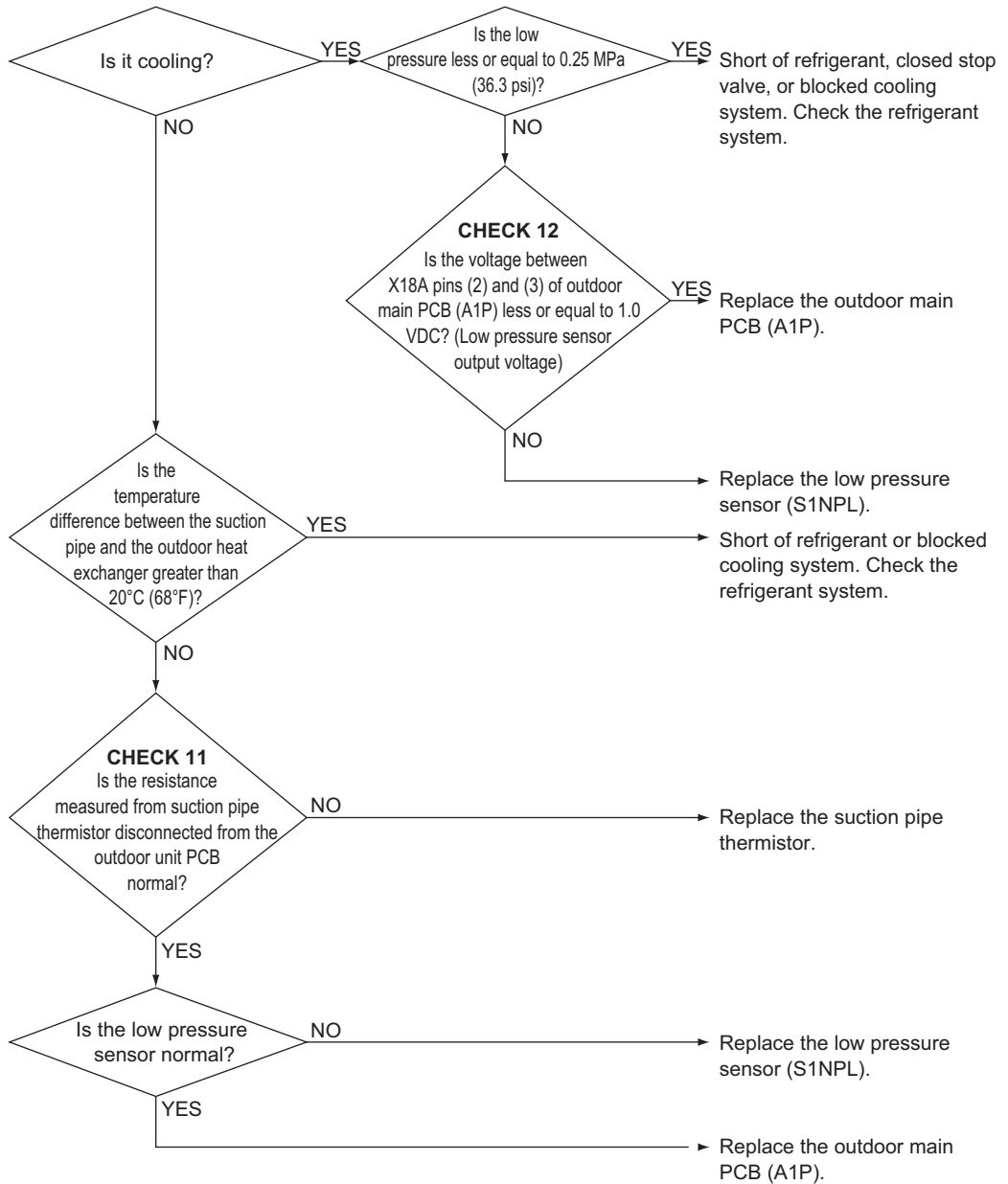

**Reference** CHECK 11 Refer to page 320.



**Reference** CHECK 12 Refer to page 323.

## 5.49 Power Supply Insufficient or Instantaneous Abnormality

---

**Applicable Models**

All outdoor unit models

---

**Error Code**

**U2**

---

**Method of Error Detection**

The main circuit capacitor voltage of the inverter and the power supply voltage is checked.

---

**Error Decision Conditions**

The main circuit capacitor of the tested inverter has abnormal voltage or the power supply voltage is abnormal.

---

**Supposed Causes**

- Insufficient power supply
- Instantaneous power failure
- Defective outdoor fan motor
- Defective outdoor unit PCB

Troubleshooting



**Caution** Be sure to turn off the power switch before connecting or disconnecting connectors, or parts may be damaged.

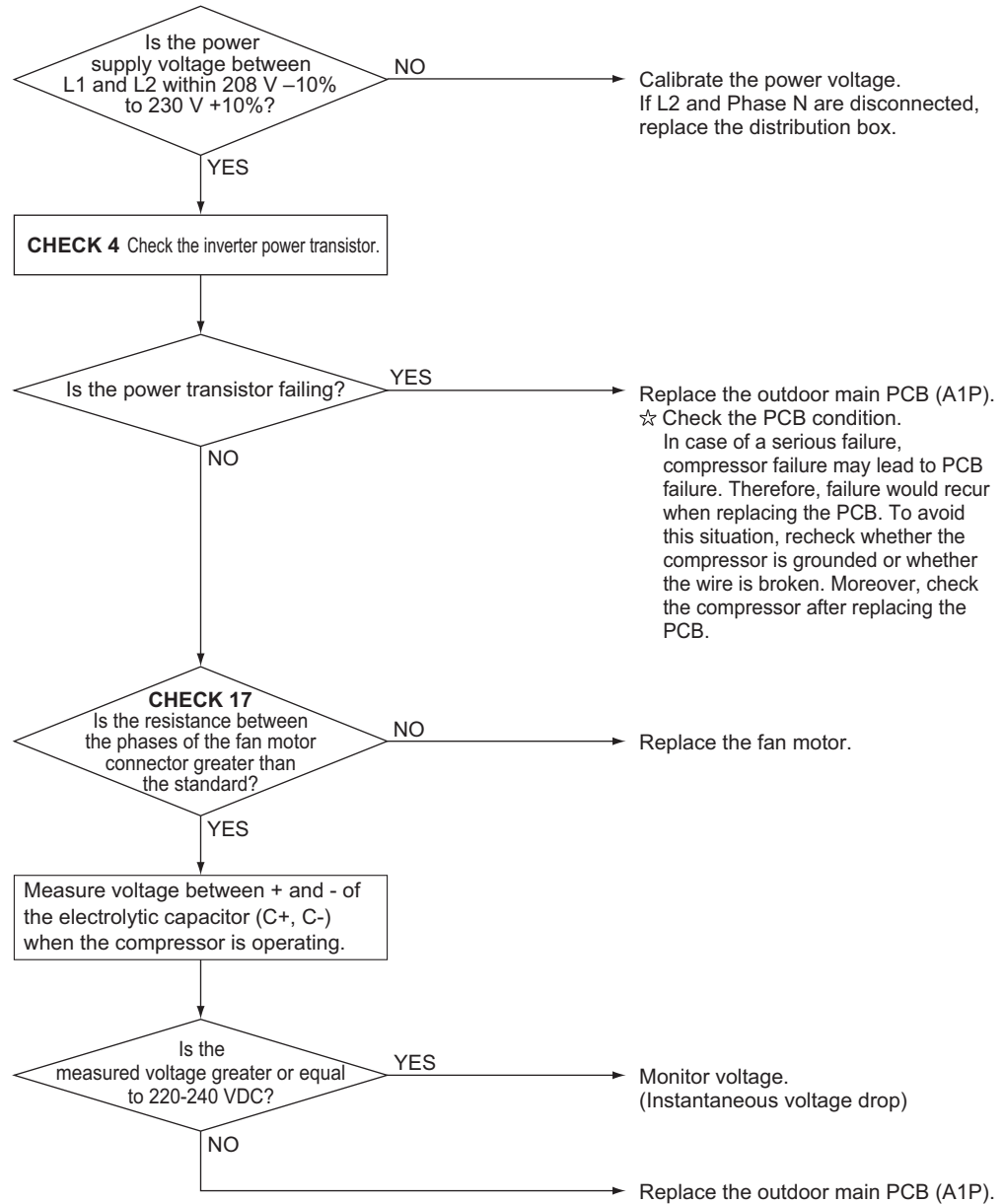

## 5.50 Check Operation Not Executed

**Applicable Models** All outdoor unit models

**Error Code** **U3**

**Method of Error Detection** Determined based on whether check operation is executed or not

**Error Decision Conditions** Error is decided when the unit starts operation without check operation.

**Supposed Causes** Check operation not executed

### Troubleshooting



**Caution**

Be sure to turn off the power switch before connecting or disconnecting connectors, or parts may be damaged.

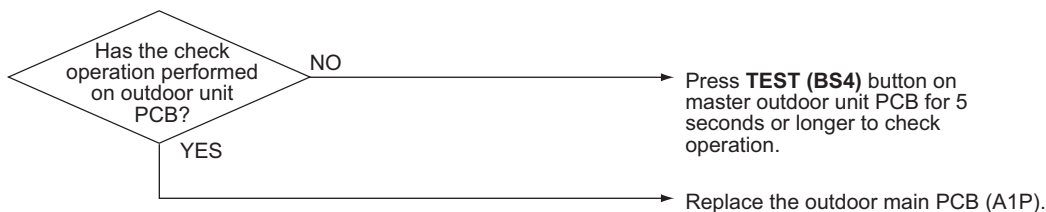

# 5.51 Transmission Error between Indoor Units and Outdoor Units

<b>Applicable Models</b>	All indoor unit models All outdoor unit models
<b>Error Code</b>	<b>U4</b>
<b>Method of Error Detection</b>	Microcomputer checks if transmission between indoor and outdoor units is normal.
<b>Error Decision Conditions</b>	When transmission is not carried out normally for a certain amount of time
<b>Supposed Causes</b>	<ul style="list-style-type: none"> <li>■ Indoor to outdoor transmission wiring F1, F2 disconnection, short circuit or wrong wiring</li> <li>■ Outdoor unit power supply is OFF</li> <li>■ System address does not match</li> <li>■ Defective indoor unit PCB</li> <li>■ Defective outdoor main PCB</li> </ul>

## Troubleshooting



**Caution**

Be sure to turn off the power switch before connecting or disconnecting connectors, or parts may be damaged.

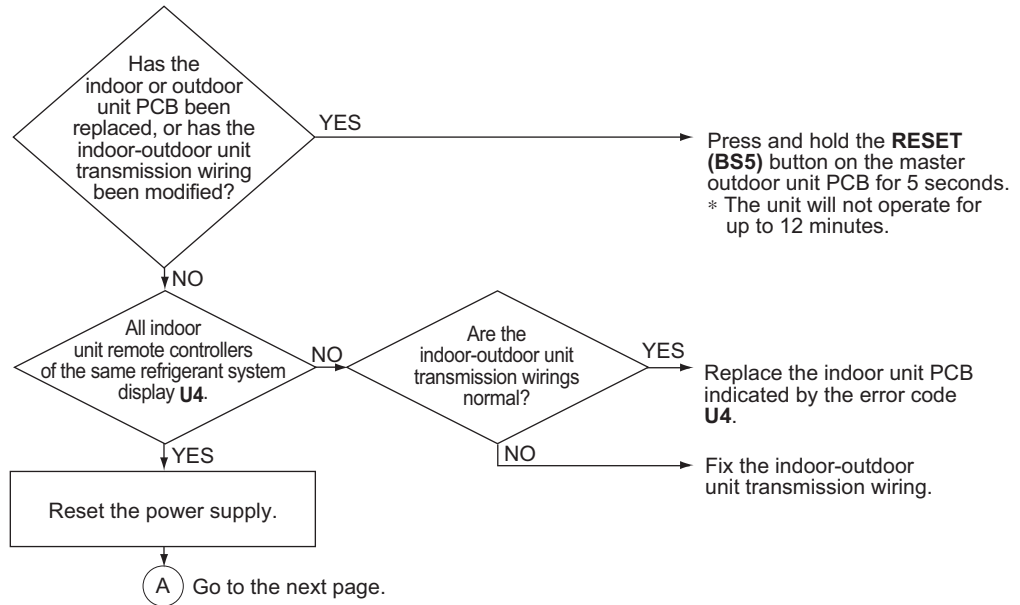

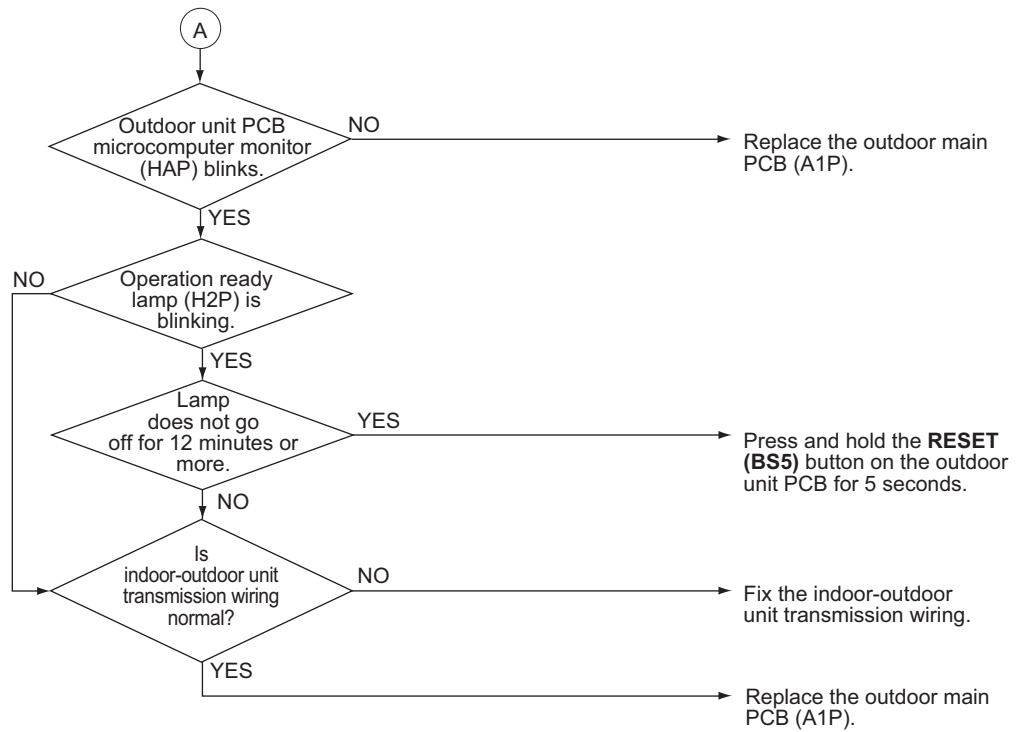

## 5.52 Transmission Error between Remote Controller and Indoor Unit

<b>Applicable Models</b>	All indoor unit models
<b>Error Code</b>	<b>U5</b>
<b>Method of Error Detection</b>	Microcomputer checks if transmission between indoor unit and remote controller is normal.
<b>Error Decision Conditions</b>	Transmission is not carried out normally for a certain amount of time.
<b>Supposed Causes</b>	<ul style="list-style-type: none"> <li>■ Transmission error between indoor unit and remote controller</li> <li>■ Connection of 2 main remote controllers (when using 2 remote controllers)</li> <li>■ Defective indoor unit control PCB</li> <li>■ Defective remote controller PCB</li> <li>■ Transmission error caused by noise</li> </ul>

### Troubleshooting

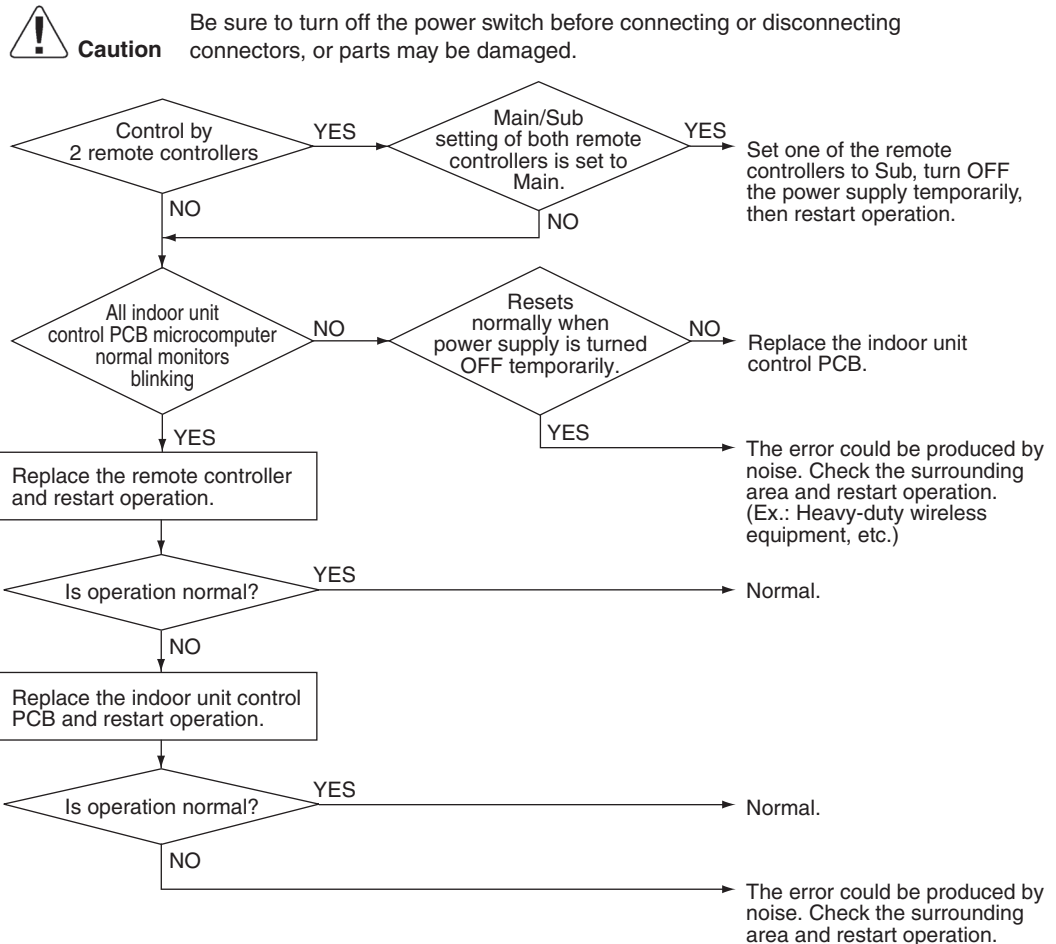

**Reference** Refer to page 61 for Main/Sub setting.



## 5.53 Transmission Error between Main and Sub Remote Controllers

<b>Applicable Models</b>	All indoor unit models
<b>Error Code</b>	<b>U8</b>
<b>Method of Error Detection</b>	In case of controlling with 2 remote controllers, check the system using microcomputer if signal transmission between indoor unit and remote controller (main and sub remote controller) is normal.
<b>Error Decision Conditions</b>	When transmission is not carried out normally for a certain amount of time.
<b>Supposed Causes</b>	<ul style="list-style-type: none"> <li>■ Transmission error between main and sub remote controller</li> <li>■ Connection between sub remote controllers</li> <li>■ Defective remote controller PCB</li> </ul>

### Troubleshooting

**Caution**

Be sure to turn off the power switch before connecting or disconnecting connectors, or parts may be damaged.

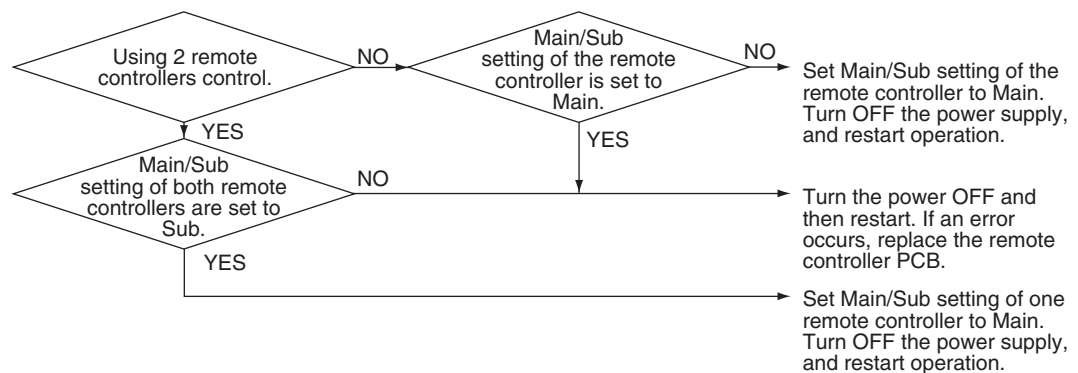
**Reference**

Refer to page 61 for Main/Sub setting.

## 5.54 Transmission Error between Indoor Units and Outdoor Units in the Same System

<b>Applicable Models</b>	All indoor unit models All outdoor unit models
<b>Error Code</b>	<b>U9</b>
<b>Method of Error Detection</b>	Error signal for the other indoor units is detected within the system by outdoor unit PCB.
<b>Error Decision Conditions</b>	The error decision is made on any other indoor unit within the system concerned.
<b>Supposed Causes</b>	<ul style="list-style-type: none"> <li>■ Transmission error within or outside of other system</li> <li>■ Defective electronic expansion valve in indoor unit of other system</li> <li>■ Defective PCB of indoor unit in other system</li> <li>■ Improper connection of transmission wiring between indoor and outdoor unit</li> </ul>

### Troubleshooting



**Caution**

Be sure to turn off the power switch before connecting or disconnecting connectors, or parts may be damaged.

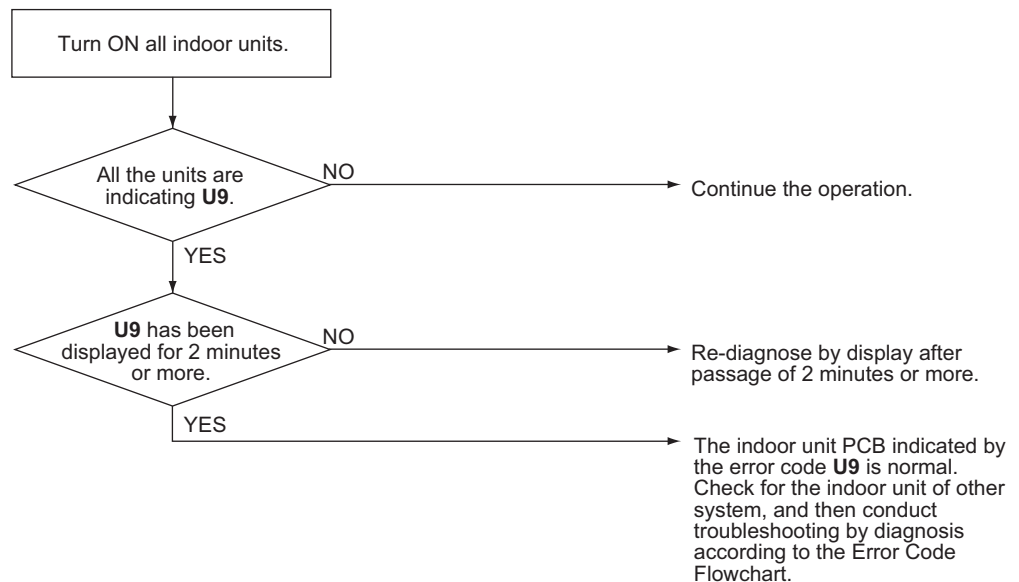

## 5.55 Improper Combination of Indoor and Outdoor Units, Indoor Units and Remote Controller

---

<b>Applicable Models</b>	All indoor unit models All outdoor unit models
<b>Error Code</b>	<b>UA</b>
<b>Method of Error Detection</b>	A difference occurs in data by the type of refrigerant between indoor and outdoor units. The number of indoor units is out of the allowable range.
<b>Error Decision Conditions</b>	The error decision is made as soon as either of the abnormalities aforementioned is detected.
<b>Supposed Causes</b>	<ul style="list-style-type: none"><li>■ Excess of connected indoor units</li><li>■ Defective outdoor main PCB</li><li>■ Mismatching of the refrigerant type of indoor and outdoor unit.</li><li>■ Setting of outdoor main PCB was not conducted after replacing to spare PCB.</li></ul>

---

Troubleshooting



**Caution** Be sure to turn off the power switch before connecting or disconnecting connectors, or parts may be damaged.

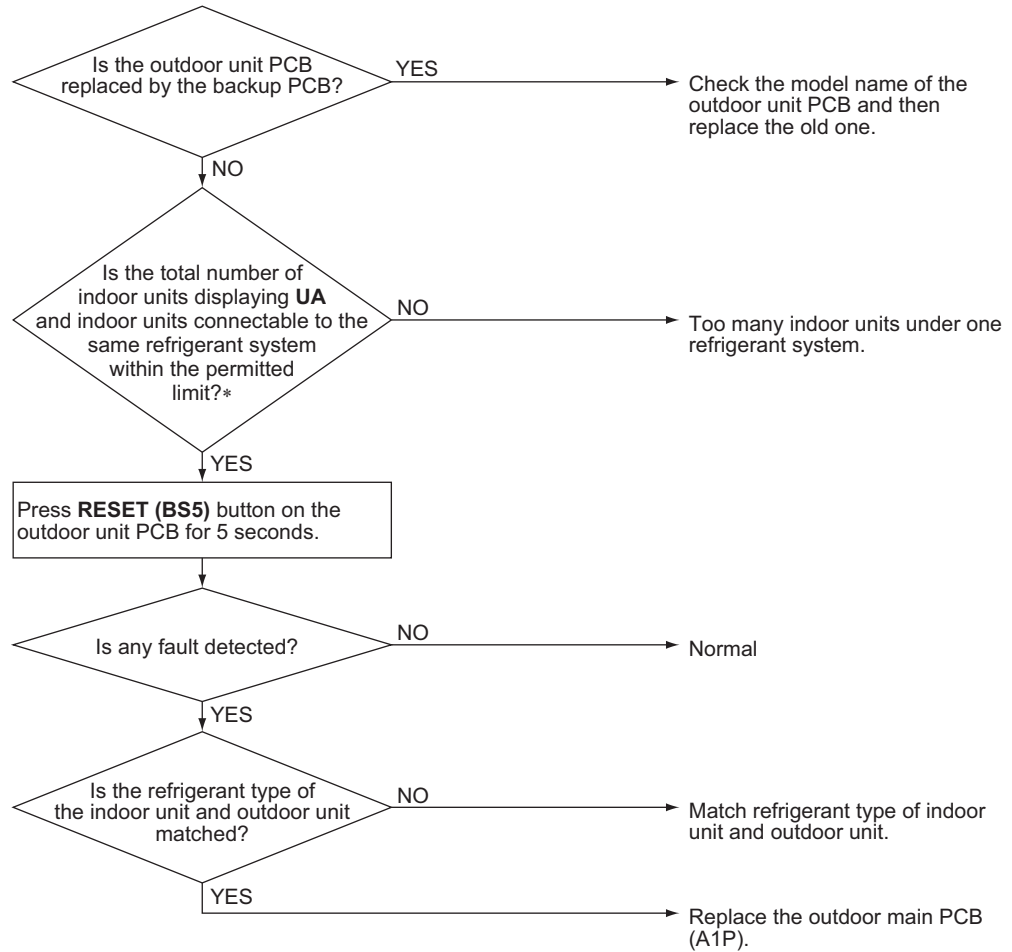

\* The number of indoor units that may be connected to an individual outdoor unit system is determined by the model of the outdoor unit.

## 5.56 Incorrect Gas Furnace Connecting Number

---

**Applicable Models**CXTQ-TA

---

**Error Code****UA**

---

**Outline**Two or more "CXTQ-TA + gas furnace" and other indoor units other than CXTQ-TA are connected.

---

**Error Decision Conditions**Check that two or more "CXTQ-TA + gas furnace" and other indoor units other than CXTQ-TA are not connected.

---

**Operation After Error Codes Decided**

- The error code **UA** is displayed on the remote controller.
- Change to be the system that one "CXTQ-TA + gas furnace" and other indoor units other than CXTQ-TA are connected.

## 5.57 Incorrect Electric Heater Capacity Setting

**Applicable Models**

FXTQ-TA

**Error Code**

**UA-17**

**Outline**

After attaching optional electric heater, if the electric heater capacity setting (11 (21)-5) is made mistakenly for heaters not featured in the lineup, heating via unintended levels of airflow will be prevented.  
However, the electric heater will be operable for convenience.

**Error Decision Conditions**

Checks when the capacity setting (11 (21)-5) of the electric heater has been set to a non-applicable value.

**Operation After Error Codes Decided**

- The error code **UA-17** is displayed on the remote controller.
- Indoor units can operate continuously.
- Incorrect setting is kept.
- Even if the ON condition for electric heater 2 is established, only electric heater 1 will be set to ON.  
(Electric heater 1 set to ON, electric heater 2 set to OFF)  
(In order to deliver in terms of user-friendliness and safety, the electric heater can operate at the lowest possible power levels.)
- The airflow of the fan during operation of the electric heater will be set to the largest value within the CFM dictated by the capacity of each of the electric heaters (electric heater 1, electric heater 2 both set to ON).
- All other operations are the same as during normal operation.

## 5.58 Address Duplication of Centralized Controller

<b>Applicable Models</b>	All indoor unit models Centralized controller
<b>Error Code</b>	<b>UC</b>
<b>Method of Error Detection</b>	The principal indoor unit detects the same address as that of its own on any other indoor unit.
<b>Error Decision Conditions</b>	The error decision is made as soon as the abnormality aforementioned is detected.
<b>Supposed Causes</b>	<ul style="list-style-type: none"> <li>■ Address duplication of centralized controller</li> <li>■ Defective indoor unit PCB</li> </ul>
<b>Troubleshooting</b>	<div style="text-align: center;">  <p><b>Caution</b> Be sure to turn off the power switch before connecting or disconnecting connectors, or parts may be damaged.</p> </div> <pre> graph TD     Q{Does the optional remote controller for centralized controller connect to the indoor unit?}     Q -- YES --&gt; A[Address duplication on the centralized controller. Change the setting to avoid centralized controller address duplication.]     Q -- NO --&gt; B[Replace the indoor unit PCB.]           </pre>



**Caution**

Be sure to turn off the power switch before connecting or disconnecting connectors, or parts may be damaged.

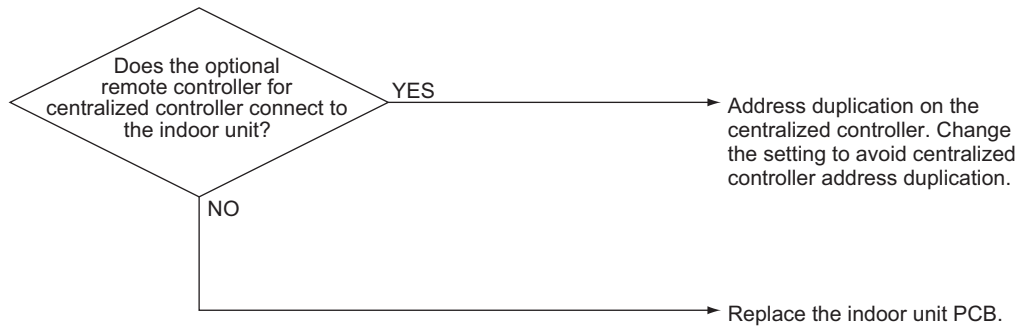

## 5.59 Transmission Error between Centralized Controller and Indoor Unit

<b>Applicable Models</b>	All indoor unit models Centralized controller Schedule timer intelligent Touch Controller
<b>Error Code</b>	<b>UE</b>
<b>Method of Error Detection</b>	Microcomputer checks if transmission between indoor unit and centralized controller is normal.
<b>Error Decision Conditions</b>	When transmission is not carried out normally for a certain amount of time
<b>Supposed Causes</b>	<ul style="list-style-type: none"> <li>■ Transmission error between optional controllers for centralized controller and indoor unit</li> <li>■ Connector for setting main controller is disconnected. (or disconnection of connector for independent / combined use changeover switch.)</li> <li>■ Defective PCB for centralized controller</li> <li>■ Defective indoor unit PCB</li> </ul>



## Troubleshooting

**Caution**

Be sure to turn off the power switch before connecting or disconnecting connectors, or parts may be damaged.

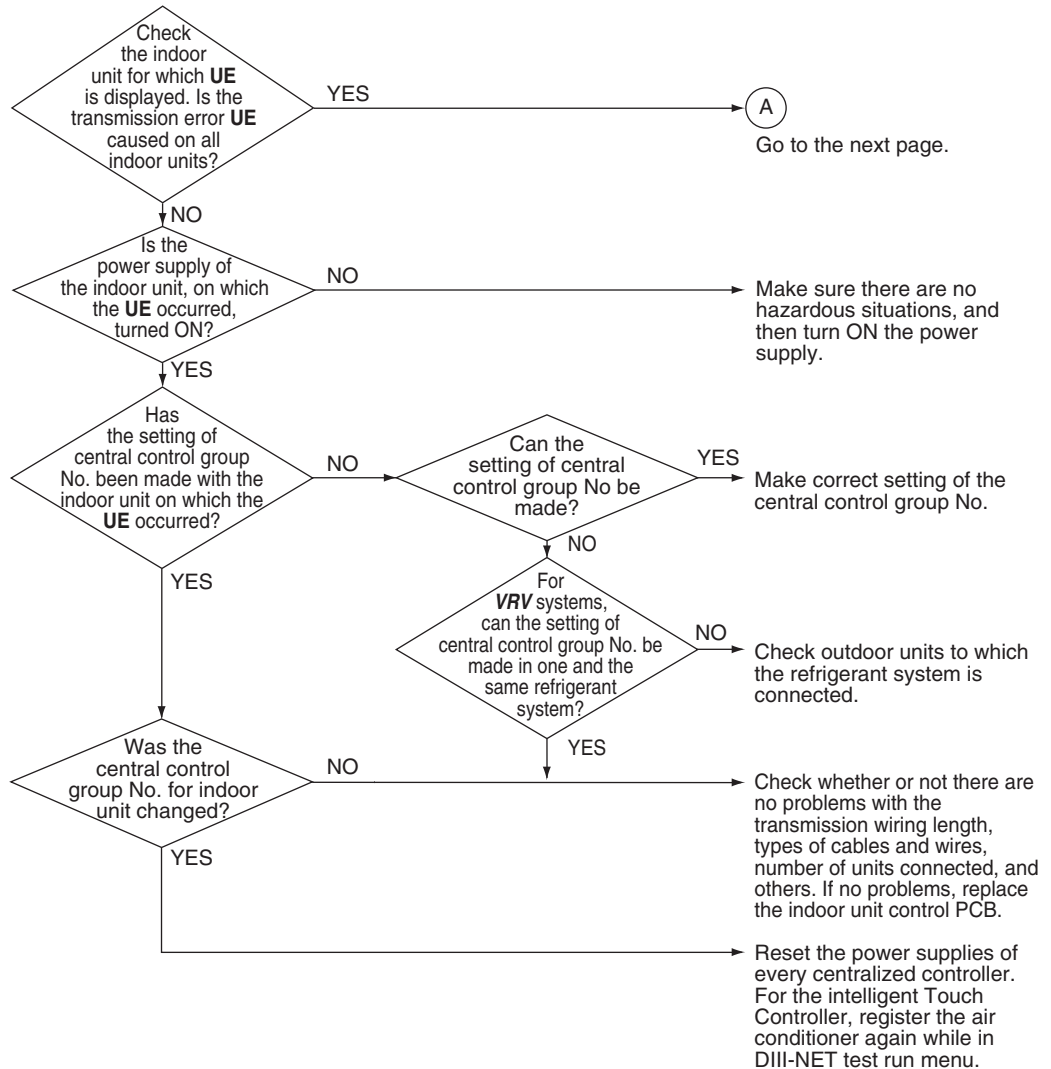

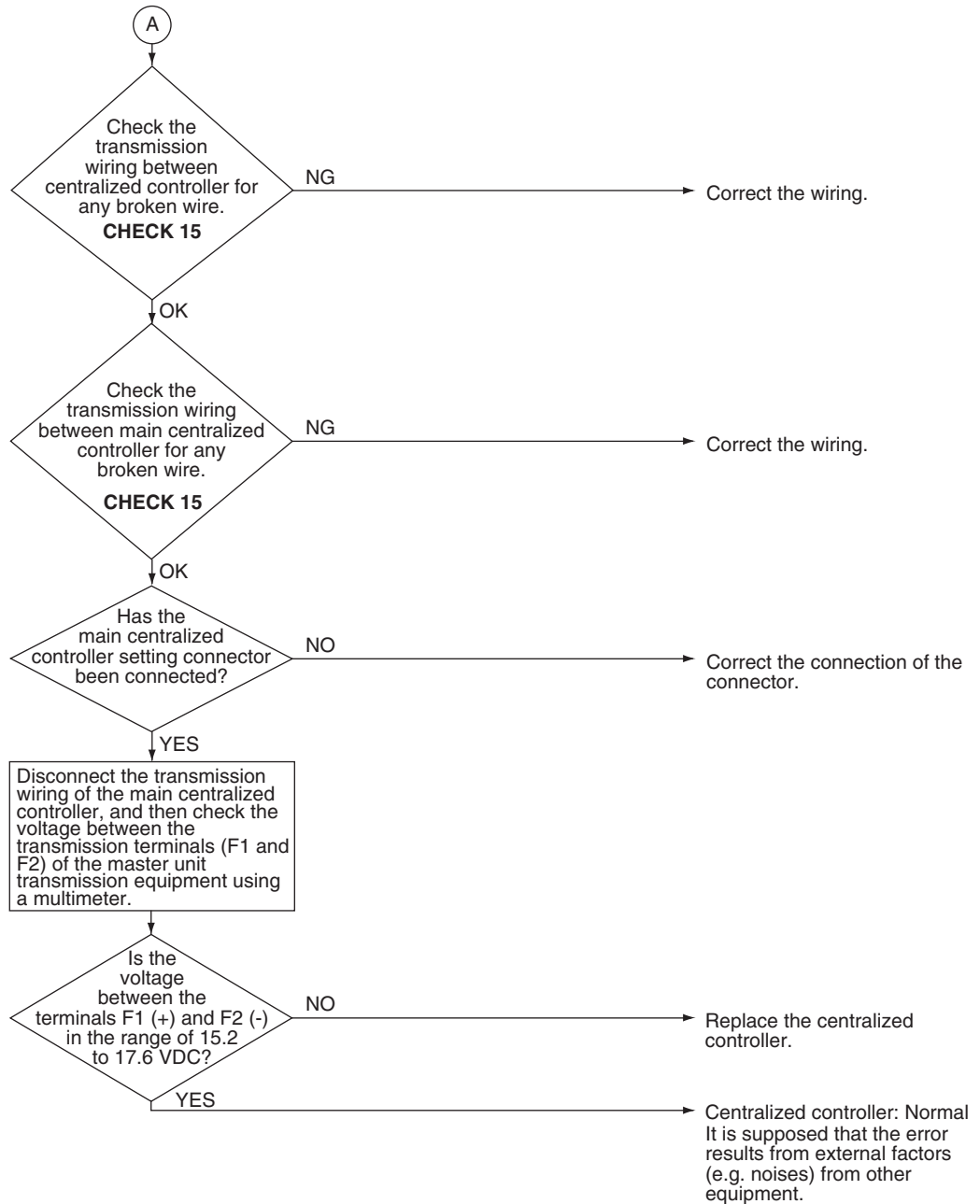

Reference

**CHECK 15** Refer to page 325.

## 5.60 System Not Set Yet

<b>Applicable Models</b>	All indoor unit models All outdoor unit models
<b>Error Code</b>	<b>UF</b>
<b>Method of Error Detection</b>	On check operation, the number of indoor units in terms of transmission is not corresponding to that of indoor units that have made changes in temperature.
<b>Error Decision Conditions</b>	The error is determined as soon as the abnormality aforementioned is detected through checking the system for any erroneous connection of units on the check operation.
<b>Supposed Causes</b>	<ul style="list-style-type: none"> <li>■ Improper connection of transmission wiring between indoor-outdoor units</li> <li>■ Failure to execute check operation</li> <li>■ Defective indoor unit PCB</li> <li>■ Stop valve is not opened</li> </ul>

### Troubleshooting

**Caution**

Be sure to turn off the power switch before connecting or disconnecting connectors, or parts may be damaged.

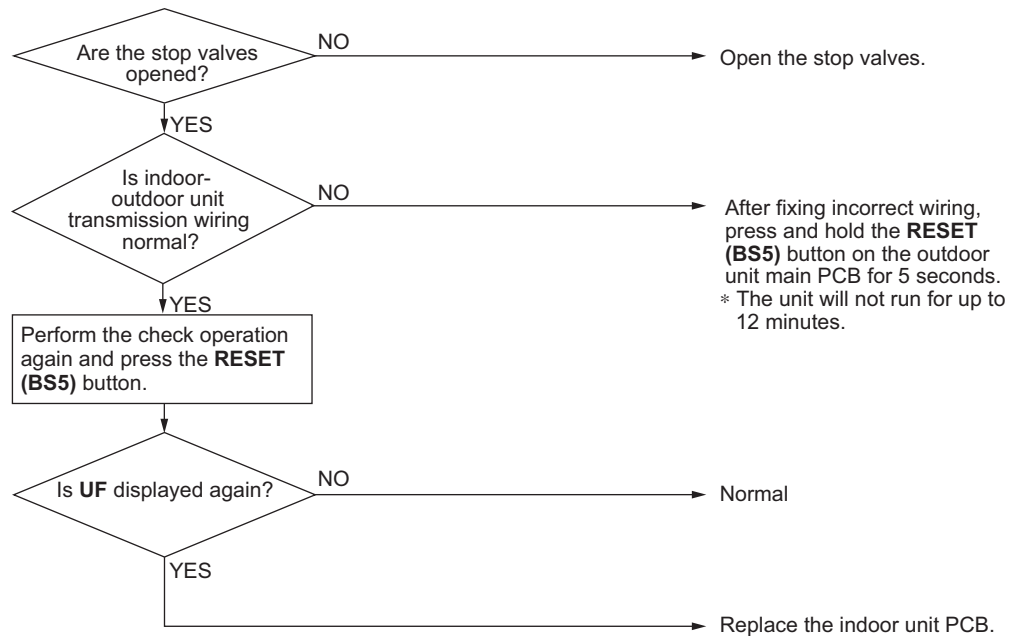

## 5.61 System Abnormality, Refrigerant System Address Undefined

<b>Applicable Models</b>	All indoor unit models All outdoor unit models
<b>Error Code</b>	<b>UH</b>
<b>Method of Error Detection</b>	System detects an indoor unit whose address is not defined by automatic address function. * Automatic address refers to the automatic designated address of indoor unit and outdoor unit when connected to the power after installation or wiring replacement (with the <b>RESET (BS5)</b> button pressed for more than 5 seconds).
<b>Error Decision Conditions</b>	The error decision is made as soon as the abnormality aforementioned is detected.
<b>Supposed Causes</b>	<ul style="list-style-type: none"> <li>■ Improper connection of transmission wiring between indoor-outdoor units</li> <li>■ Defective indoor unit PCB</li> <li>■ Defective outdoor unit main PCB (A1P)</li> </ul>

### Troubleshooting



**Caution**

Be sure to turn off the power switch before connecting or disconnecting connectors, or parts may be damaged.

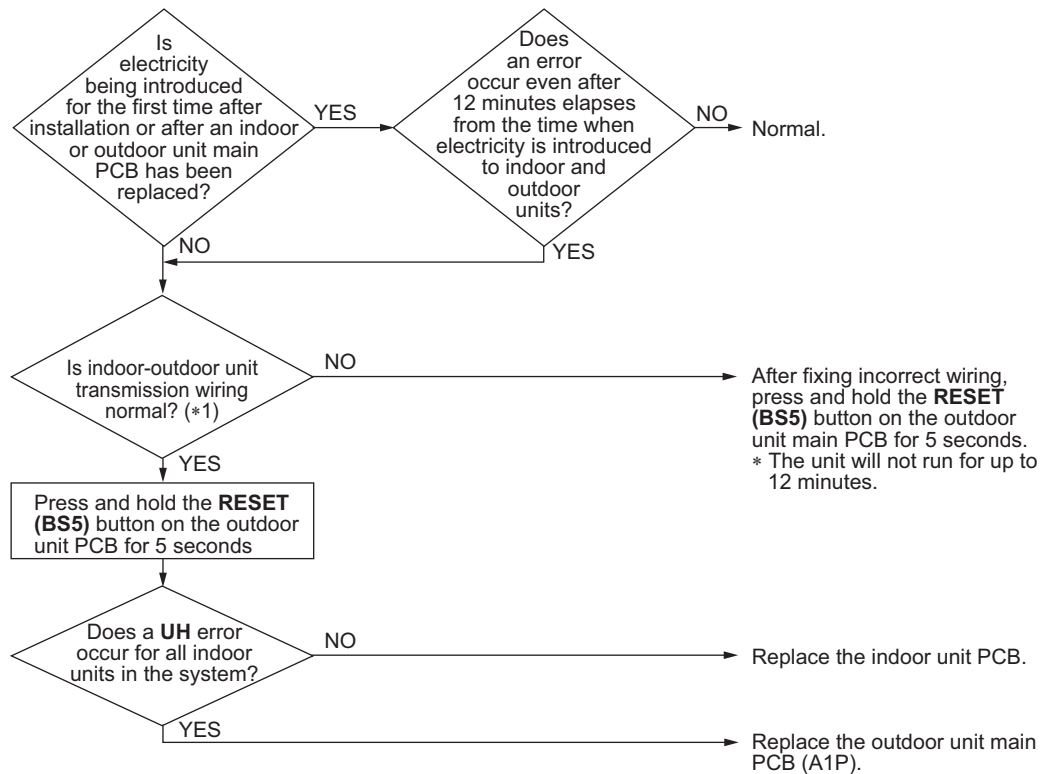

**Note(s)**

\*1. Refer to installation manual for correct "indoor unit and outdoor unit connection wiring".

## 5.62 Climate Talk Communication System Combination Error (Before Initial Setting for Communication Completes)

<b>Applicable Models</b>	CXTQ-TA
<b>Error Code</b>	<b>UH-05</b>
<b>Method of Error Detection</b>	Detects the type of the devices constituted in Climate Talk Communication.
<b>Error Decision Conditions</b>	<p>The error decision is made when any of the following conditions is established before elapsing 4 minutes after the power is turned ON.</p> <ul style="list-style-type: none"> <li>■ Two or more gas furnaces are detected.</li> <li>■ Any unit other than the gas furnace is detected.</li> <li>■ The initial setting for communication does not complete.</li> </ul>
<b>Supposed Causes</b>	<ul style="list-style-type: none"> <li>■ Connection of wrong devices</li> <li>■ The power of the gas furnace is not turned ON, or the power of the gas furnace is turned ON after a certain period of time has been elapsed after the power of the CXTQ-TA was turned ON.</li> <li>■ Disconnection of the communication wire between the CXTQ-TA and the gas furnace</li> <li>■ Two or more gas furnaces are connected to one CXTQ-TA.</li> <li>■ No gas furnace is connected.</li> </ul>

### Troubleshooting

**Caution**

Be sure to turn off the power switch before connecting or disconnecting connectors, or parts may be damaged.

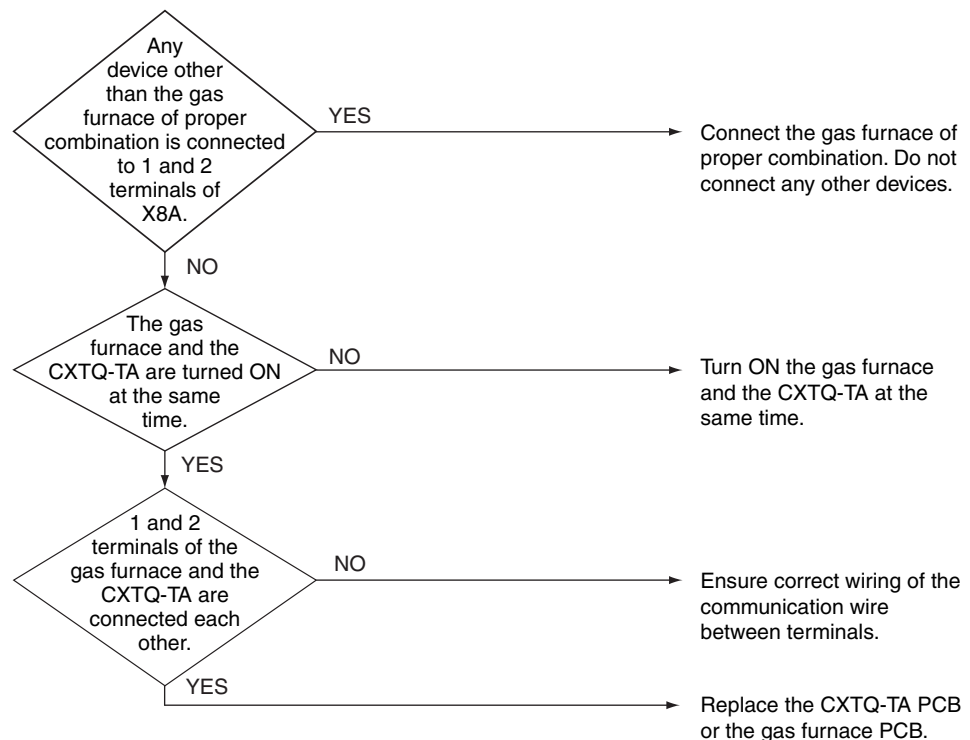

## 5.63 Climate Talk Communication System Combination Error (After Initial Setting for Communication Completes)

<b>Applicable Models</b>	CXTQ-TA
<b>Error Code</b>	<b>UH-06</b>
<b>Method of Error Detection</b>	Detects the type of the devices constituted in Climate Talk Communication.
<b>Error Decision Conditions</b>	<p>The error decision is made when any of the following conditions is established once the initial setting for communication with the gas furnace completes and after elapsing 4 minutes after the power is turned ON.</p> <ul style="list-style-type: none"> <li>■ Two or more gas furnaces are detected.</li> <li>■ Any unit other than the gas furnace is detected.</li> </ul>
<b>Supposed Causes</b>	<ul style="list-style-type: none"> <li>■ Connection of wrong devices</li> <li>■ Two or more gas furnaces are connected to one CXTQ-TA.</li> </ul>

### Troubleshooting



**Caution**

Be sure to turn off the power switch before connecting or disconnecting connectors, or parts may be damaged.

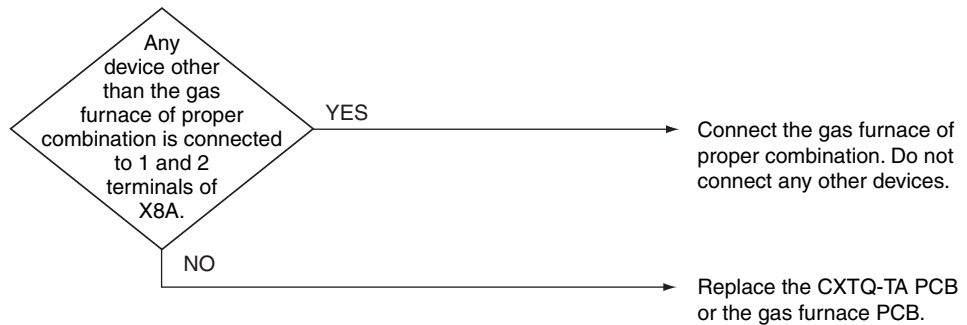

## 5.64 Defective PCB

<b>Applicable Models</b>	Centralized controller intelligent Touch Controller Schedule timer
<b>Error Code</b>	<b>M1</b>
<b>Method of Error Detection</b>	DIII-NET polarity circuit defective conditions are used to detect the error.
<b>Error Decision Conditions</b>	The test detects both positive polarity and negative polarity.
<b>Supposed Causes</b>	<ul style="list-style-type: none"> <li>■ Defective centralized controller PCB</li> <li>■ Defective intelligent touch controller PCB</li> <li>■ Defective schedule timer PCB</li> </ul>
<b>Troubleshooting</b>	

**Caution**

Be sure to turn off the power switch before connecting or disconnecting connectors, or parts may be damaged.

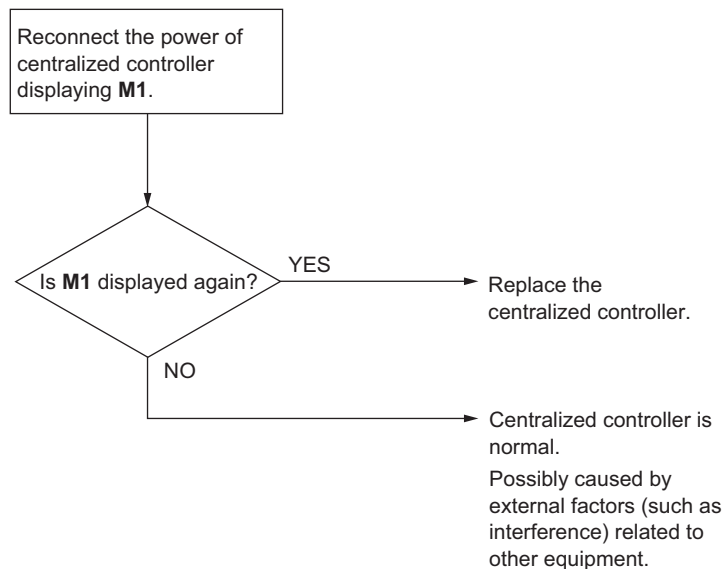

## 5.65 Transmission Error (between Centralized Controllers)

---

**Applicable Models**

Centralized controller  
intelligent Touch Controller  
Schedule timer

---

**Error Code**

**M8**

---

**Method of Error Detection**

DIII-NET communication data is used to detect the error. (Automatic reset)

---

**Error Decision Conditions**

When the sub centralized controller is activated, there is no main centralized controller.  
The previously connected centralized controller is not responding.

---

**Supposed Causes**

- Transmission defect between centralized controllers
- Defective centralized controller PCB



Troubleshooting



**Caution**

Be sure to turn off the power switch before connecting or disconnecting connectors, or parts may be damaged.

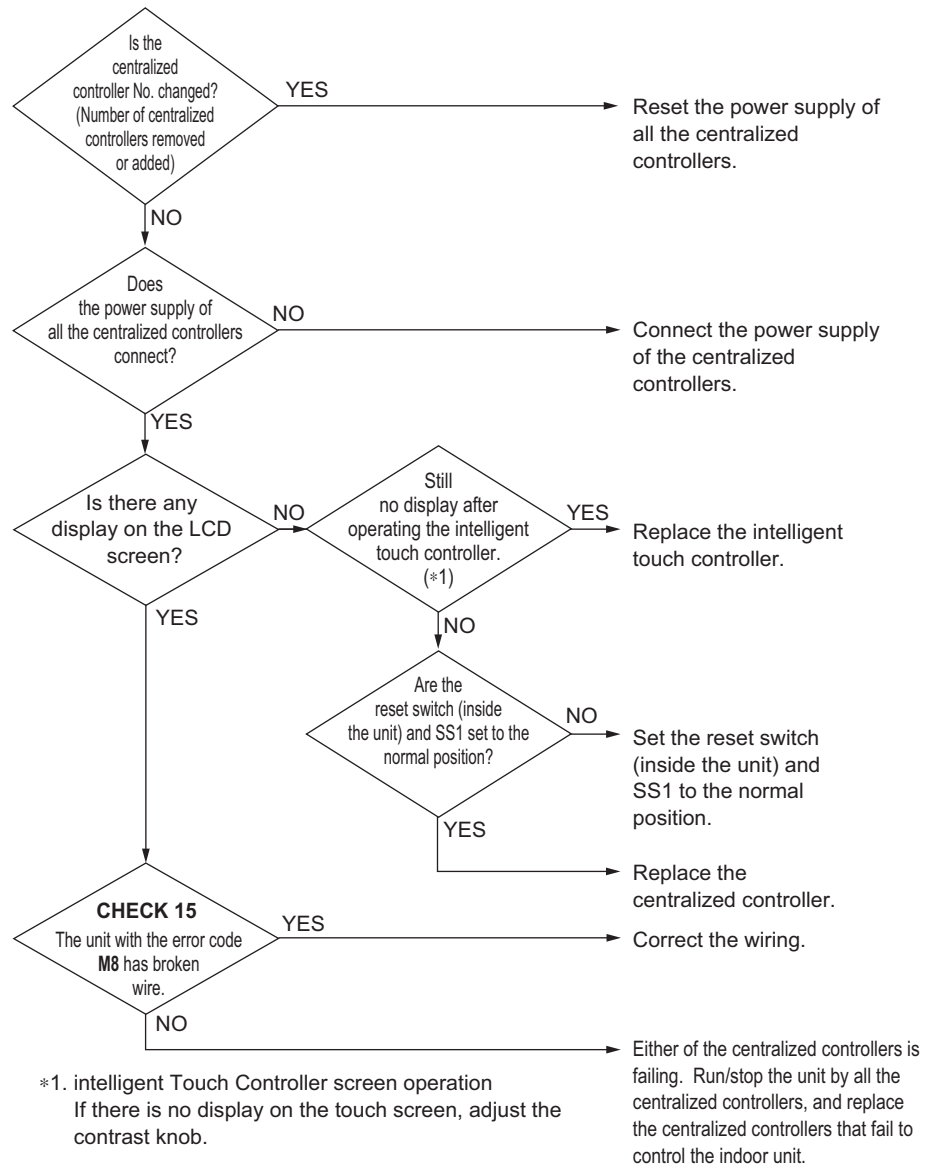

Reference

**CHECK 15** Refer to page 325.

## 5.66 Poor Centralized Controller Combination

<b>Applicable Models</b>	Centralized controller intelligent Touch Controller Schedule timer
<b>Error Code</b>	<b>MA</b>
<b>Method of Error Detection</b>	DIII-NET communication data is used to detect the error.
<b>Error Decision Conditions</b>	There are other centralized controllers but the schedule timer is set for individual use. There are multiple main centralized controllers. There is a remote control adaptor.
<b>Supposed Causes</b>	<ul style="list-style-type: none"> <li>■ Poor centralized controller combination</li> <li>■ Multiple main centralized controllers</li> <li>■ Defective centralized controller PCB</li> </ul>

Troubleshooting



**Caution**

Be sure to turn off the power switch before connecting or disconnecting connectors, or parts may be damaged.

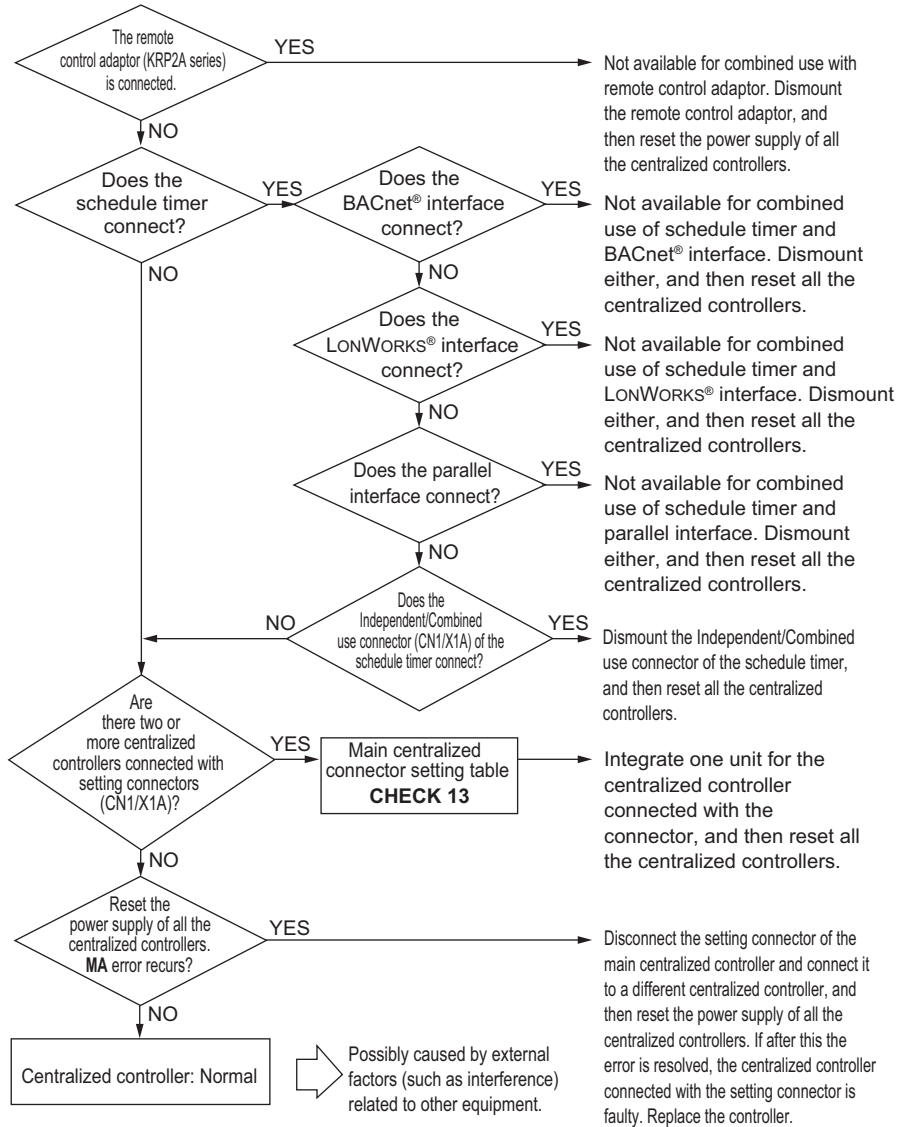

**Reference**

**CHECK 13** Refer to page 324.

## 5.67 Address Duplication, Poor Setting

<b>Applicable Models</b>	Centralized controller intelligent Touch Controller Schedule timer
<b>Error Code</b>	<b>MC</b>
<b>Method of Error Detection</b>	DIII-NET communication data is used to detect the error.
<b>Error Decision Conditions</b>	Multiple centralized controllers or intelligent touch controllers are connected, and the controllers are both set as main centralized controllers or sub centralized controllers. Two schedule timers are connected.
<b>Supposed Causes</b>	<ul style="list-style-type: none"> <li>■ Centralized controller address duplication</li> </ul>

Troubleshooting

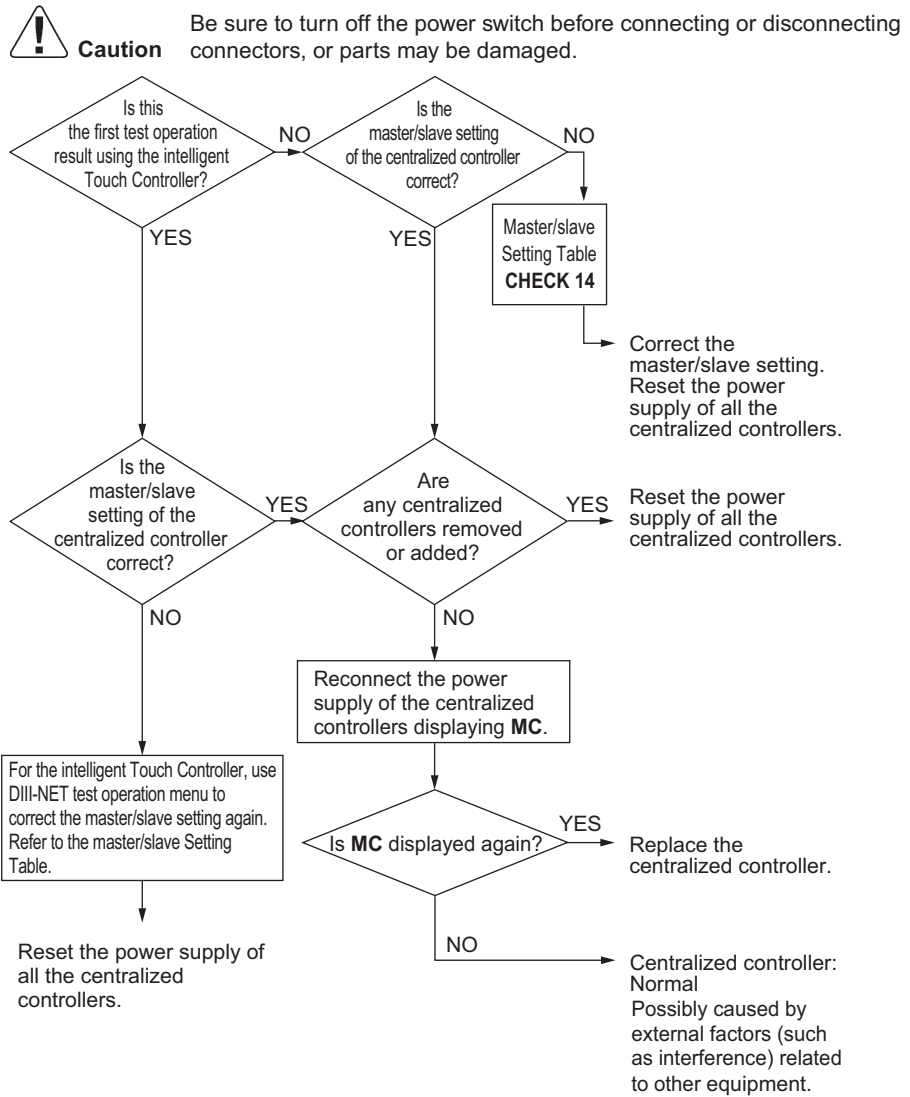

 **Reference** CHECK 14 Refer to page 325.

## 5.68 Operation Lamp Blinking

<b>Applicable Models</b>	ON/OFF controller Indoor unit
<b>Error Code</b>	—
<b>Method of Error Detection</b>	DIII-NET communication data is used to detect the error.
<b>Error Decision Conditions</b>	—
<b>Supposed Causes</b>	<ul style="list-style-type: none"> <li>■ Defective transmission between the centralized controller and an indoor unit</li> <li>■ Loosened setting connector of the main centralized controller</li> <li>■ Defective ON/OFF controller PCB</li> <li>■ Defective indoor unit PCB</li> <li>■ Defective air conditioner</li> </ul>

### Troubleshooting

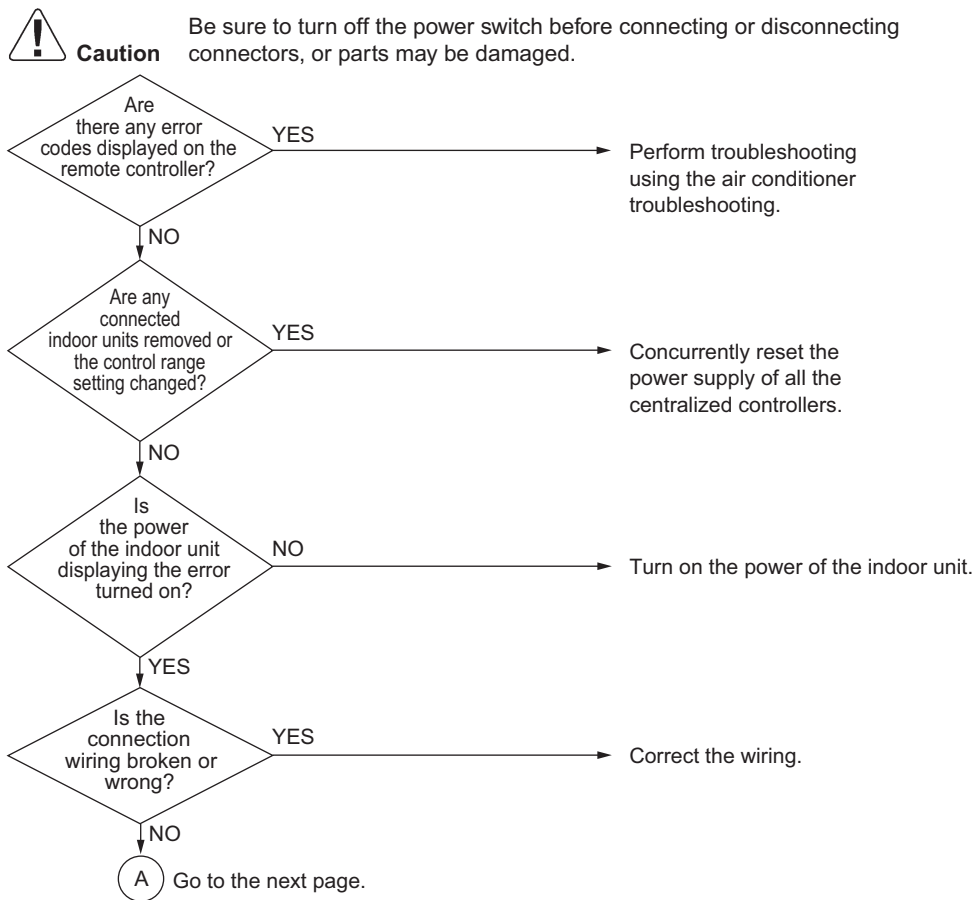

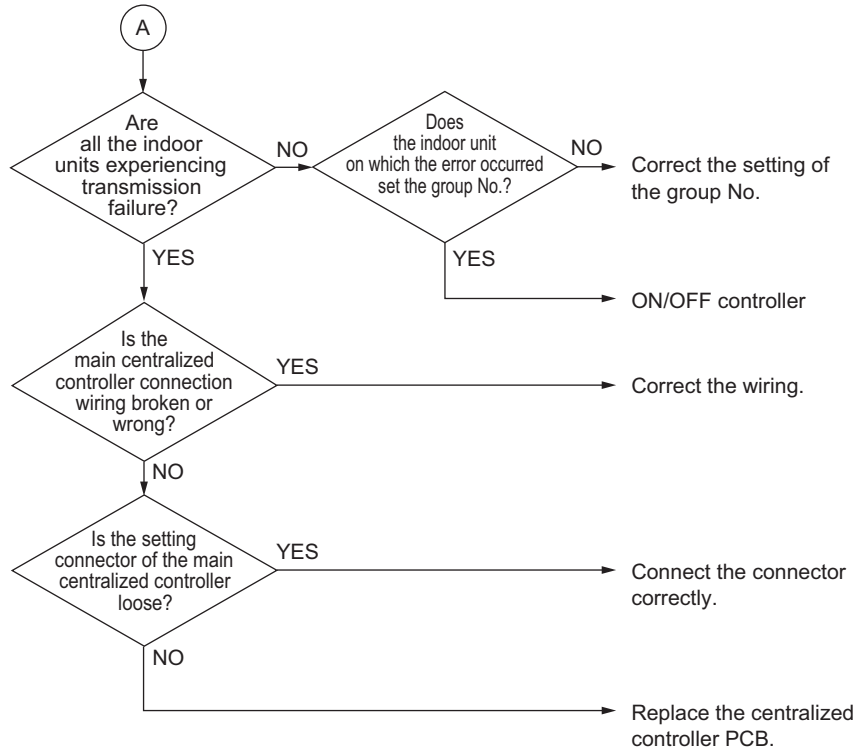

## 5.69 Central Control Indicator Lamp Blinking (One blink)

<b>Applicable Models</b>	ON/OFF controller Centralized controller Schedule timer
<b>Error Code</b>	—
<b>Method of Error Detection</b>	DIII-NET communication data is used to detect the error.
<b>Error Decision Conditions</b>	<ul style="list-style-type: none"> <li>■ The previously connected centralized controller is not responding.</li> <li>■ Control range duplication</li> <li>■ There are multiple main centralized controllers.</li> <li>■ There are other centralized controllers but the schedule timer is set for individual use.</li> <li>■ There is a remote control adapter.</li> </ul>
<b>Supposed Causes</b>	<ul style="list-style-type: none"> <li>■ Centralized controller address duplication</li> <li>■ Poor centralized controller combination</li> <li>■ Multiple main centralized controllers</li> <li>■ Transmission defect between centralized controllers</li> <li>■ Defective centralized controller PCB</li> </ul>



Troubleshooting

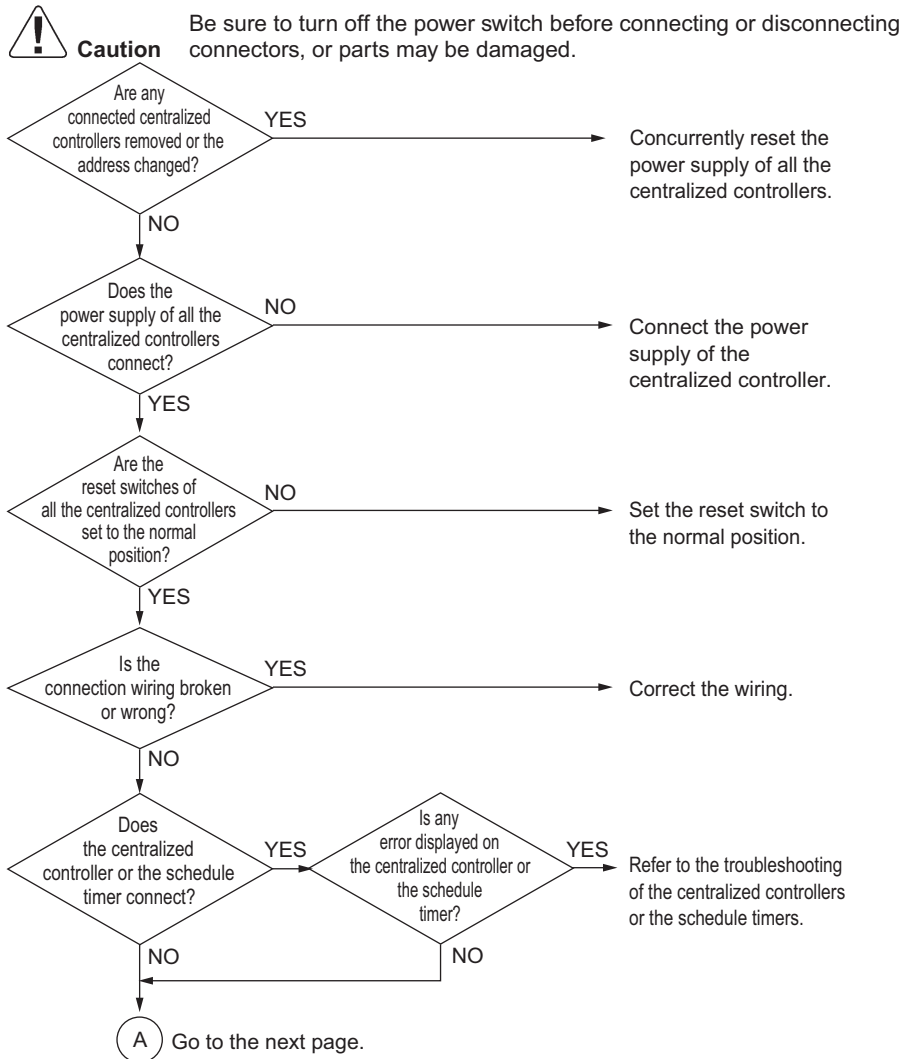

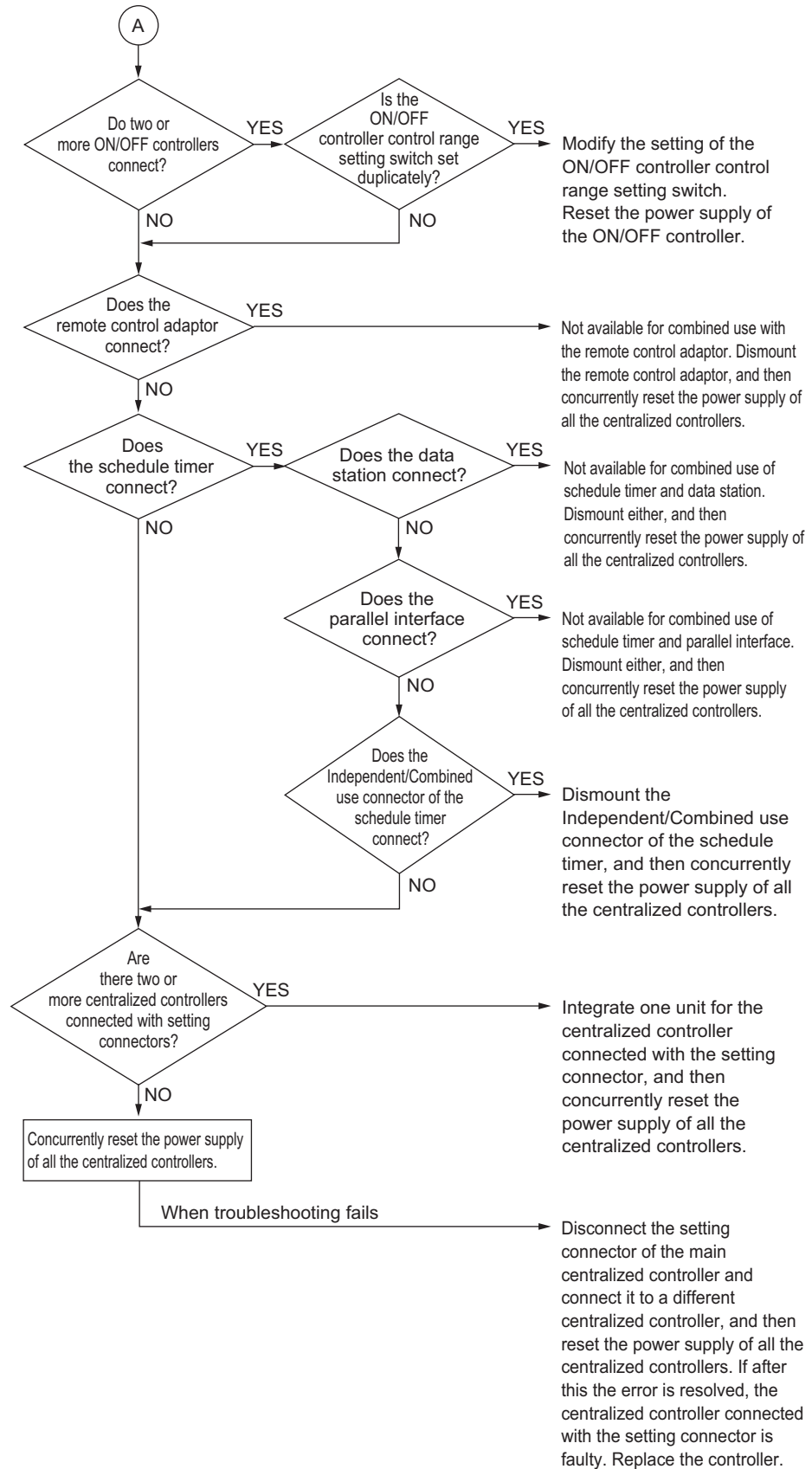

## 5.70 Central Control Indicator Lamp Blinking (Two blinks)

**Applicable Models** ON/OFF controller

**Error Code** —

**Method of Error Detection** DIII-NET communication data is used to detect the error.

**Error Decision Conditions** The indoor unit has no centralized control address set  
No indoor unit within the control range

**Supposed Causes**

- The indoor unit has no centralized control address set (Group No.)
- Control range setting switch set incorrectly
- Wiring connection error

### Troubleshooting



**Caution**

Be sure to turn off the power switch before connecting or disconnecting connectors, or parts may be damaged.

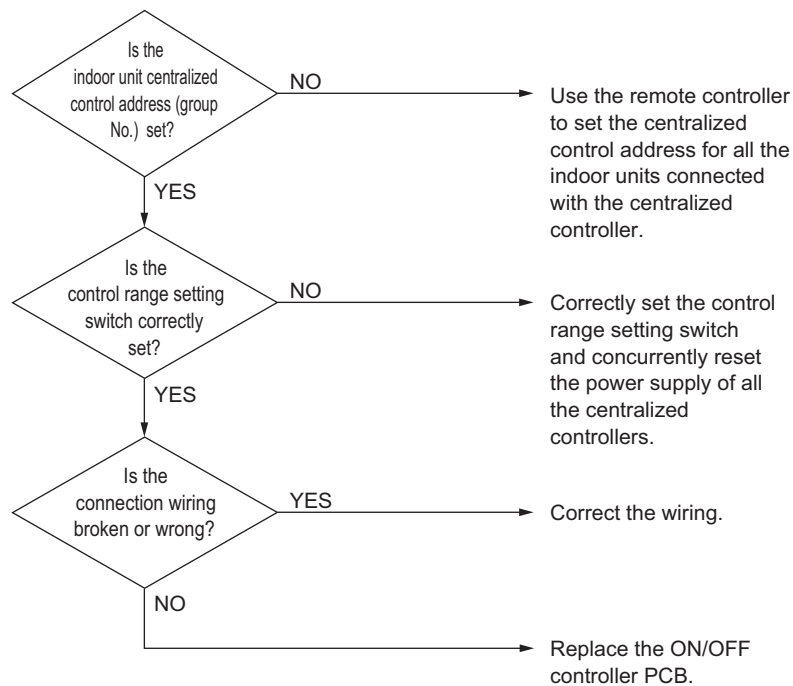

# 6. Check

## 6.1 High Pressure Check

### CHECK 1

Referring to the Fault Tree Analysis (FTA) shown below, probe the defective points.

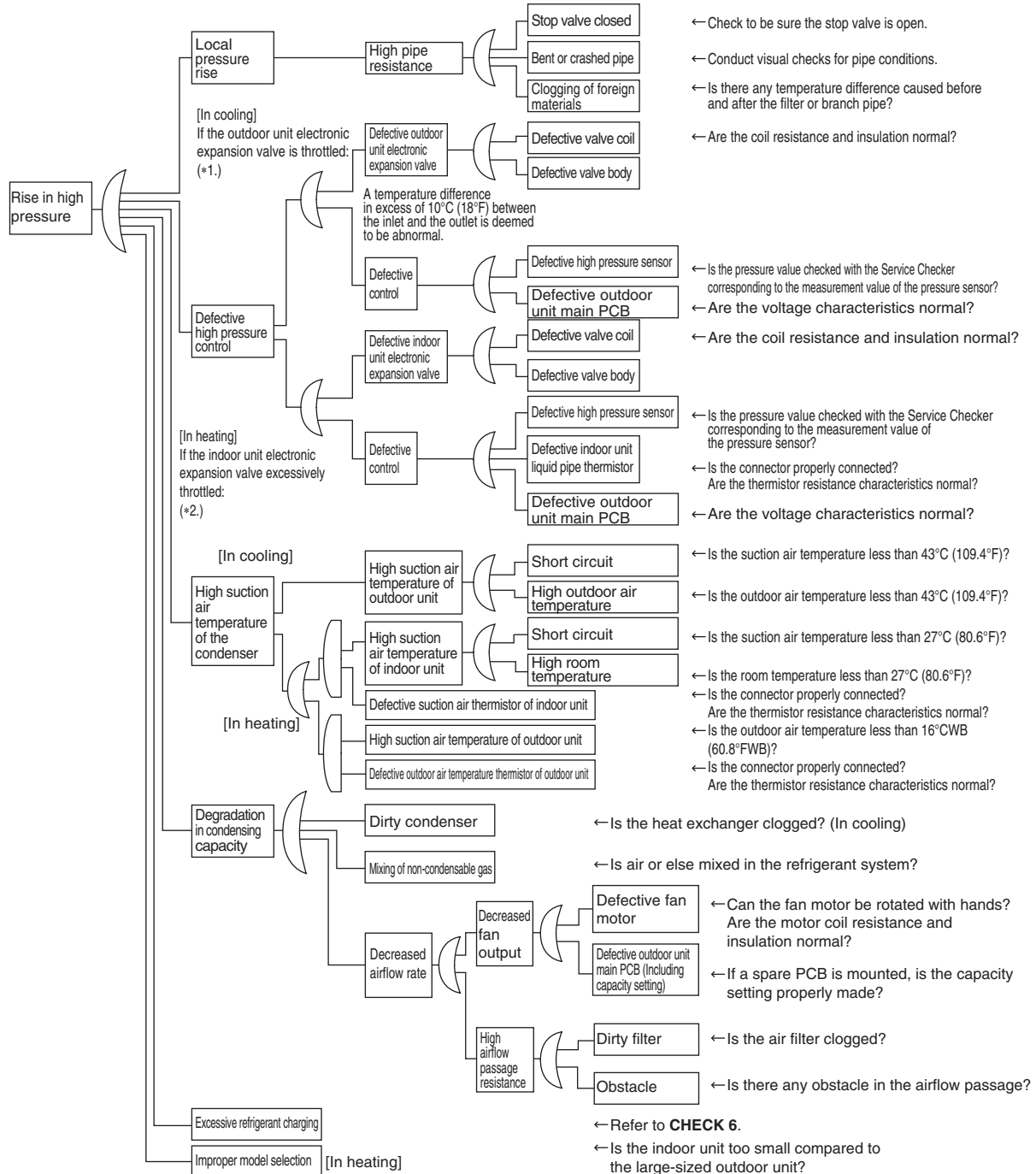

**i** Note(s)

- \*1. In cooling, it is normal if the outdoor unit electronic expansion valve (main) is fully open.
- \*2. In heating, the indoor unit electronic expansion valve is used for subcooling degree control.

**Reference**

**CHECK 6** Refer to page 315.

## 6.2 Low Pressure Check

### CHECK 2

Referring to the Fault Tree Analysis (FTA) shown below, probe the defective points

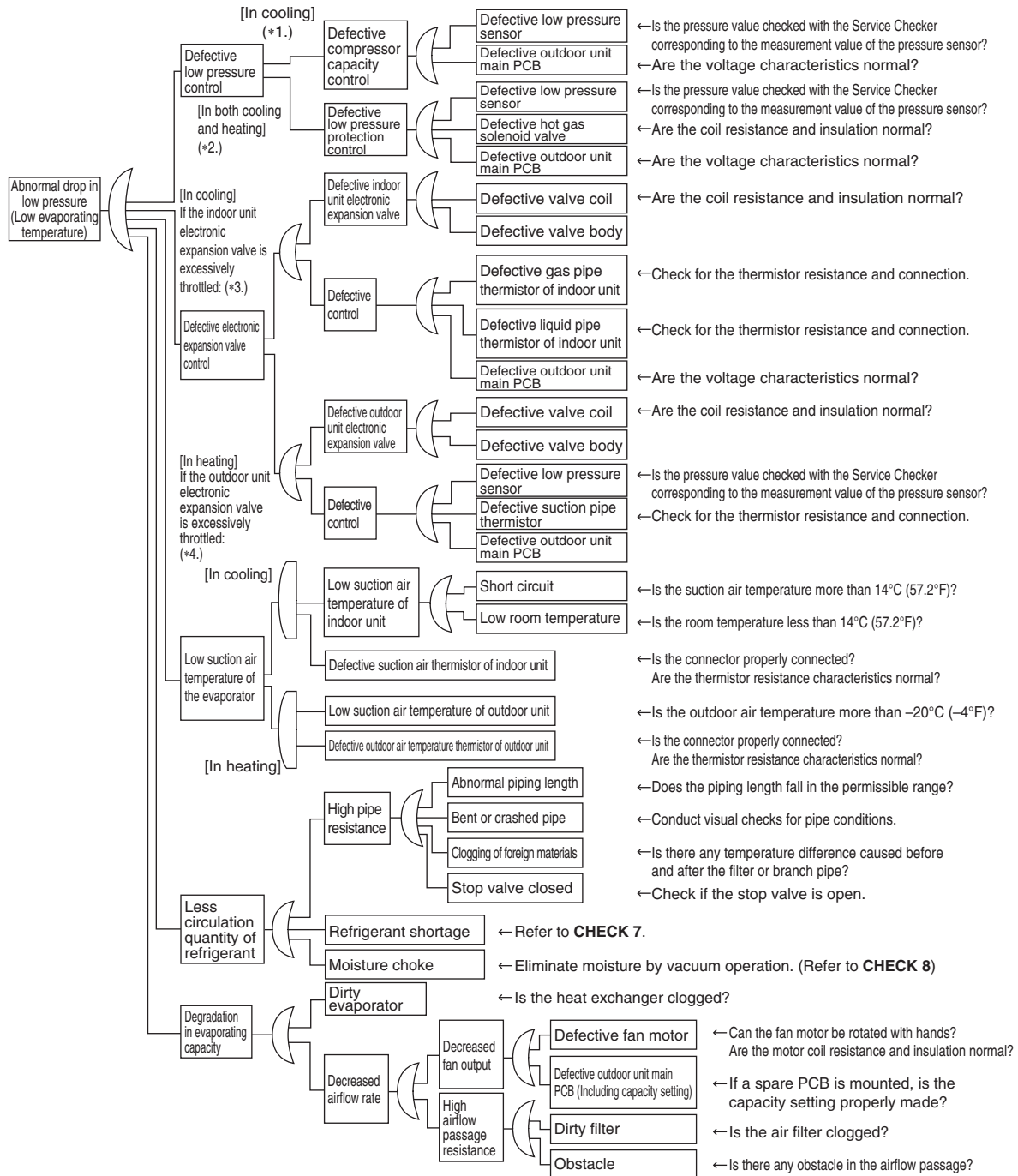

**i** Note(s)

- \*1. For details of compressor capacity control while in cooling, refer to Compressor PI control.
- \*2. The low pressure protection control includes low pressure protection control and hot gas bypass control.
- \*3. In cooling, the indoor unit electronic expansion valve is used for superheating degree control.
- \*4. In heating, the outdoor unit electronic expansion valve (main) is used for superheating degree control of outdoor heat exchanger.



**Reference**    **CHECK 7** Refer to page 316.



**Reference**    **CHECK 8** Refer to page 317.

# 6.3 Superheat Operation Check

## CHECK 3

Referring to the Fault Tree Analysis (FTA) shown below, probe the defective points.

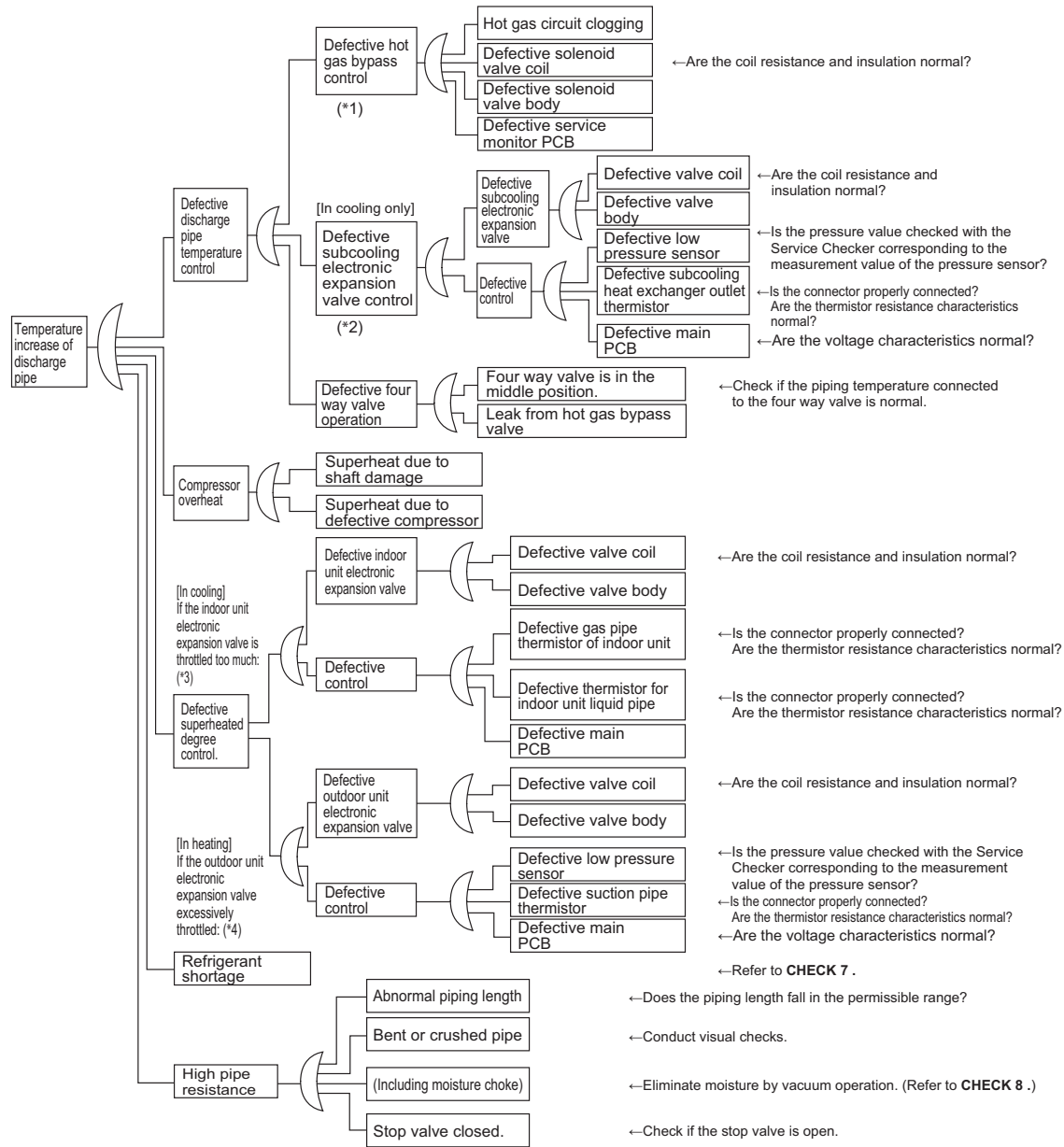

**i** Note(s)

- \*1: Refer to Low pressure protection control on page 92.
- \*2: Refer to Subcooling electronic expansion valve control on page 83.
- \*3: Superheating temperature control in cooling is conducted by indoor unit electronic expansion valve.
- \*4: Superheating temperature control in heating is conducted by outdoor unit electronic expansion valve.
- \*5: Judgment criteria of superheat operation: (1) Suction gas superheated degree: 10°C (18°F) and over. (2) Discharge gas superheated degree: 45°C (81°F) and over, except immediately after compressor starts up or is running under dropping control. (Use the above values as a guide. Depending on the other conditions, the unit may be normal despite the values within the above range.)



**Reference**    **CHECK 7** Refer to page 316.



**Reference**    **CHECK 8** Refer to page 317.



## 6.4 Power Transistor Check

### CHECK 4

Perform the following procedures prior to check.

- (1) Power OFF.
- (2) Remove all the wiring connected to the PCB where power transistors are mounted on.

[Preparation]

· Multimeter

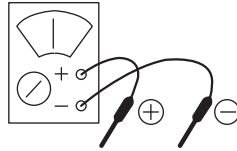

\* Preparing a multimeter in the analog system is recommended.

A multimeter in the digital system with diode check function will be usable.

[Point of Measurement and Judgment Criteria]

· Measure the resistance value using a tester at each point of measurement below, 10 minutes later after power OFF.

To use analog multimeter:

Measurement in the resistance value mode in the range of multiplying 1 k $\Omega$ .

No.	Point of Measurement		Judgment Criteria	Remarks
	+	-		
1	P2	U	2 ~ 15 k $\Omega$	—
2	P2	V		
3	P2	W		
4	U	P2	15 k $\Omega$ and above (including $\infty$ )	Due to condenser charge and so on, resistance measurement may require some time.
5	V	P2		
6	W	P2		
7	N3	U		
8	N3	V		
9	N3	W	2 ~ 15 k $\Omega$	—
10	U	N3		
11	V	N3		
12	W	N3		

To use digital multimeter:

Measurement is executed in the diode check mode.(→|←)

No.	Point of Measurement		Judgment Criteria	Remarks
	+	-		
1	P2	U	1.2 V and over	Due to condenser charge and so on, resistance measurement may require some time.
2	P2	V		
3	P2	W		
4	U	P2	0.3 ~ 0.7 V	—
5	V	P2		
6	W	P2		
7	N3	U		
8	N3	V		
9	N3	W	1.2 V and over	Due to condenser charge and so on, resistance measurement may require some time.
10	U	N3		
11	V	N3		
12	W	N3		

## 6.5 Refrigerant Overcharge Check

### CHECK 6

In case of **VRV** Systems, the only way to judge as the overcharge of refrigerant is with operating conditions due to the relationship to pressure control and electronic expansion valve control. As information for making a judgment, refer to the information below.

#### Diagnosis of refrigerant overcharge

1. High pressure rises. Consequently, overload control is conducted to cause insufficient cooling capacity.
2. The superheating degree of suction gas lowers (or wet operation is performed). Consequently, the compressor becomes lower in discharge pipe temperature despite of pressure loads.
3. The subcooling degree of condensate rises. Consequently, in heating, the temperature of discharge air through the subcooled section becomes lower.

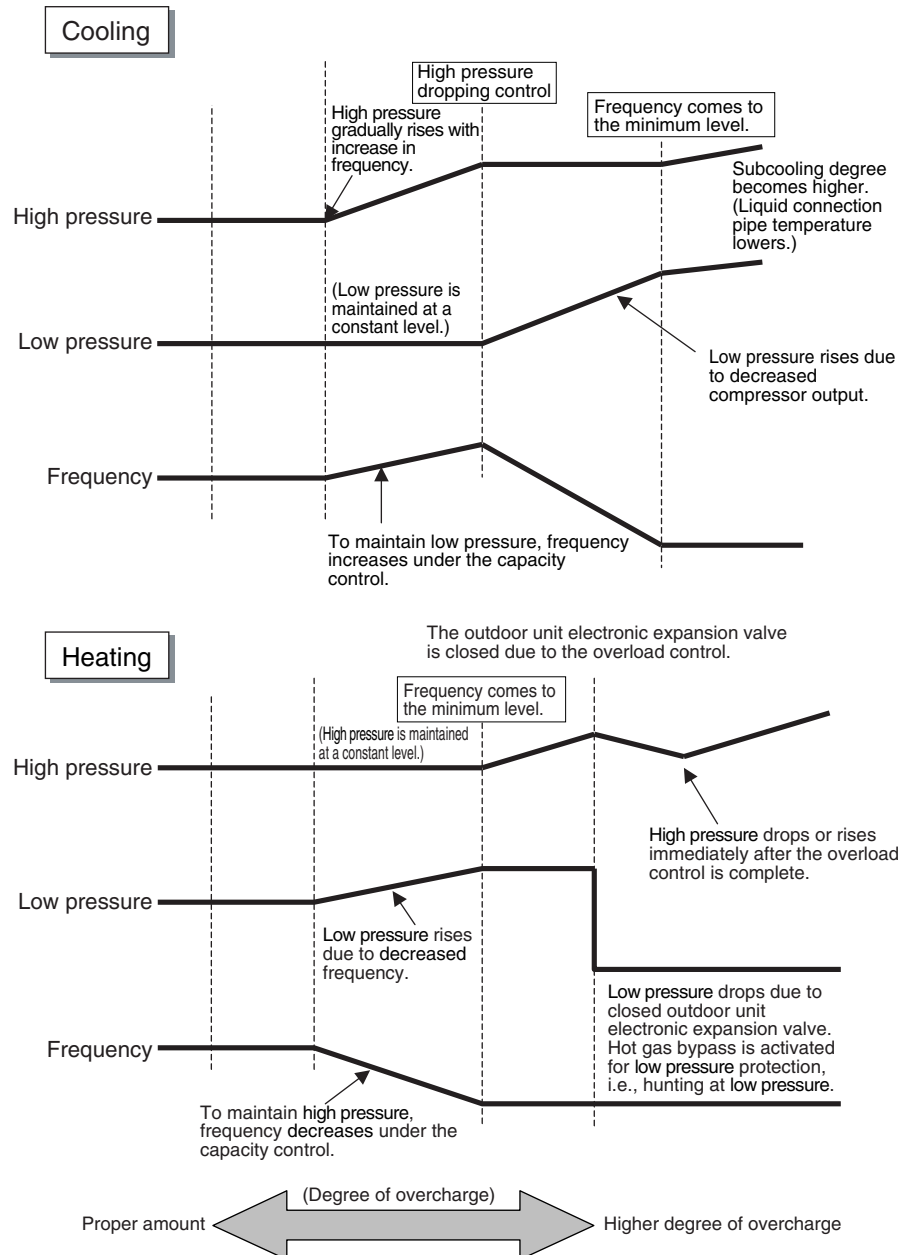

## 6.6 Refrigerant Shortage Check

### CHECK 7

In case of **VRV** Systems, the only way to judge as the shortage of refrigerant is with operating conditions due to the relationship to pressure control and electronic expansion valve control. As information for making a judgement, refer to the information below.

#### Diagnosis of shortage of refrigerant

1. The superheating degree of suction gas rises. Consequently, the compressor discharge gas temperature becomes higher.
2. The superheating degree of suction gas rises. Consequently, the electronic expansion valve turns open.
3. Low pressure drops to cause the unit not to demonstrate cooling/heating capacity.

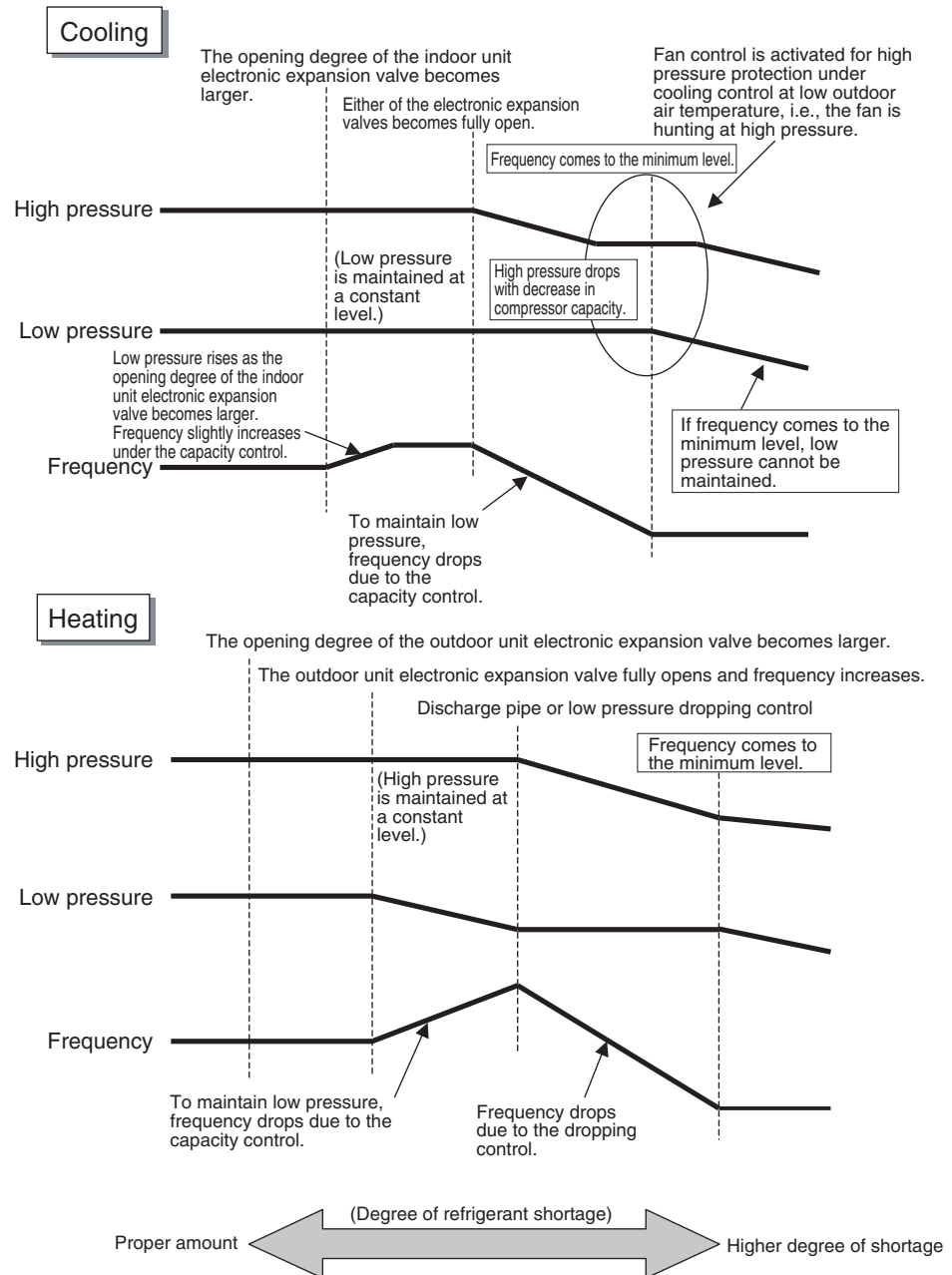

## 6.7 Vacuuming and Dehydration Procedure

---

### CHECK 8

Conduct vacuuming and dehydration in the piping system following the procedure for Normal vacuuming and dehydration described below.

Furthermore, if moisture may get mixed in the piping system, follow the procedure for Special vacuuming and dehydration described below.

#### Normal vacuuming and dehydration

1. Vacuuming and dehydration
  - Use a vacuum pump that enables vacuuming up to 500 microns.
  - Connect manifold gauges to the service ports of liquid pipe and gas pipe and run the vacuum pump for a period of 2 or more hours to conduct evacuation to 500 microns.
  - If the degree of vacuum does not reach 500 microns or less even though evacuation is conducted for a period of 2 hours, moisture will have entered the system or refrigerant leakage will have been caused. In this case, conduct evacuation for a period of another 1 hour.
  - If the degree of vacuum does not reach 500 microns or less even though evacuation is conducted for a period of 3 hours, conduct the leak tests.
2. Leaving in vacuum state
  - Leave the compressor at the degree of vacuum of 500 microns or less for a period of 1 hour or more, and then check to be sure that the vacuum gauge reading does not rise. (If the reading rises, moisture may have remained in the system or refrigerant leakage may have been caused.)
3. Additional refrigerant charge
  - Purge air from the manifold gauge connection hoses, and then charge a necessary amount of refrigerant.

#### Special vacuuming and dehydration

Use this procedure if moisture may get into the piping, such as construction during the rainy season (dew condensation may occur, or rainwater may enter the piping during construction work).

1. Vacuuming and dehydration
  - Follow the same procedure as that for normal vacuuming and dehydration described above.
2. Vacuum break
  - Pressurize with nitrogen gas up to 375,000 microns.
3. Vacuuming and dehydration
  - Conduct vacuuming and dehydration for a period of 1 hour or more. If the degree of vacuum does not reach 500 microns or less even though evacuation is conducted for a period of 2 hours or more, repeat vacuum break - vacuuming and dehydration.
4. Leaving in vacuum state
  - Leave the compressor at the degree of vacuum of 500 microns or less for a period of 1 hour or more, and then check to be sure that the vacuum gauge reading does not rise.
5. Additional refrigerant charge
  - Purge air from the manifold gauge connection hoses, and then charge a necessary amount of refrigerant.

## 6.8 List of Inverter-Related Error Codes

### CHECK 9

	Code	Name	Condition for determining error	Major cause
Compressor current	L5	Instantaneous overcurrent of compressor	<ul style="list-style-type: none"> <li>Inverter output current exceeds 59.1 A even instantaneously.</li> </ul>	<ul style="list-style-type: none"> <li>Liquid sealing</li> <li>Defective compressor</li> <li>Defective inverter PCB</li> </ul>
	L8	Overcurrent of compressor (Electronic superheating protection sensor)	<ul style="list-style-type: none"> <li>Compressor overload running</li> <li>A current of 33.5 A or more continues for a period of consecutive 5 seconds or that of 27.6 A or more continues for a period of consecutive 260 seconds.</li> <li>The inverter loses synchronization.</li> </ul>	<ul style="list-style-type: none"> <li>Back-flow of compressor liquid</li> <li>Sudden changes in loads</li> <li>Disconnected compressor wiring</li> <li>Defective PCB</li> </ul>
Protection device and others	E5	Compressor lock	<ul style="list-style-type: none"> <li>The compressor is in the locked status (does not rotate).</li> </ul>	<ul style="list-style-type: none"> <li>Defective compressor</li> </ul>
	L1	Defective inverter PCB	<ul style="list-style-type: none"> <li>No output is given.</li> </ul>	<ul style="list-style-type: none"> <li>Defective heavy current part of compressor</li> </ul>
	L4	Radiation fin temperature rise	<ul style="list-style-type: none"> <li>The radiation fin temperature reaches 87°C (188°F) or more (while in operation).</li> </ul>	<ul style="list-style-type: none"> <li>Defective fan</li> <li>Running in overload for an extended period of time</li> <li>Defective PCB</li> </ul>
	L9	Defective startup of inverter compressor	<ul style="list-style-type: none"> <li>The compressor motor fails to start up.</li> </ul>	<ul style="list-style-type: none"> <li>Liquid sealing or defective compressor</li> <li>Excessive oil or refrigerant</li> <li>Defective PCB</li> </ul>
	LC	Transmission error between microcomputers on the outdoor unit main PCB	<ul style="list-style-type: none"> <li>No communications are carried out across the microcomputers on the outdoor unit main PCB.</li> </ul>	<ul style="list-style-type: none"> <li>Defective outdoor unit main PCB</li> </ul>
	P1	Imbalanced power supply	<ul style="list-style-type: none"> <li>Power supply voltages get significantly imbalanced among three phases.</li> </ul>	<ul style="list-style-type: none"> <li>Power supply error (imbalanced voltages of 2% or more)</li> <li>Defective PCB</li> <li>Dead PCB</li> </ul>
	P4	Defective radiation fin thermistor	<ul style="list-style-type: none"> <li>The radiation fin thermistor gets short circuited or open.</li> </ul>	<ul style="list-style-type: none"> <li>Defective radiation fin thermistor</li> </ul>
	U2	Power supply voltage error	<ul style="list-style-type: none"> <li>The inverter power supply voltage is high or low.</li> </ul>	<ul style="list-style-type: none"> <li>Power supply error</li> <li>Defective PCB</li> </ul>

## 6.9 Concept of Inverter-Related Error Codes

### CHECK 10

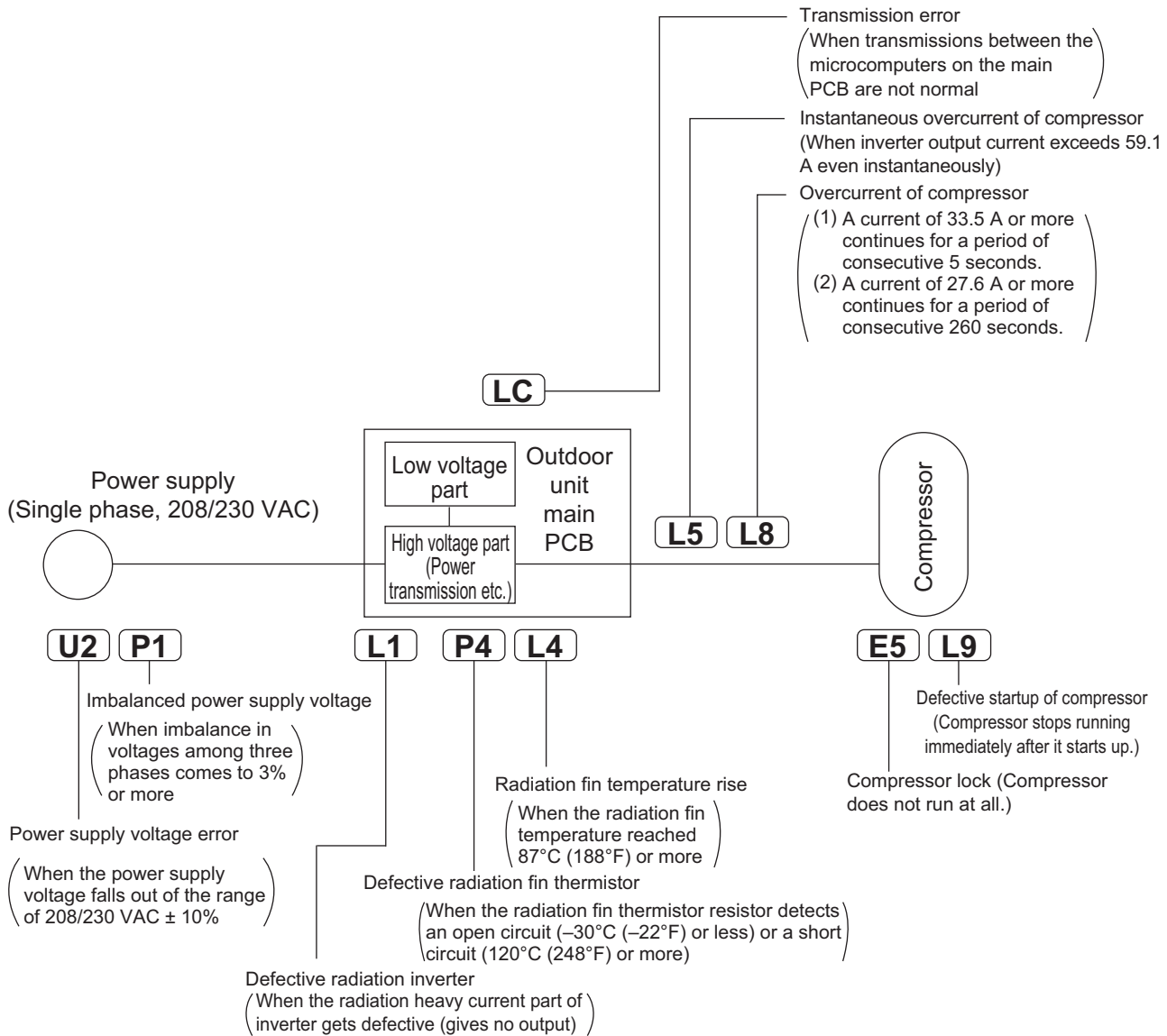

## 6.10 Thermistor Check

### CHECK 11 Thermistor type of indoor units

Model	Suction air thermistor	Indoor heat exchanger (liquid) thermistor	Indoor heat exchanger (gas) thermistor	Discharge air thermistor
	R1T	R2T	R3T	R4T
FXFQ-T	Type C	Type A	Type J	—
FXFQ-P	Type D		Type J	—
FXZQ-TA	Type B		Type A	—
FXZQ-TB			Type J	—
FXZQ-M			Type A	—
FXUQ-P	Type C		Type J	—
FXUQ-PA			Type A	—
FXEQ-P	Type B		Type J	—
FXDQ-M			Type A	—
FXSQ-TA			Type J	—
FXSQ-TB			Type A	—
FXMQ-PB			Type J	Type J
FXMQ-TB			Type A	—
FXHQ-M			Type J	—
FXAQ-P			Type A	—
FXLQ-M			Type J	—
FXNQ-M			Type J	—
FXTQ-TA	—		Type A	—
CXTQ-TA	—		Type A	—
FXMQ-MF	Type B		Type J	Type J

### Thermistor type of outdoor units

Electric symbol	Thermistor	Type		
		24/36 class	48 class	60 class
R1T	Outdoor air	E	E	E
R2T	Discharge pipe	G	G	G
R3T	Suction pipe 1	A	A	A
R4T	Heat exchanger deicer	A	A	A
R5T	Suction pipe 2	A	A	A
R6T	Subcooling heat exchanger gas pipe	—	—	A
R7T	Liquid pipe	A	A	A
R10T/FINTH	Radiation fin	K	K	K

Thermistor temperature		Resistance (k $\Omega$ )				
(°C)	(°F)	Type A	Type B	Type C	Type D	Type E
-30	-22	363.8	—	—	336.7	357.9
-25	-13	266.8	—	—	253.1	263.5
-20	-4	197.8	—	—	191.2	196.1
-15	5	148.2	—	—	144.1	147.4
-10	14	112.0	111.1	111.8	109.6	111.8
-5	23	85.52	84.95	85.42	84.05	85.53
0	32	65.84	65.53	65.80	64.99	66.00
5	41	51.05	50.95	51.07	50.64	51.31
10	50	39.91	39.92	39.97	39.74	40.20
15	59	31.44	31.50	31.51	31.41	31.74
20	68	24.95	25.02	25.02	24.98	25.23
25	77	19.94	20.00	20.00	20.00	20.19
30	86	16.04	16.10	16.10	16.12	16.26
35	95	12.99	13.04	13.04	13.07	13.17
40	104	10.58	10.63	10.63	10.67	10.74
45	113	8.669	8.720	8.711	8.757	8.806
50	122	7.143	7.189	7.179	7.227	7.260
55	131	5.918	—	—	5.997	6.014
60	140	4.928	—	—	5.001	5.008
65	149	4.123	—	—	4.191	4.191
70	158	3.467	—	—	3.528	3.525
75	167	—	—	—	2.984	2.978
80	176	—	—	—	2.534	2.527
85	185	—	—	—	2.161	2.153
90	194	—	—	—	1.850	1.843
95	203	—	—	—	1.590	1.583
100	212	1.339	—	—	1.371	1.365
105	221	—	—	—	1.188	1.181
Drawing No.		3SA48002 3SA48004 3SA48018 3SA48019 (AD94A045) 3SA48013 (AD100026)	3SA48001 (AD210486)	3SA48016 (AD100008)	4P159172 (AD010555)	3S480025 (AD180054)

\*The data is for reference purpose only.



Thermistor temperature		Resistance (k $\Omega$ )		
(°C)	(°F)	Type G	Type J	Type K
-30	-22	4759	352.1	350.6
-25	-13	3454	261.2	257.4
-20	-4	2534	195.4	191.0
-15	5	1877	147.3	143.2
-10	14	1404	111.8	108.4
-5	23	1059	85.49	82.83
0	32	806.5	65.80	63.80
5	41	618.9	51.15	49.53
10	50	478.8	40.08	38.75
15	59	373.1	31.64	30.56
20	68	292.9	25.16	24.26
25	77	231.4	20.14	19.40
30	86	184.1	16.23	15.62
35	95	147.4	13.16	12.65
40	104	118.7	10.73	10.31
45	113	96.13	8.800	8.447
50	122	78.29	7.255	6.962
55	131	64.10	6.012	5.769
60	140	52.76	5.010	4.805
65	149	43.63	4.196	4.021
70	158	36.26	3.532	3.381
75	167	30.27	2.987	2.856
80	176	25.38	2.538	2.422
85	185	21.37	2.166	2.063
90	194	18.06	1.857	1.764
95	203	15.33	1.598	1.515
100	212	13.06	1.380	1.305
105	221	11.17	1.196	1.128
110	230	9.585	1.041	0.9781
115	239	8.254	0.908	0.8506
120	248	7.131	0.795	0.7420
125	257	6.181	0.698	0.6495
130	266	5.374	0.615	0.5700
135	275	4.686	0.543	—
140	284	4.098	0.481	—
145	293	3.594	0.428	—
150	302	3.161	0.381	—
Drawing No.		3SA48009 (AD970175)	3SA48005 (AD190114)	3P204139 (AD070077)

\*The data is for reference purpose only.

# 6.11 Pressure Sensor Check

## CHECK 12

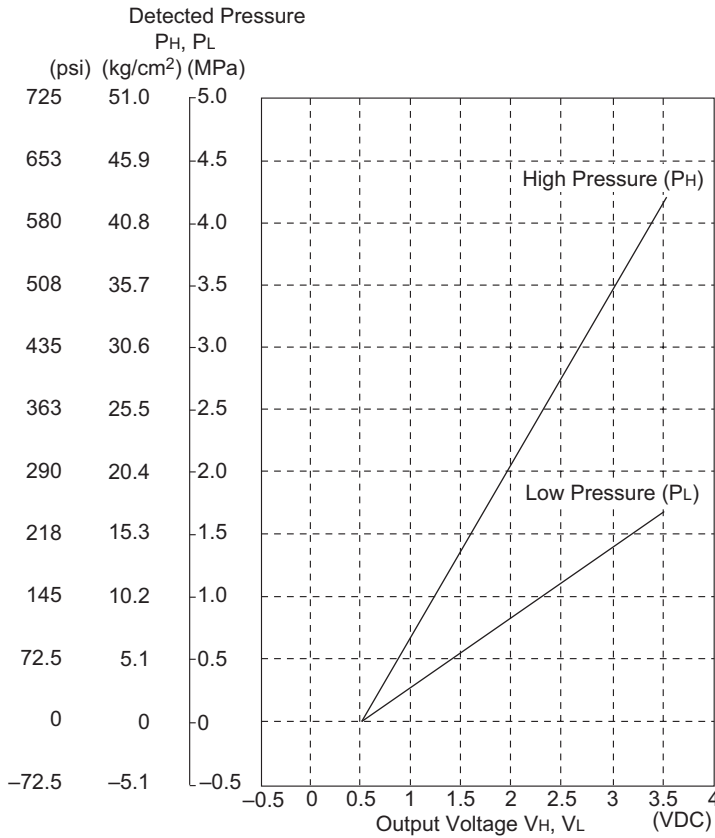

$$P_H \text{ (MPa)} = \frac{4.15}{3.0} \times V_H - \frac{4.15}{3.0} \times 0.5$$

$$P_L \text{ (MPa)} = \frac{1.7}{3.0} \times V_L - \frac{1.7}{3.0} \times 0.5$$

1 MPa = 145 psi

PH : High pressure (MPa)

PL : Low pressure (MPa)

VH : Output Voltage (High Side) (VDC)

VL : Output Voltage (Low Side) (VDC)

### Voltage Measurement Point of the High Pressure Sensor

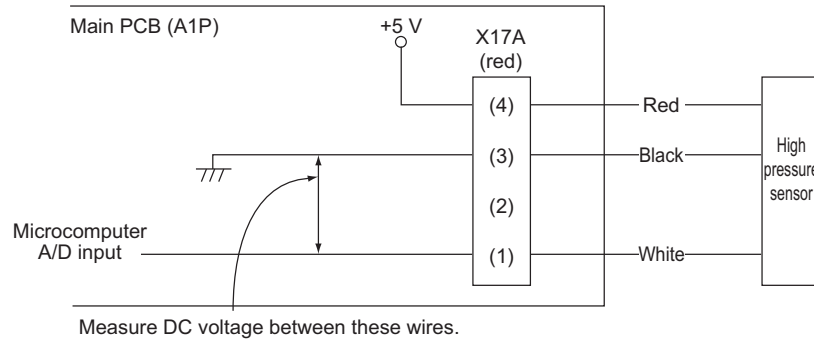

### Voltage Measurement Point of the Low Pressure Sensor

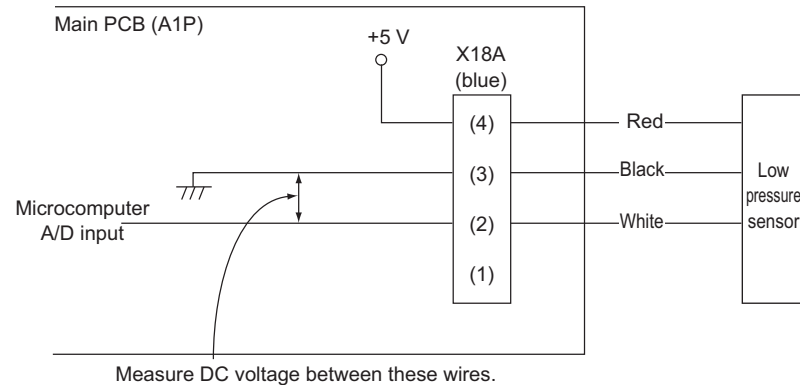

## 6.12 Master Unit Centralized Connector Setting Table

### CHECK 13

The master unit centralized setting connector (CN1/X1A) is mounted at the factory.

- ◆ To independently use a single unit of the intelligent Touch Controller or a single unit of the central remote controller, do not dismount the master unit centralized setting connector (i.e., use the connector with the factory setting unchanged).
- ◆ To independently use the schedule timer, insert an independent-use setting connector. No independent-use setting connector has been mounted at the factory. Insert the connector, which is attached to the casing of the master unit, in the PCB (CN1/X1A). (Independent-use connector: Master unit centralized setting connector)
- ◆ To use two or more centralized controller in combination, make settings according to the table shown below.

Pattern	Central controller connection pattern				Setting of master unit centralized setting connector (*2)			
	intelligent Touch Controller	Central remote controller	Unified ON/OFF controller	Schedule timer	intelligent Touch Controller	Central remote controller	Unified ON/OFF controller	Schedule timer
(1)	1 to 2 units	—	—	× (*1)	Only a single unit: "Provided", Others: "Not provided"	—	—	—
(2)	1 unit	1 unit	—	× (*1)	Provided	Not provided	—	—
(3)			1 to 8 units	× (*1)			—	—
(4)	1 to 2 units	—	1 to 8 units	× (*1)	Only a single unit: "Provided", Others: "Not provided"	—	All "Not provided"	—
(5)	—	1 to 4 units	—	—	—	Only a single unit: "Provided", Others: "Not provided"	—	—
(6)	—		1 to 16 units	1 unit	—		All "Not provided"	Not provided
(7)	—		—	—	—		—	—
(8)	—		—	1 unit	—		—	Not provided
(9)	—	—	1 to 16 units	—	—	—	Only a single unit: "Provided", Others: "Not provided"	—
(10)	—	—		1 unit	—		—	Not provided
(11)	—	—	—	1 unit	—	—	—	Provided



#### Note(s)

- \*1 The intelligent Touch Controller and the schedule timer are not available for combined use.
- \*2 The intelligent Touch Controller, central remote controller, and the unified ON/OFF controller have been set to "Provided with the master unit centralized setting connector" at the factory. The schedule timer has been set to "Not provided with the master unit centralized setting connector" at the factory, which is attached to the casing of the master unit.

## 6.13 Master-Slave Unit Setting Table

### CHECK 14

Combination of intelligent Touch Controller and Central Remote Controller



* Pattern	#1		#2		#3		#4	
	1-00~4-15	Master/Slave	5-00~8-15	Master/Slave	1-00~4-15	Master/Slave	5-00~8-15	Master/Slave
(1)	CRC	Master	CRC	Master	CRC	Slave	CRC	Slave
(2)	CRC	Master	—	—	CRC	Slave	—	—
(3)	intelligent Touch Controller	Master	—	—	intelligent Touch Controller	Slave	—	—
(4)	CRC	Master	—	—	intelligent Touch Controller	Slave	—	—
(5)	intelligent Touch Controller	Master	—	—	CRC	Slave	—	—
(6)	CRC	Master	—	—	—	—	—	—
(7)	intelligent Touch Controller	Master	—	—	—	—	—	—



**Note(s)**

CRC (Central remote controller): DCS302CA61  
 intelligent Touch Controller: DCS601C51

\* The patterns marked with \* have nothing to do with those described in the list of setting of master unit centralized setting connector.

## 6.14 Broken Wire Check of the Relay Wires

### CHECK 15

Procedure for checking indoor-outdoor unit transmission wiring for broken wires (for checking the indoor-outdoor unit transmission wiring of the outdoor unit for broken wires).

Turn OFF the power supply to all equipment, short circuit between the indoor-outdoor unit terminal F1 and F2 in the outdoor unit, and then conduct continuity checks between the transmission wirings F1 and F2 of the "Indoor Unit a" that is farthest from the outdoor unit using a multimeter. If there is continuity between the said transmission wirings, the indoor-outdoor unit transmission wiring has no broken wires in it.

If there is no continuity, the transmission wiring may have broken wires. With the indoor-outdoor unit terminal of the outdoor unit short circuited, identify the place with continuity in the transmission wiring of the "Indoor Unit b", transmission wiring of the "Indoor Unit c", and transmission wiring of the "Indoor Unit d" in the order described.

If the place with continuity can be identified, there may be broken wires in places before the said place with continuity.

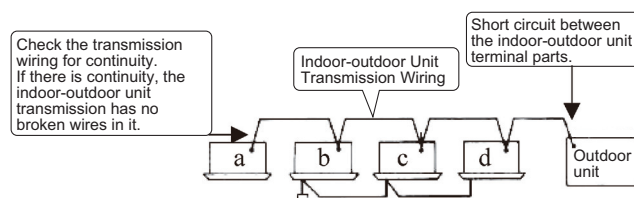

## 6.15 Fan Motor Connector Check (Power Supply Cable)

**CHECK 16**

Check the fan motor connector according to the following procedure.

**Indoor Unit**

**FXDQ-M, FXHQ-M**

1. Turn OFF the power supply.
2. Measure the resistance between phases of U, V, W at the motor side connectors (3-core wire) to check that the values are balanced and there is no short circuiting, while connector or relay connector is disconnected.

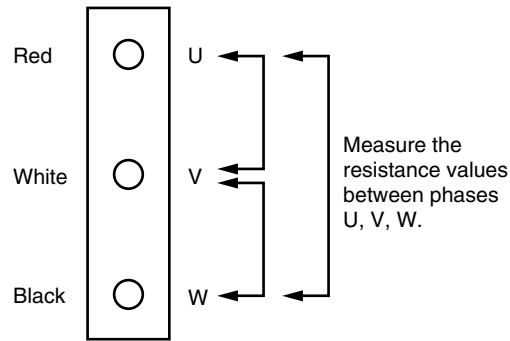

Model	Judgment	
	Black-Red	Black-White
FXDQ07-12M	71.0 Ω ± 10%	73.5 Ω ± 10%
FXDQ18/24M	39.2 Ω ± 10%	41.3 Ω ± 10%
FXHQ12M	71.0 Ω ± 10%	73.5 Ω ± 10%
FXHQ24/36M	53.5 Ω ± 10%	31.6 Ω ± 10%

**FXSQ54TA, FXSQ54TB, FXMQ15-54PB, FXMQ30-54TB**

Remove the X1A connector from the fan PCB (A2P) and measure the resistance between the U and V, V and W, and W and U phases of the motor connector (with five conductors) and check that each phase are balanced (within a permissible dispersion range of ±20%).

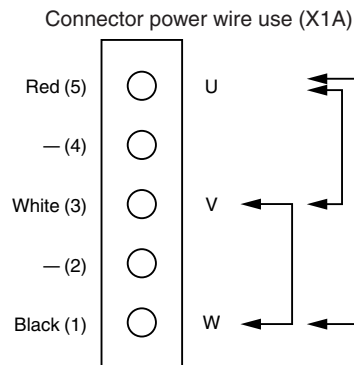

## 6.16 Fan Motor Connector Check (Signal Cable)

### CHECK 17

Resistance measuring points and judgment criteria.

**FXFQ-T, FXFQ09-30P, FXZQ-TA, FXZQ-TB, FXUQ-P, FXSQ05-48TA, FXSQ05-48TB, FXMQ07-12PB, FXMQ15-24TB, FXAQ-P, Outdoor unit**

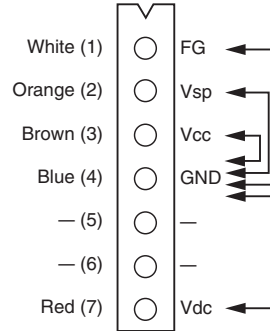

Judgment criteria

Measuring points	Criteria
1 - 4	1 Ω or more
2 - 4	1 Ω or more
3 - 4	1 Ω or more
7 - 4	1 Ω or more

### FXFQ36/48P

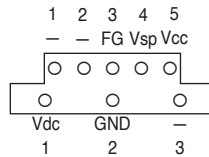

Judgment criteria

Measuring points	Criteria
3 - 2	1 Ω or more
4 - 2	1 Ω or more
5 - 2	1 Ω or more
1 - 2	1 Ω or more

**FXEQ-P, FXUQ-PA**

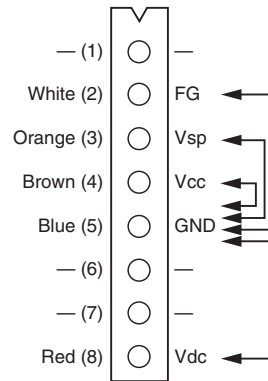

Judgment criteria

Measuring points	Criteria
2 - 5	1 Ω or more
3 - 5	1 Ω or more
4 - 5	1 Ω or more
8 - 5	1 Ω or more

**FXSQ54TA, FXSQ54TB, FXMQ15-54PB, FXMQ30-54TB**

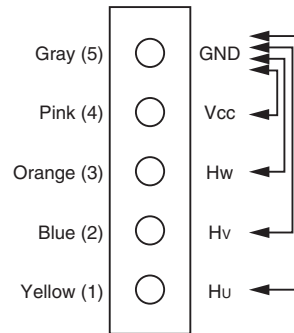

Judgment criteria

Measuring points	Criteria
5 - 4	1 Ω or more
5 - 3	1 Ω or more
5 - 2	1 Ω or more
5 - 1	1 Ω or more

# 6.17 Electronic Expansion Valve Coil Check

**CHECK 18**

Measure the connector pin-to-pin resistance and make sure that the resistance value is within the range listed in the table below.

**Outdoor Unit**

**24/36 class**



Measuring points	Judgment criteria
1 - 6	35-55 Ω
2 - 6	
3 - 6	
4 - 6	

**48/60 class**

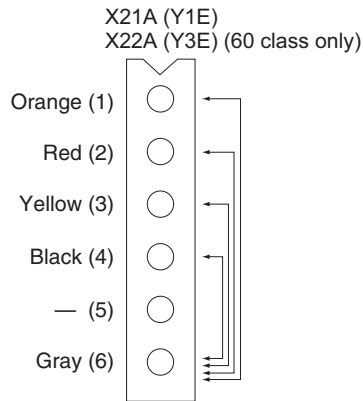

Measuring points	Judgment criteria
1 - 6	35-55 Ω
2 - 6	
3 - 6	
4 - 6	



Indoor Unit

**FXFQ-T, FXFQ-P, FXZQ-TA, FXZQ-TB, FXUQ-P, FXUQ-PA, FXEQ-P, FXSQ-TA, FXSQ-TB, FXMQ-TB, FXTQ-TA, CXTQ-TA**

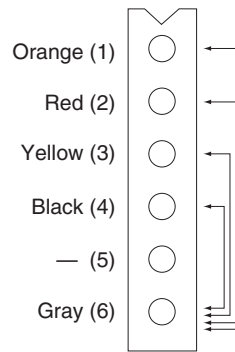

Measuring points	Judgment criteria
1 - 6	35-55 Ω
2 - 6	
3 - 6	
4 - 6	

**FXZQ-M, FXMQ-PB, FXAQ-P**



Measuring points	Judgment criteria
1 - 3	300 Ω
1 - 5	150 Ω
2 - 4	300 Ω
2 - 6	150 Ω

**FXDQ-M, FXHQ-M, FXLQ-M, FXNQ-M, FXMQ-MF**

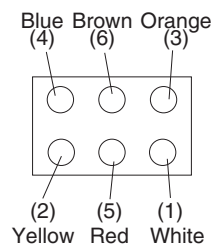

Measuring points	Judgment criteria
1 - 3	300 Ω
1 - 5	150 Ω
2 - 4	300 Ω
2 - 6	150 Ω

## 6.18 Fan Motor Connector Check for FXTQ-TA

### CHECK 19

#### CHECKING EMERSON ULTRATECH™ ECM MOTORS

The FXTQ-TA models utilize an Emerson, 4-wire variable speed ECM blower motor. The ECM blower motor provides constant CFM.

The motor is a serially communicating variable speed motor. Only four wires are required to control the motor: +Vdc, Common, Receive, and Transmit.

The +Vdc and Common wires provide power to the motor's low voltage control circuits.

#### General Checks / Considerations

1. Check power supply to the air handler or modular blower. Ensure power supply is within the range specified on rating plate.
2. Check motor power harness. Ensure wires are continuous and make good contact when seated in the connectors. Repair or replace as needed.
3. Check motor control harness. Ensure wires are continuous and make good contact when seated in the connectors. Repair or replace as needed.
4. Check blower wheel. Confirm wheel is properly seated on motor shaft. Set screw must be on shaft flat and torqued to 165 in-lbs minimum. Confirm wheel has no broken or loose blades. Repair or replace as needed.
5. Ensure motor and wheel turn freely. Check for interference between wheel and housing or wheel and motor. Repair or replace as needed.
6. Check housing for cracks and/or corrosion. Repair or replace as needed.
7. Check motor mounting bracket. Ensure mounting bracket is tightly secured to the housing. Ensure bracket is not cracked or broken.

#### Emerson UltraCheck-EZ™ Diagnostic Tool

The Emerson UltraCheck-EZ™ diagnostic tool may be used to diagnose the ECM motor.



#### Warning

HIGH VOLTAGE!

Disconnect ALL power before servicing or installing. Multiple power sources may be present. Failure to do so may cause property damage, personal injury or death.

To use the diagnostic tool, perform the following steps:

1. Disconnect power to the air handler.
2. Disconnect the 4-circuit control harness from the motor.
3. Plug the 4-circuit connector from the diagnostic tool into the motor control connector.
4. Connect one alligator clip from the diagnostic tool to a ground source.
5. Connect the other alligator clip to a 24VAC source.

**NOTE:** The alligator clips are NOT polarized.

**NOTE:** The Ultra Check-EZ™ diagnostic tool is equipped with a non-replaceable fuse. Connecting the tool to a source other than 24VAC could damage the tool and cause the fuse to open. Doing so will render the diagnostic tool inoperable.

6. Turn on power to air handler or modular blower.



#### Warning

Line Voltage now present.

7. Depress the orange power button on the diagnostic tool to send a run signal to the motor. Allow up to 5 seconds for the motor to start.

**NOTE:** If the orange power button does not illuminate when depressed, the tool either has an open fuse or is not properly connected to a 24VAC source.

8. The green LED on the diagnostic tool will blink indicating communications between the tool and motor. See table below for indications of tool indicators and motor actions. Replace or repair as needed.

Power Button	Green LED	Motor Action	Indication(s)
OFF	OFF	Not Rotating	Confirm 24VAC to UltraCheck-EZ™ tool. If 24VAC is confirmed, diagnostic tool is inoperable.
ON	Blinking	Rotating	Motor and control/end bell are functioning properly.
ON	OFF	Rotating	Replace motor control/end bell.
ON	Blinking	Not Rotating	Check motor (refer to Motor Checks on page 334).
ON	OFF	Not Rotating	Replace motor control/end bell; verify motor (refer to Motor Checks on page 334).

9. Depress the orange power button to turn off motor.
10. Disconnect power. Disconnect diagnostic tool.
11. Reconnect the 4-wire harness from control board to motor.

### Electrical Checks - High Voltage Power Circuits



#### Warning

#### HIGH VOLTAGE!

Disconnect ALL power before servicing or installing. Multiple power sources may be present. Failure to do so may cause property damage, personal injury or death.

1. Disconnect power to air handler or modular blower.
2. Disconnect the 5-circuit power connector to the ECM motor.
3. Turn on power to air handler or modular.



#### Warning

Line Voltage now present.

4. Measure voltage between pins 4 and 5 on the 5-circuit connector. Measured voltage should be the same as the supply voltage to the air handler or modular.

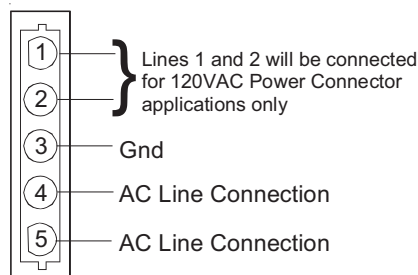

5. Measure voltage between pins 4 and 3. Voltage should be approximately half of the voltage measured in step 4.
6. Measure voltage between pins 5 and 3. Voltage should be approximately half of the voltage measured in step 4.
7. If no voltage is present, check supply voltage to air handler or modular blower.
8. Disconnect power to air handler or modular blower. Reconnect the 5-circuit power harness disconnected in step 2.

### Electrical Checks - Low Voltage Control Circuits

1. Turn on power to air handler or modular.



#### Warning

Line Voltage now present.

2. Check voltage between pins on the 4-wire motor control harness between the motor and control board.
3. Voltage on pins should read:
  - Pins 1 to 4 = 3.3vdc
  - Pins 1 to 2 = 3.3vdc
  - Pins 3 to 4 = 15vdc

### Motor Control/End Bell Checks



#### Warning

HIGH VOLTAGE!

Disconnect ALL power before servicing or installing. Multiple power sources may be present. Failure to do so may cause property damage, personal injury or death.

1. Disconnect power to air handler or modular blower.
  - NOTE:** Motor contains capacitors that can hold a charge for several minutes after disconnecting power. Wait 5 minutes after removing power to allow capacitors to discharge.
2. Disconnect the motor control harness and motor power harness.
3. Remove the blower assembly from the air handler or modular blower.
4. Remove the (3) screws securing the control/end bell to the motor. Separate the control/end bell. Disconnect the 3-circuit harness from the control/end bell to remove the control/end bell from the motor.
5. Inspect the NTC thermistor inside the control/end bell. Replace control/end bell if thermistor is cracked or broken.

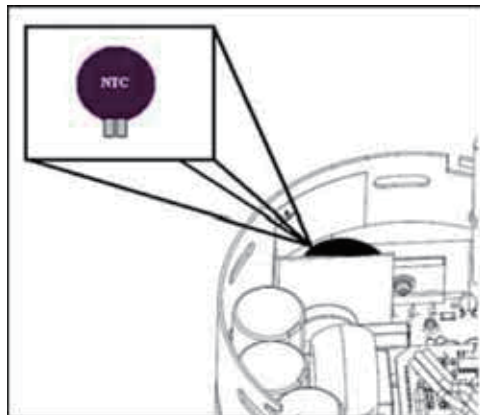

6. Inspect the large capacitors inside the control/end bell. Replace the control/end bell if any of the capacitors are bulging or swollen.

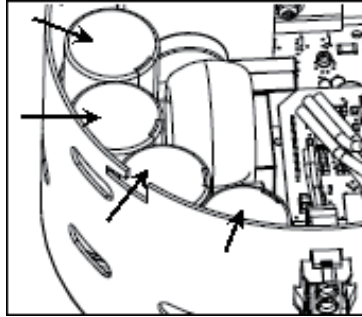

7. Locate the 3-circuit connector in the control/end bell. Using an ohmmeter, check the resistance between each terminal in the connector. If the resistance is 1 M $\Omega$  or greater, the control/end bell is functioning properly. Replace the control/end bell if the resistance is lower than 1 M $\Omega$ .
8. Reassemble motor and control/end bell in reverse of disassembly. Replace blower assembly into air handler or modular blower.

### Motor Checks



#### Warning

#### HIGH VOLTAGE!

Disconnect ALL power before servicing or installing. Multiple power sources may be present. Failure to do so may cause property damage, personal injury or death.

1. Disconnect power to air handler or modular blower.  
**NOTE:** Motor contains capacitors that can hold a charge for several minutes after disconnecting power. Wait 5 minutes after removing power to allow capacitors to discharge.
2. Disassemble motor as described in steps 2 through 4 above.
3. Locate the 3-circuit harness from the motor. Using an ohmmeter, measure the resistance between each motor phase winding. The resistance levels should be equal. Replace the motor if the resistance levels are unequal, open circuited or short circuited.
4. Measure the resistance between each motor phase winding and the motor shell. Replace the motor if any phase winding is short circuited to the motor shell.
5. Reassemble motor and control/end bell in reverse of disassembly. Replace blower assembly into air handler or modular blower.

---

# Part 7 Appendix

1. Wiring Diagrams.....	336
1.1 Outdoor Unit.....	336
1.2 Indoor Unit.....	342
1.3 Air Treatment Equipment .....	361

# 1. Wiring Diagrams

## 1.1 Outdoor Unit

RXSQ24/36TAVJU

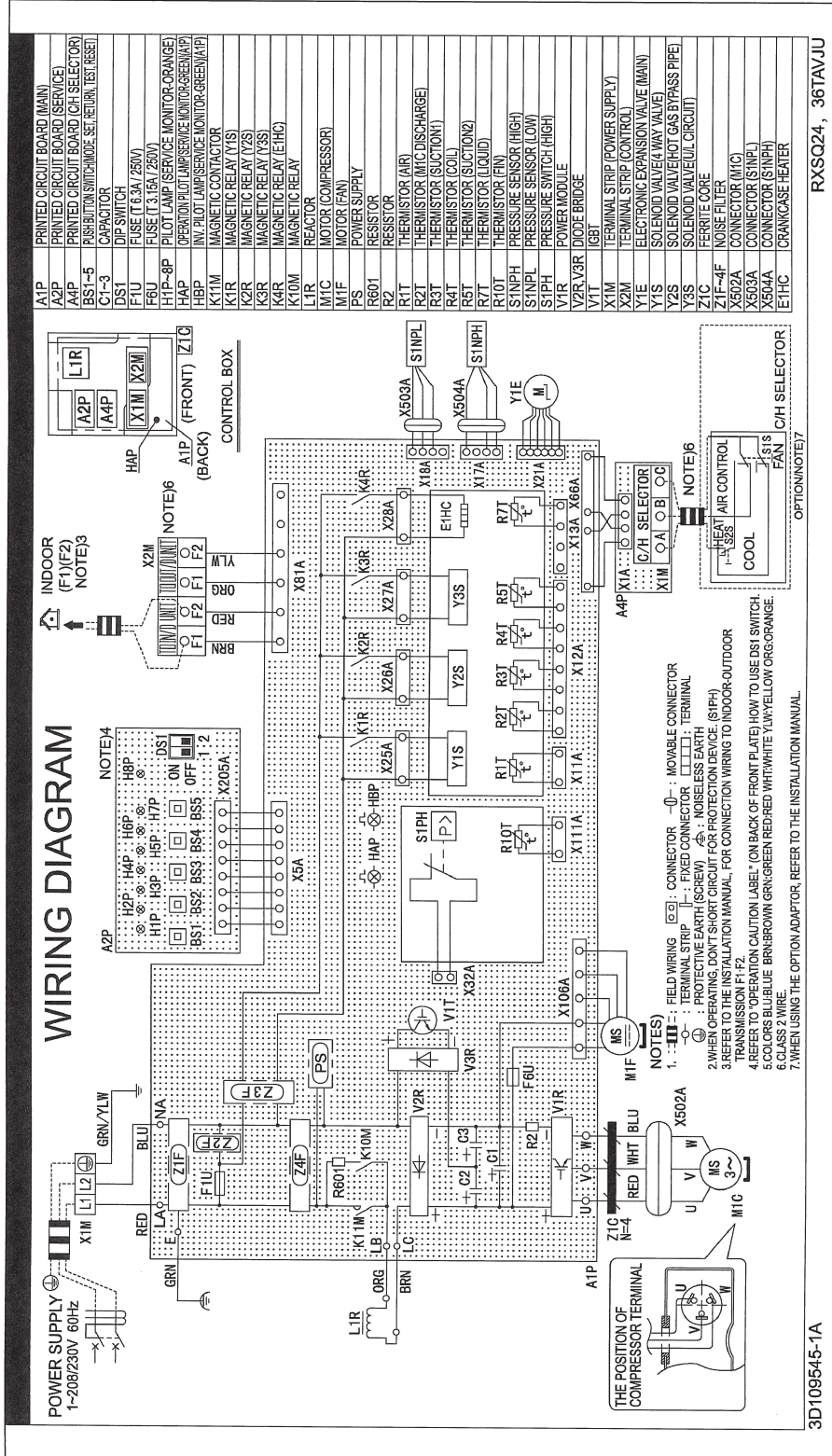

3D109545A

RXSQ24/36TAVJUA, RXSQ24/36TBVJUA

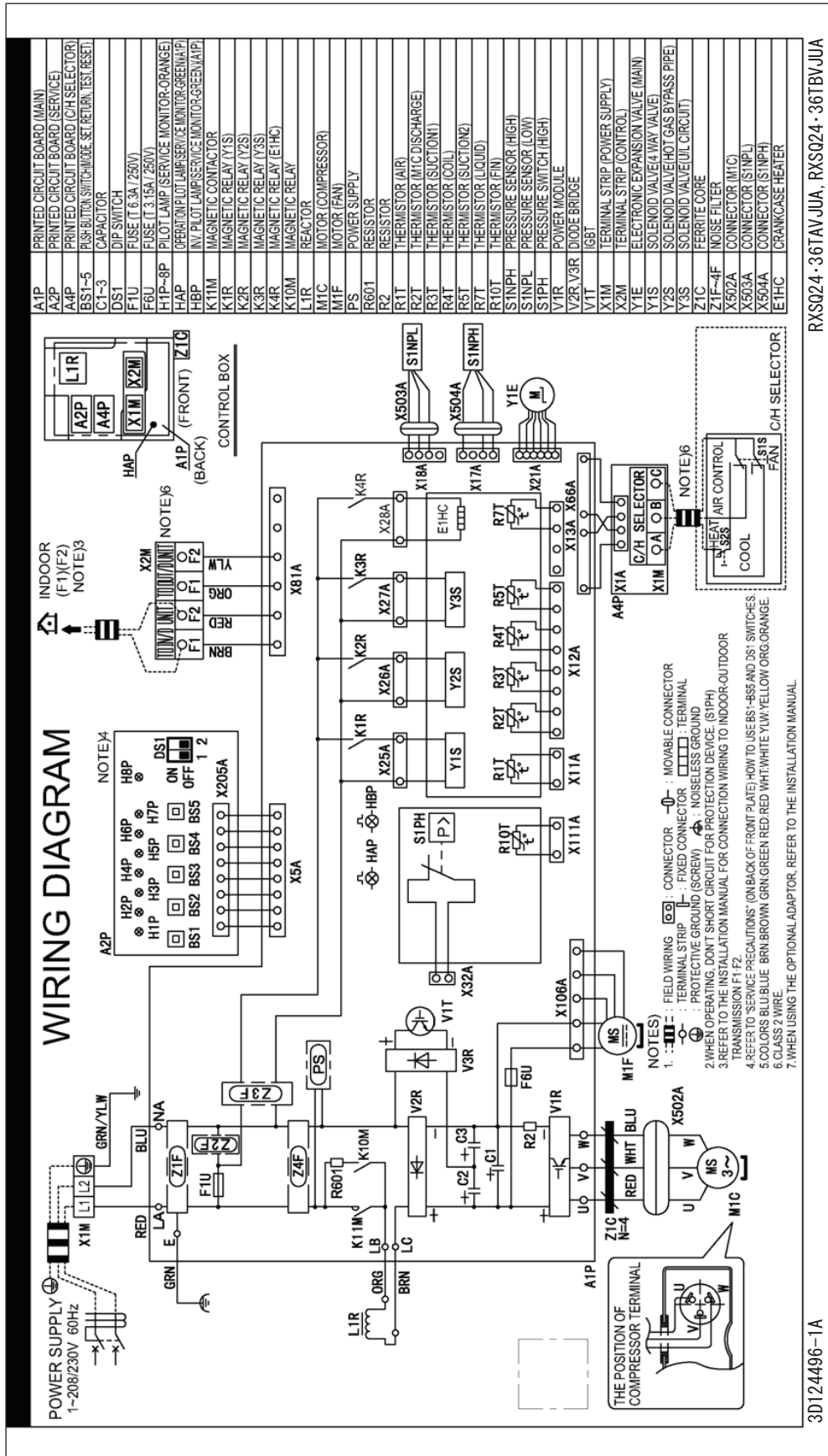

RXSQ24-36TAVJUA, RXSQ24-36TBVJUA

3D124496-1A

3D124496B



RXSQ48TAVJU

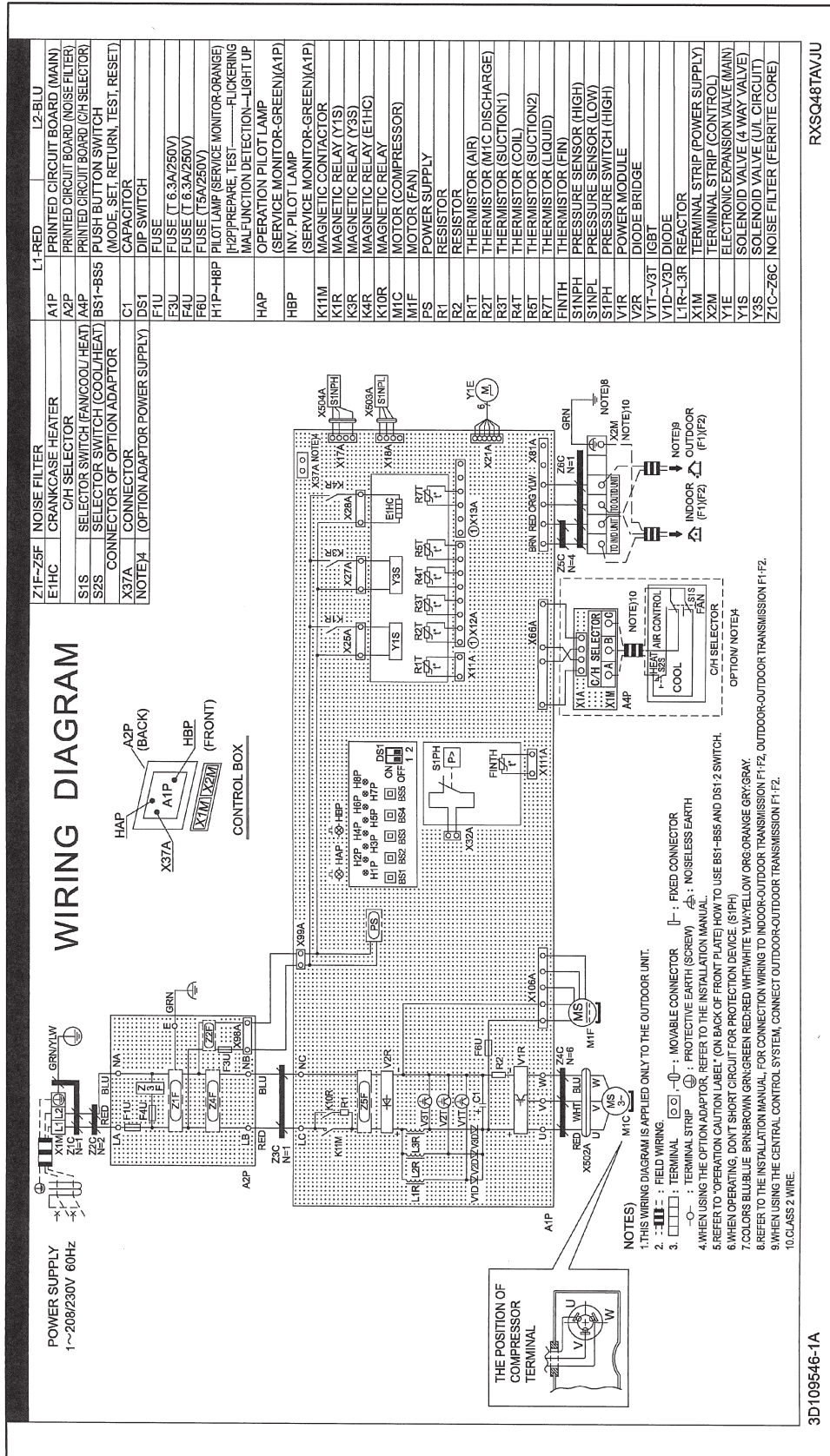

RXSQ48TAVJUA, RXSQ48TBVJUA

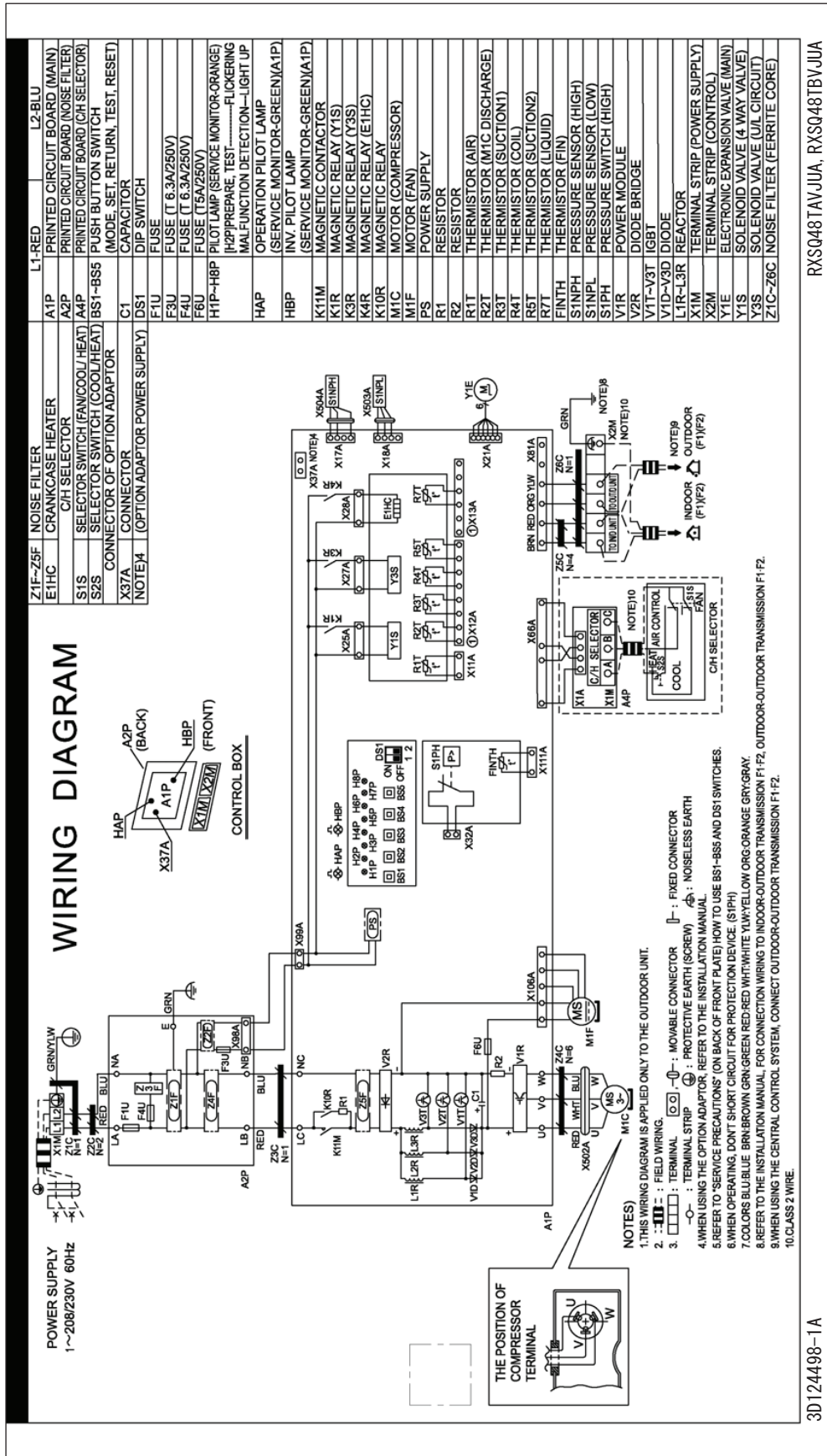

3D124498B

3D124498-1A

RXSQ60TAVJU

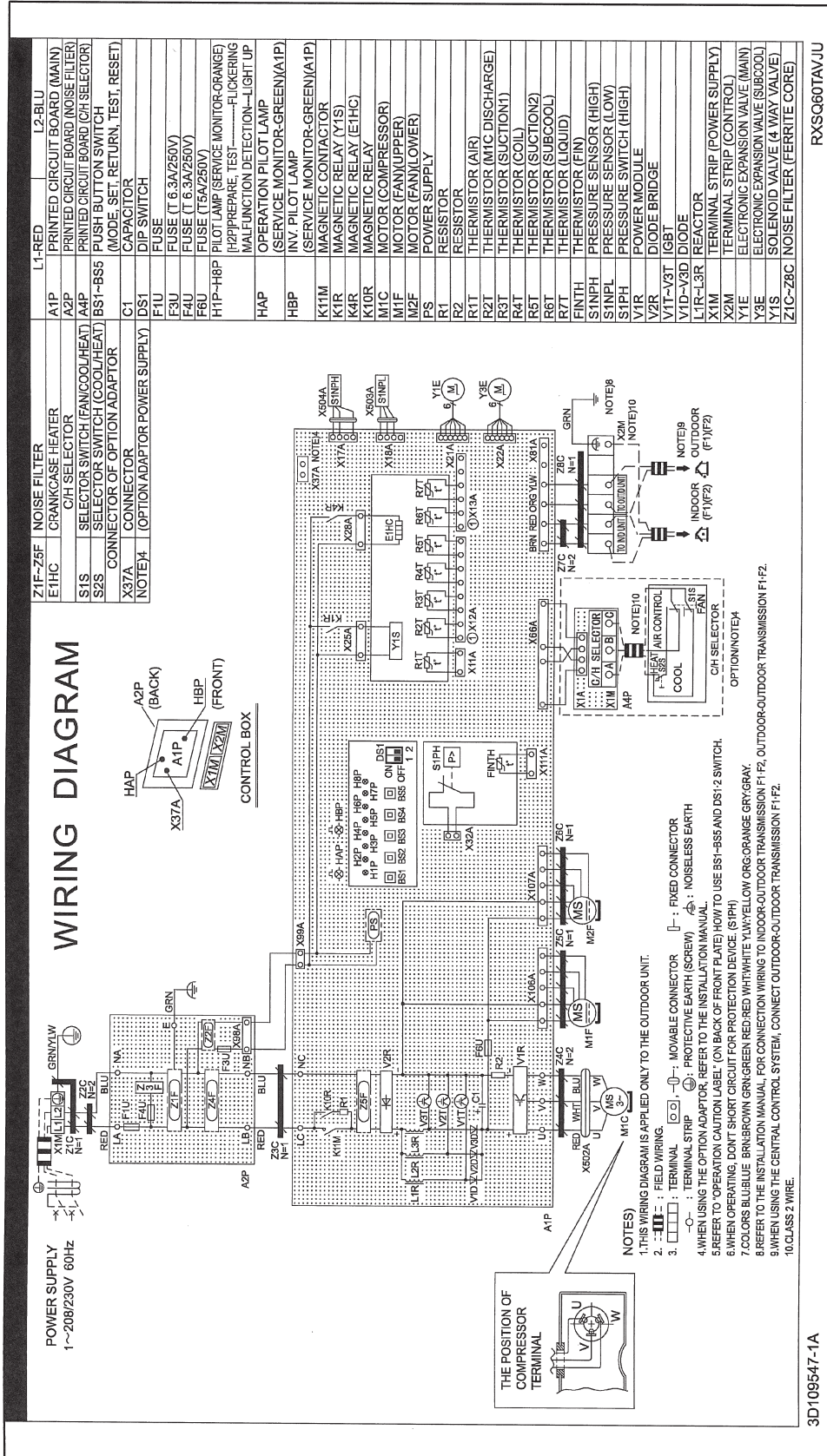

3D109547-1A

3D109547A

RXSQ60TAVJUA, RXSQ60TBVJUA

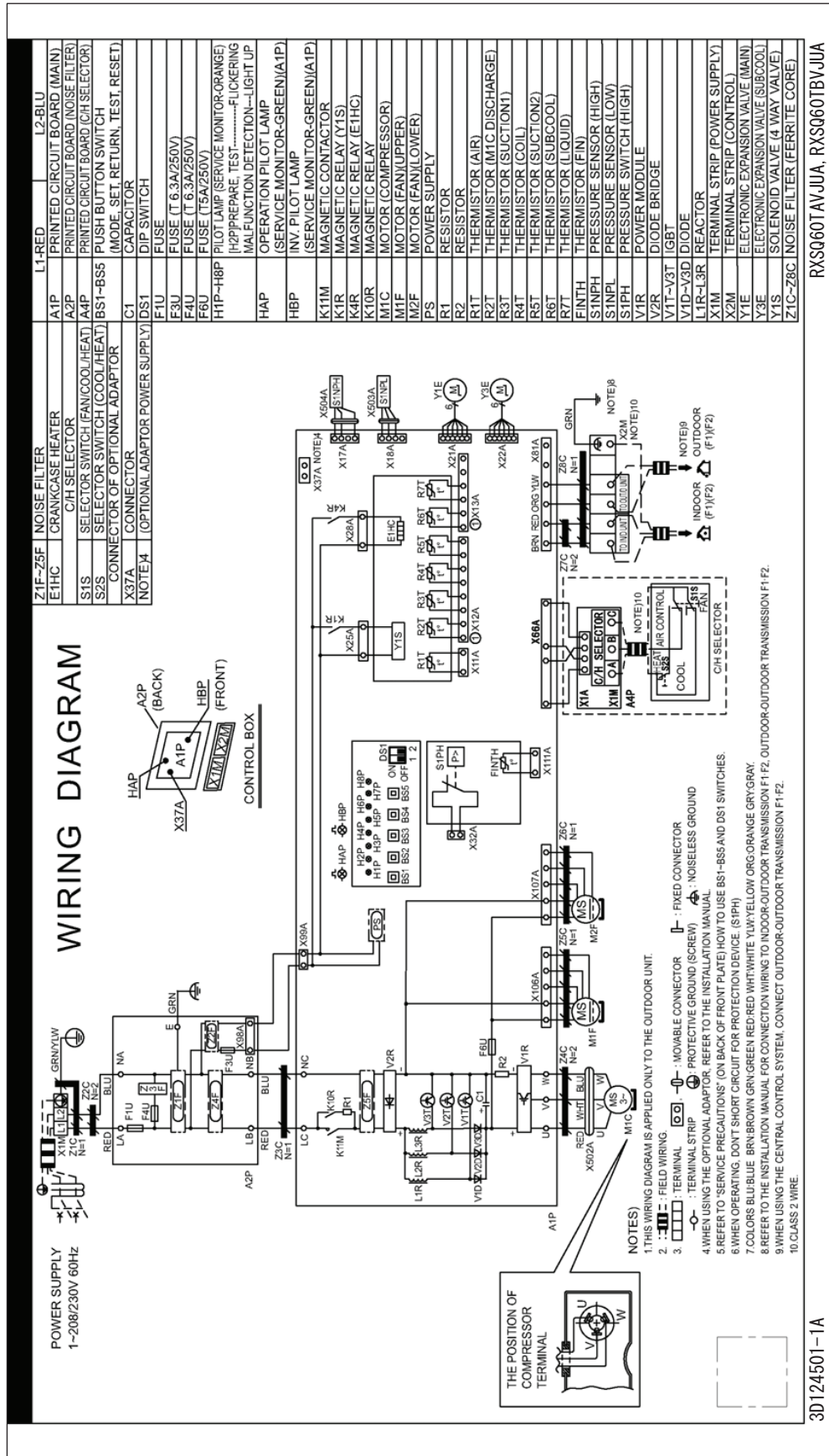

3D124501B

3D124501-1A

# 1.2 Indoor Unit

FXFQ07/09/12/15/18/24/30/36/48TVJU

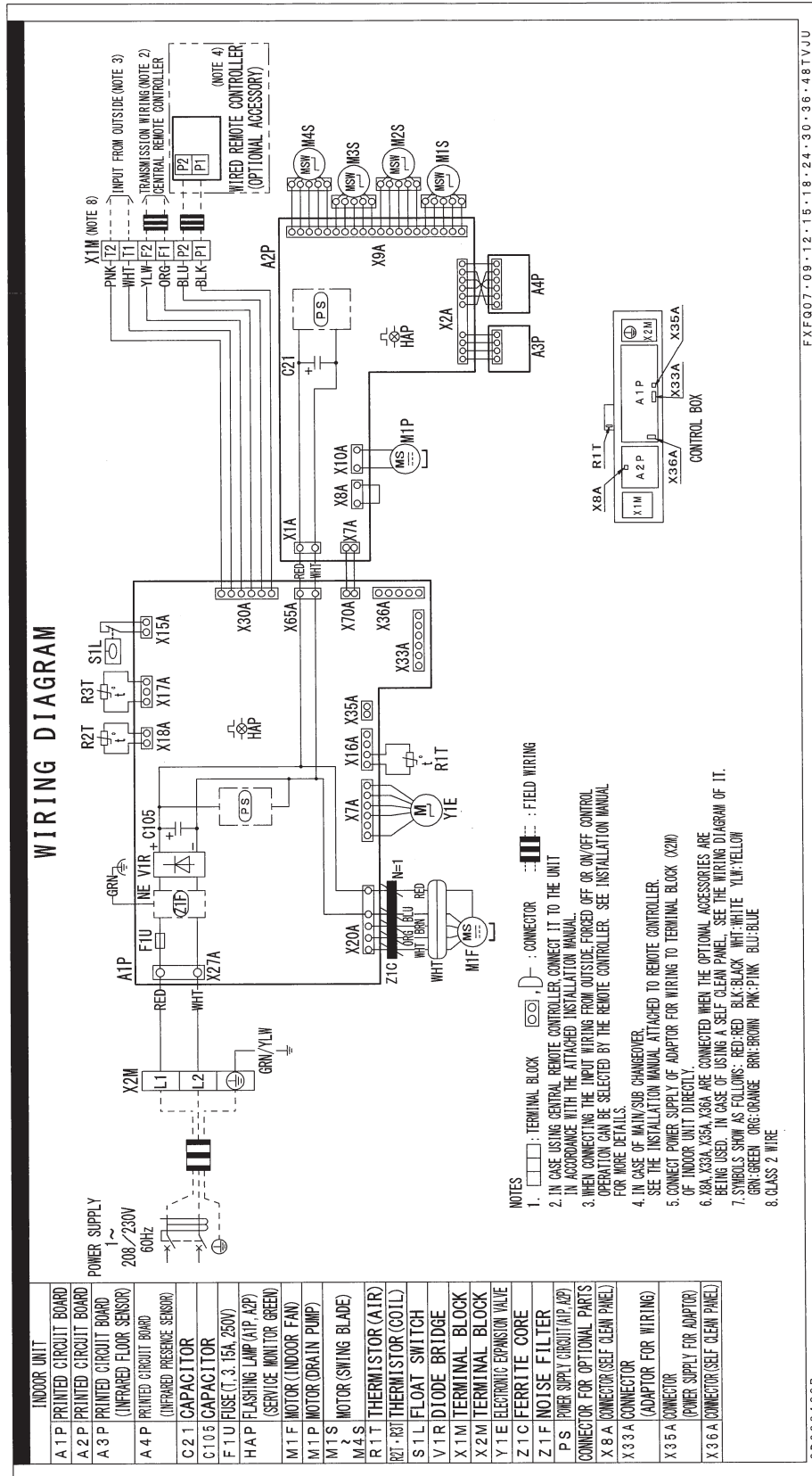

3D086460B

3D086460B

BYCQ125BGW1 (Self-Cleaning Decoration Panel for FXFQ-TVJU)

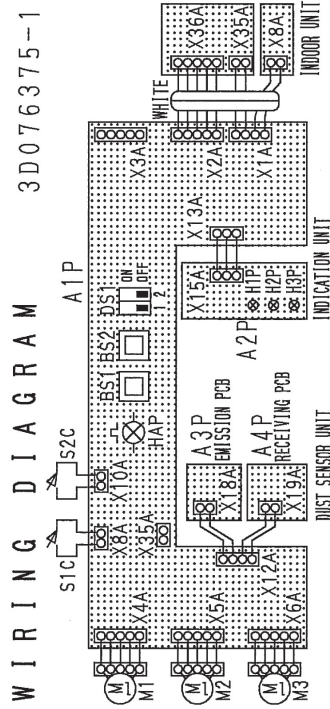

WIRING DIAGRAM 3D076375-1

BS1	PUSH BUTTON(FILTER AUTO CLEANING TEST)	HAP	LIGHT EMITTING DIODE(SERVICE MONITOR GREEN)
BS2	PUSH BUTTON(RESET OF ABNORMALITY INDICATION)	S1C	LIMIT SWITCH(FILTER)
DS1	DIP SWITCH(FILTER CLEANING PROHIBITION MODE)	S2C	LIMIT SWITCH(DAMPER)
H1P	LAMP(GREEN)	M1	MOTOR(FILTER)
H3P	LAMP(RED)	M2	MOTOR(BRUSH)
H2P	LAMP(RED)	M3	MOTOR(DAMPER)
		X35A	CONNECTOR(GROUP CONTROL ADAPTOR)

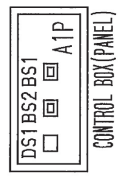

NOTE ) 1. -O- THESE SYMBOLS SHOW CONNECTORS.  
 2. WHEN DS1-1, -2 ARE TURNED ON, THEY WILL BE SET TO FILTER CLEANING PROHIBITION MODE AND INCREASE OF DUST DETECTION SENSOR LIGHT QUANTITY.  
 3. H1P AND H3P ARE NOT SET TO LIGHT WHEN SHIPPED FROM THE FACTORY.  
 4. POWER SUPPLY TO THE ADAPTOR WILL BE CONNECTED TO THE CONNECTOR(X35A) OF A1P.

3D076375A

FXFQ09/12/18/24/30/36/48PVJU

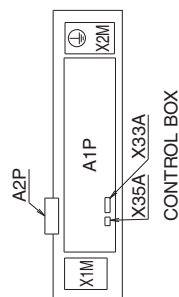
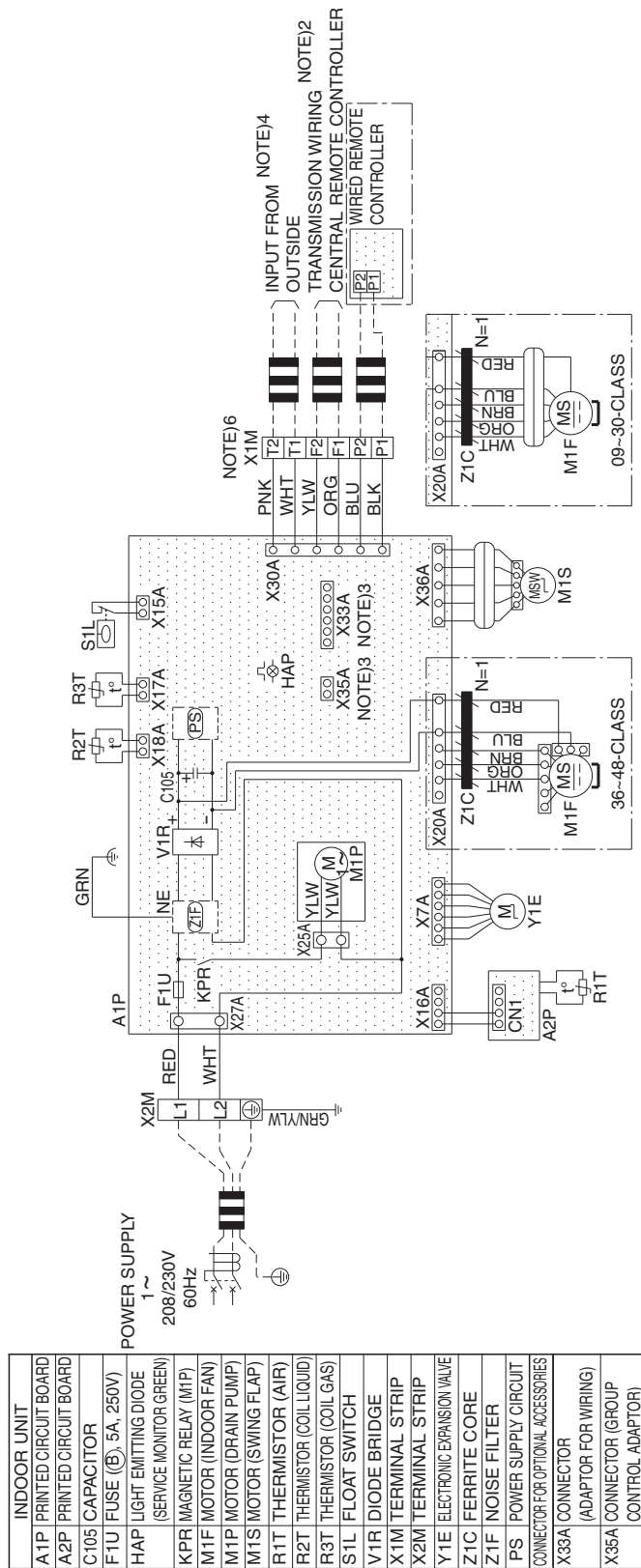

- NOTES**
1. □ : TERMINAL, □ : CONNECTOR, □ : FIELD WIRING, ⊕ : PROTECTIVE GROUND (SCREW), ⊕ : NOISELESS GROUND
  2. IN CASE USING CENTRAL REMOTE CONTROLLER, CONNECT IT TO THE UNIT IN ACCORDANCE WITH THE ATTACHED INSTALLATION MANUAL.
  3. X33A AND X35A ARE CONNECTED WHEN THE OPTIONAL ACCESSORIES ARE USED.
  4. WHEN CONNECTING THE INPUT WIRES FROM OUTSIDE, FORCED OFF OR ON/OFF CONTROL OPERATION CAN BE SELECTED BY THE REMOTE CONTROLLER. SEE INSTALLATION MANUAL FOR MORE DETAILS.
  5. SYMBOLS SHOW AS FOLLOWS:  
RED: RED BLK; BLACK WHT; WHITE YLW; YELLOW GRN; GREEN ORG; ORANGE BRN; BROWN PNK; PINK GRY; GRAY BLU; BLUE
  6. CLASS 2 WIRE

3D070301G





FXZQ05/07/09/12/15/18TBVJU

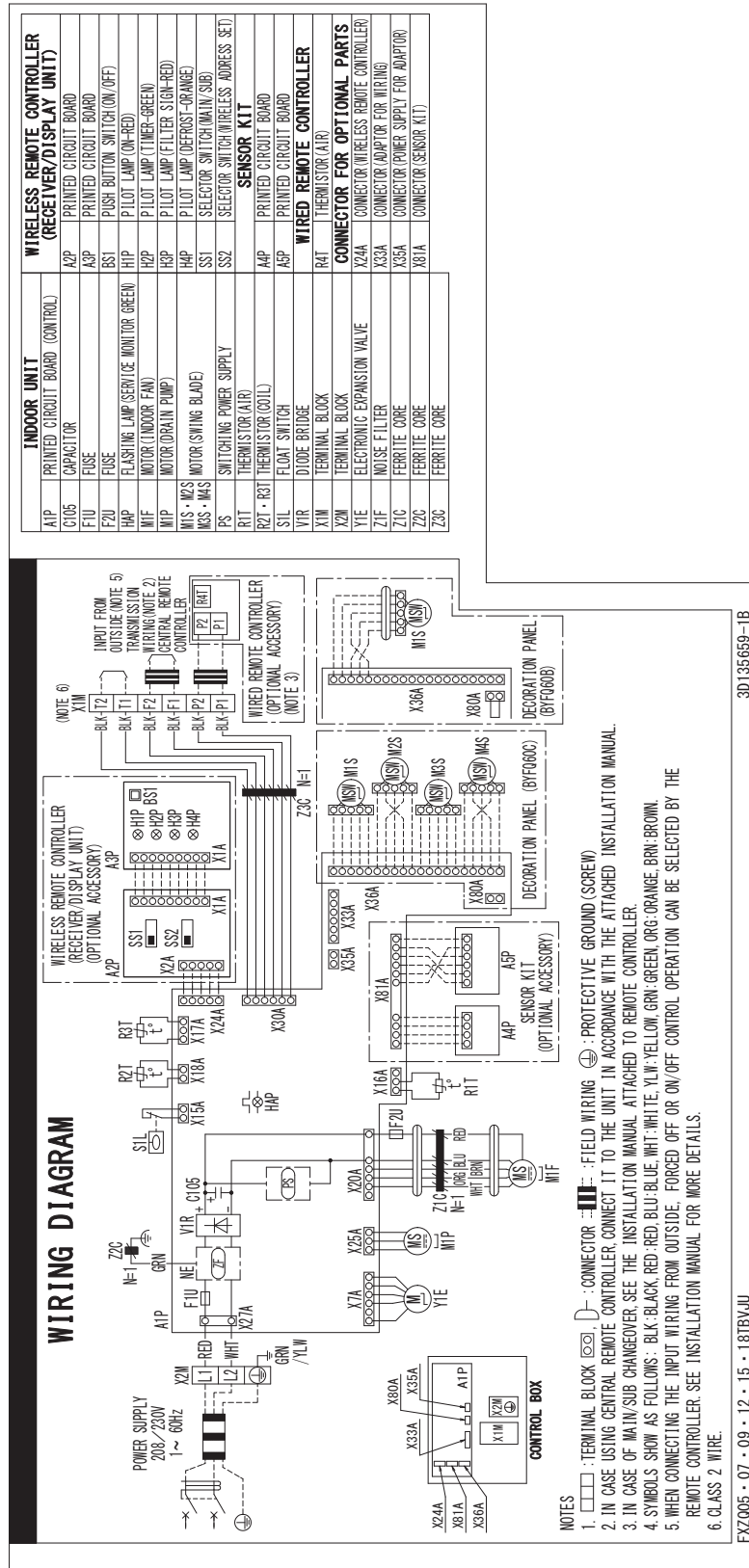

C: 3D135659C

FXZQ07/09/12/15/18MVJU9

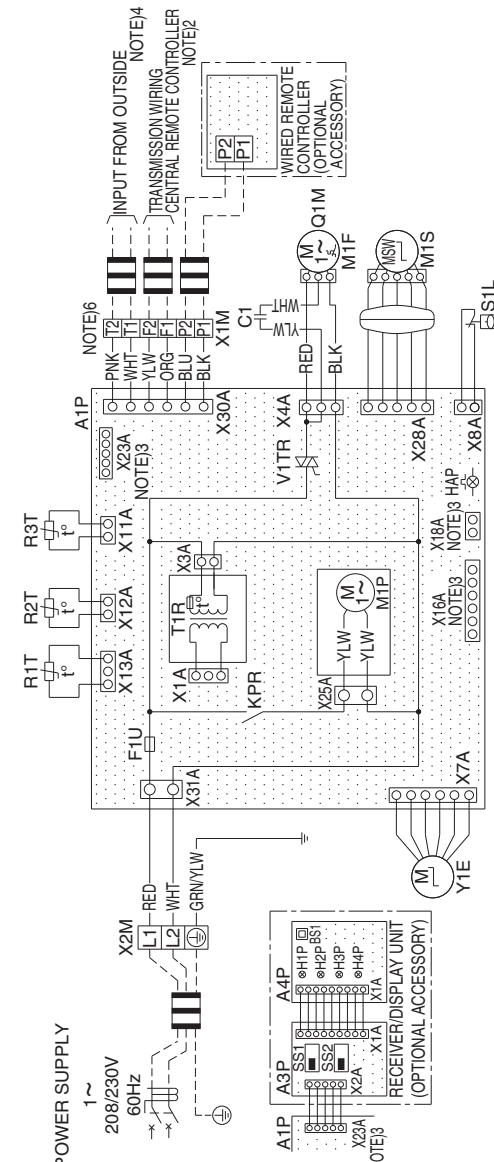

A1P	PRINTED CIRCUIT BOARD	BS1	BS BUTTON (ON/OFF)
C1	CAPACITOR (MIF)	H1P	PILOT LAMP (ON-RED)
HAP	FUSE (5A, 250V)	H2P	PILOT LAMP (TIMER-GREEN)
KPR	MAGNETIC RELAY (M1P)	H3P	PILOT LAMP (FILTER SIGN-RED)
M1P	FAN MOTOR	H4P	PILOT LAMP (DEFROST-ORANGE)
M1S	SWING LOUVER MOTOR	SS1	SELECTOR SWITCH (MAIN/SUB)
O1M	THERMAL PROTECTOR (MIF EMBEDDED)	SS2	SELECTOR SWITCH (WIRELESS ADDRESS SET)
R2T	THERMISTOR (COIL-LIQUID)	CON	CONNECTOR FOR OPTIONAL PARTS
R3T	THERMISTOR (COIL-GAS)	X16A	CONNECTOR (ADAPTOR FOR WIRING)
S1L	FLOAT SWITCH	X18A	CONNECTOR (WIRING ADAPTOR FOR ELECTRICAL APPENDICES)
T1TR	TRIAC	X23A	CONNECTOR (WIRELESS REMOTE CONTROLLER)
X1M	TERMINAL BLOCK	X23A	CONNECTOR (WIRELESS REMOTE CONTROLLER)
X2M	TERMINAL BLOCK	X23A	CONNECTOR (WIRELESS REMOTE CONTROLLER)
Y1E	ELECTRONIC EXPANSION VALVE	X23A	CONNECTOR (WIRELESS REMOTE CONTROLLER)
X3P	PRINTED CIRCUIT BOARD (RECEIVER/DISPLAY UNIT)	X23A	CONNECTOR (WIRELESS REMOTE CONTROLLER)
A3P	PRINTED CIRCUIT BOARD (RECEIVER/DISPLAY UNIT)	X23A	CONNECTOR (WIRELESS REMOTE CONTROLLER)
A4P	PRINTED CIRCUIT BOARD (RECEIVER/DISPLAY UNIT)	X23A	CONNECTOR (WIRELESS REMOTE CONTROLLER)

- NOTES
1. □ : TERMINAL  
 ○ : CONNECTOR  
 ≡≡≡ : FIELD WIRING  
 ⊕ : PROTECTIVE GROUND (SCREW)
  2. IN CASE USING CENTRAL REMOTE CONTROLLER, CONNECT IT TO THE UNIT IN ACCORDANCE WITH THE ATTACHED INSTALLATION MANUAL.
  3. X16A, X18A AND X23A ARE CONNECTED WHEN THE OPTIONAL ACCESSORIES ARE USED.
  4. WHEN CONNECTING THE INPUT WIRES FROM OUTSIDE, FORCED OFF OR ON/OFF CONTROL OPERATION CAN BE SELECTED BY REMOTE CONTROLLER. IN DETAILS, REFER TO THE INSTALLATION MANUAL ATTACHED TO THE UNIT.
  5. SYMBOLS SHOW AS FOLLOWS: RED: RED BLK; BLACK WHT; WHITE YLW; YELLOW PNK; PINK ORG; ORANGE GRN; GREEN BLU; BLUE
  6. CLASS 2 WIRE

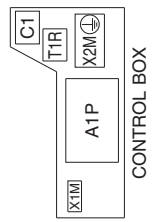

3D080350C

FXUQ18/24/30/36PVJU

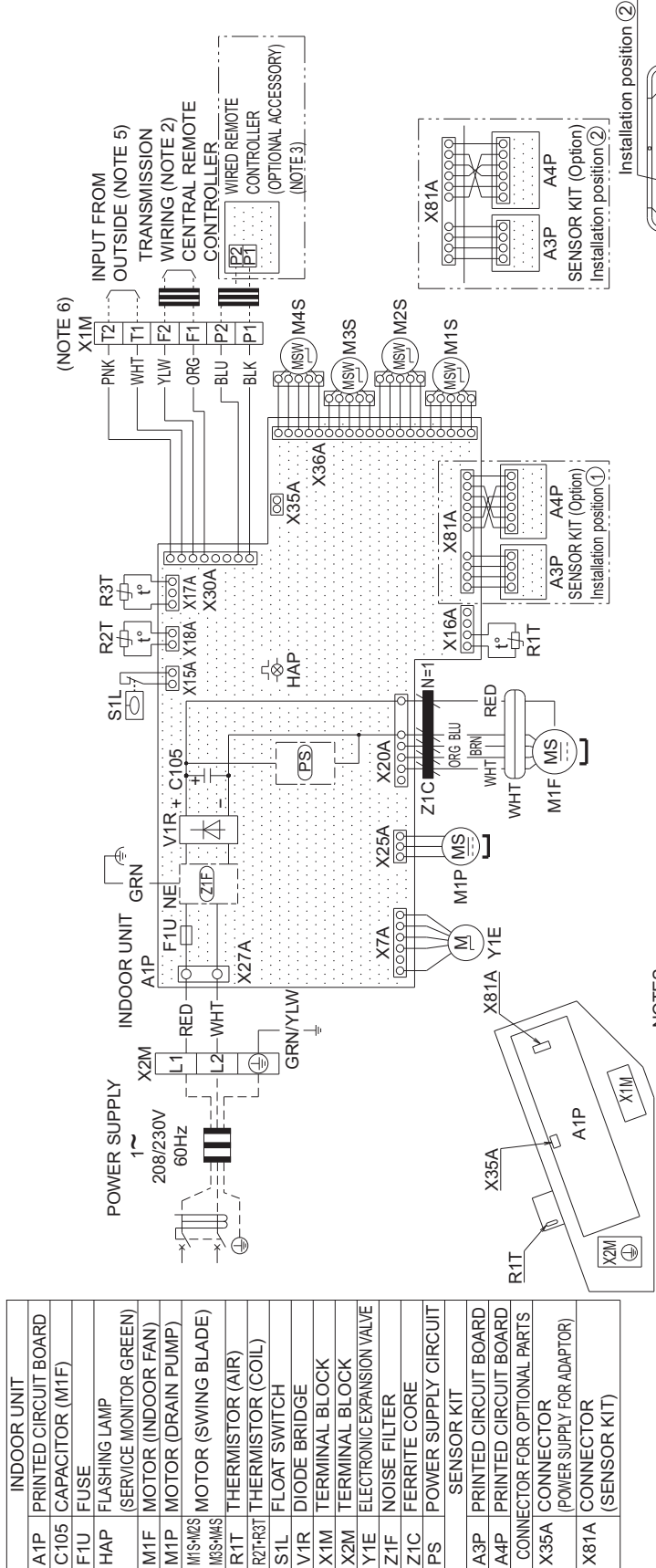

NOTES

1. : TERMINAL BLOCK : CONNECTOR : FIELD WIRING
2. IN CASE USING CENTRAL REMOTE CONTROLLER, CONNECT IT TO THE UNIT IN ACCORDANCE WITH THE ATTACHED INSTALLATION MANUAL.
3. IN CASE OF MAIN/SUB CHANGEOVER, SEE THE INSTALLATION MANUAL ATTACHED TO REMOTE CONTROLLER.
4. SYMBOLS SHOW AS FOLLOWS: BLK: BLACK; RED: RED; BLU: BLUE; WHT: WHITE; YLW: YELLOW; GRN: GREEN; ORG: ORANGE; BRN: BROWN; PNK: PINK
5. WHEN CONNECTING THE INPUT WIRING FROM OUTSIDE, FORCED OFF OR ON/OFF CONTROL OPERATION CAN BE SELECTED BY THE REMOTE CONTROLLER. SEE INSTALLATION MANUAL FOR MORE DETAILS.
6. CLASS 2 WIRE

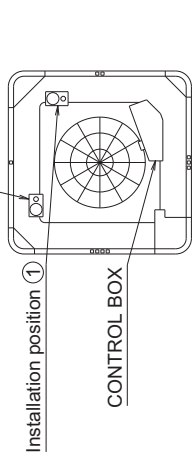

Installation position of SENSOR KIT

A1P	INDOOR UNIT PRINTED CIRCUIT BOARD
C105	CAPACITOR (M1F)
F1U	FUSE
HAP	FLASHING LAMP (SERVICE MONITOR GREEN)
M1F	MOTOR (INDOOR FAN)
M1P	MOTOR (DRAIN PUMP)
M1S/M2S	MOTOR (SWING BLADE)
M3S/M4S	THERMISTOR (AIR)
R1T	THERMISTOR (COIL)
R2T/R3T	FLOAT SWITCH
S1L	DIODE BRIDGE
V1R	TERMINAL BLOCK
X1M	TERMINAL BLOCK
X2M	ELECTRONIC EXPANSION VALVE
Y1E	NOISE FILTER
Z1F	FERRITE CORE
Z1C	POWER SUPPLY CIRCUIT
PS	SENSOR KIT
A3P	PRINTED CIRCUIT BOARD
A4P	CONNECTOR FOR OPTIONAL PARTS
X35A	CONNECTOR (POWER SUPPLY FOR ADAPTOR)
X81A	CONNECTOR (SENSOR KIT)

FXUQ18/24/30/36PAVJU

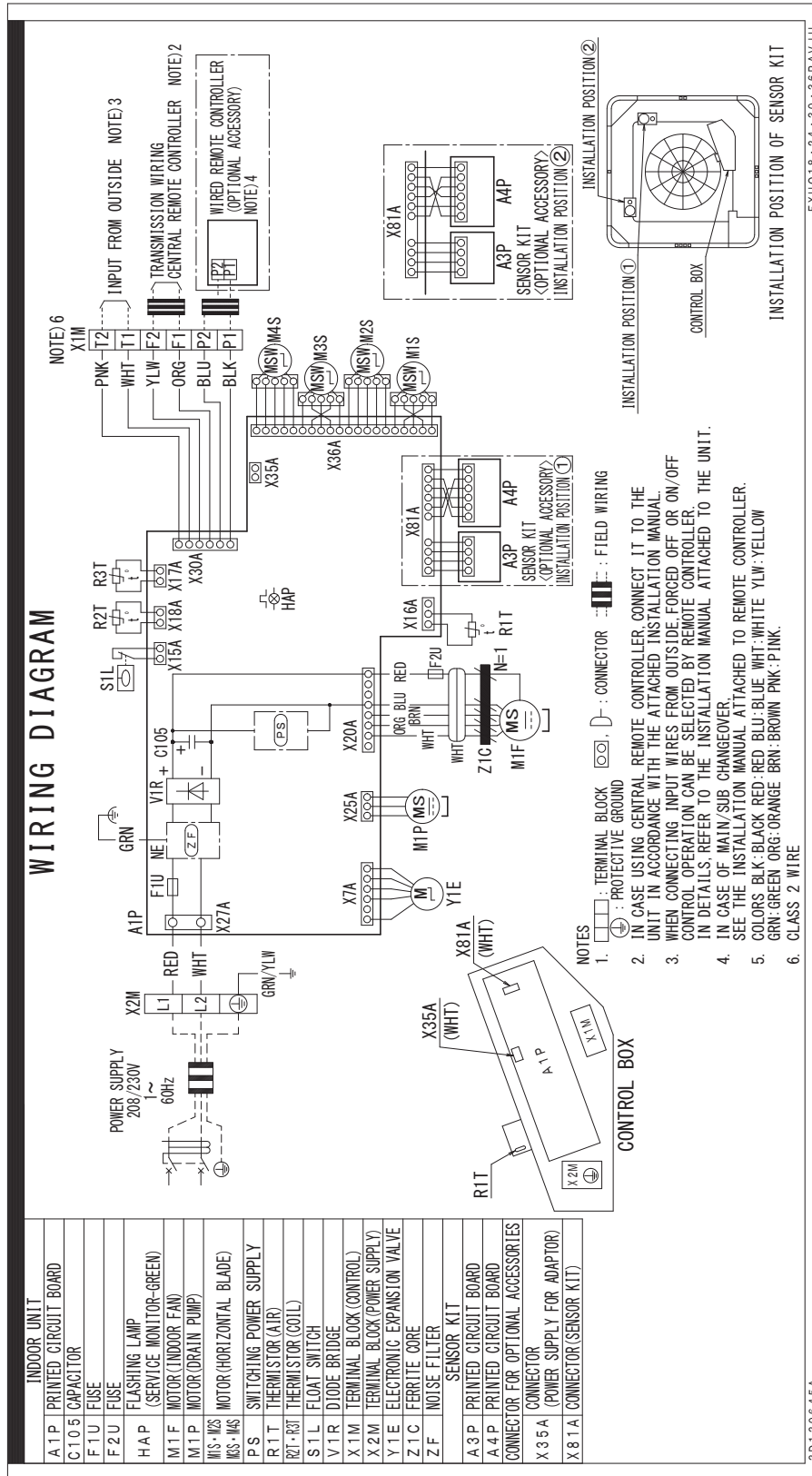

FXUQ18・24・30・36PAVJU

3D130645A



FXDQ07/09/12/18/24MVJU

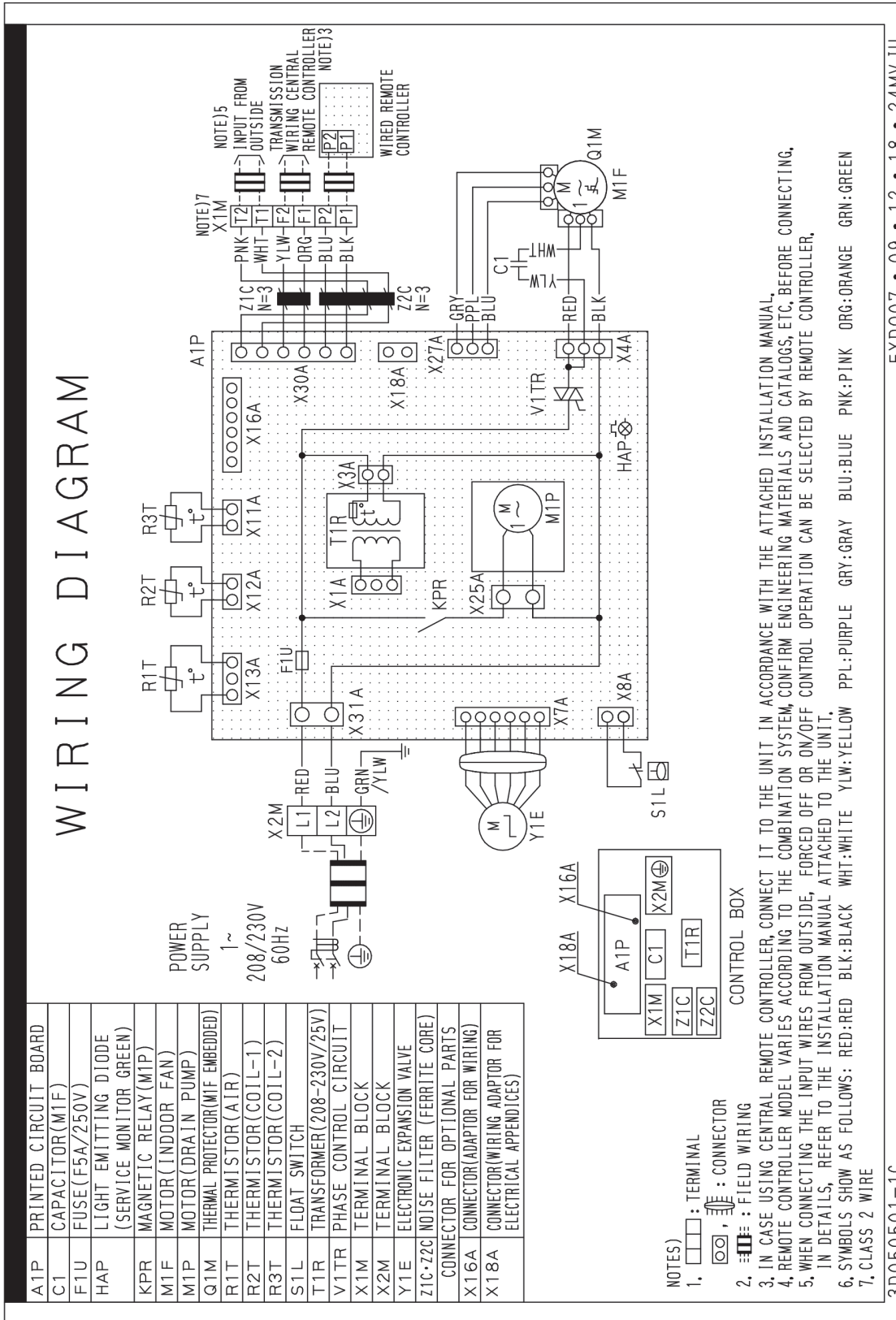

C: 3D050501C

FXDQ07 • 09 • 12 • 18 • 24MVJU

FXSQ05/07/09/12/15/18/24/30/36/48/54TAVJU

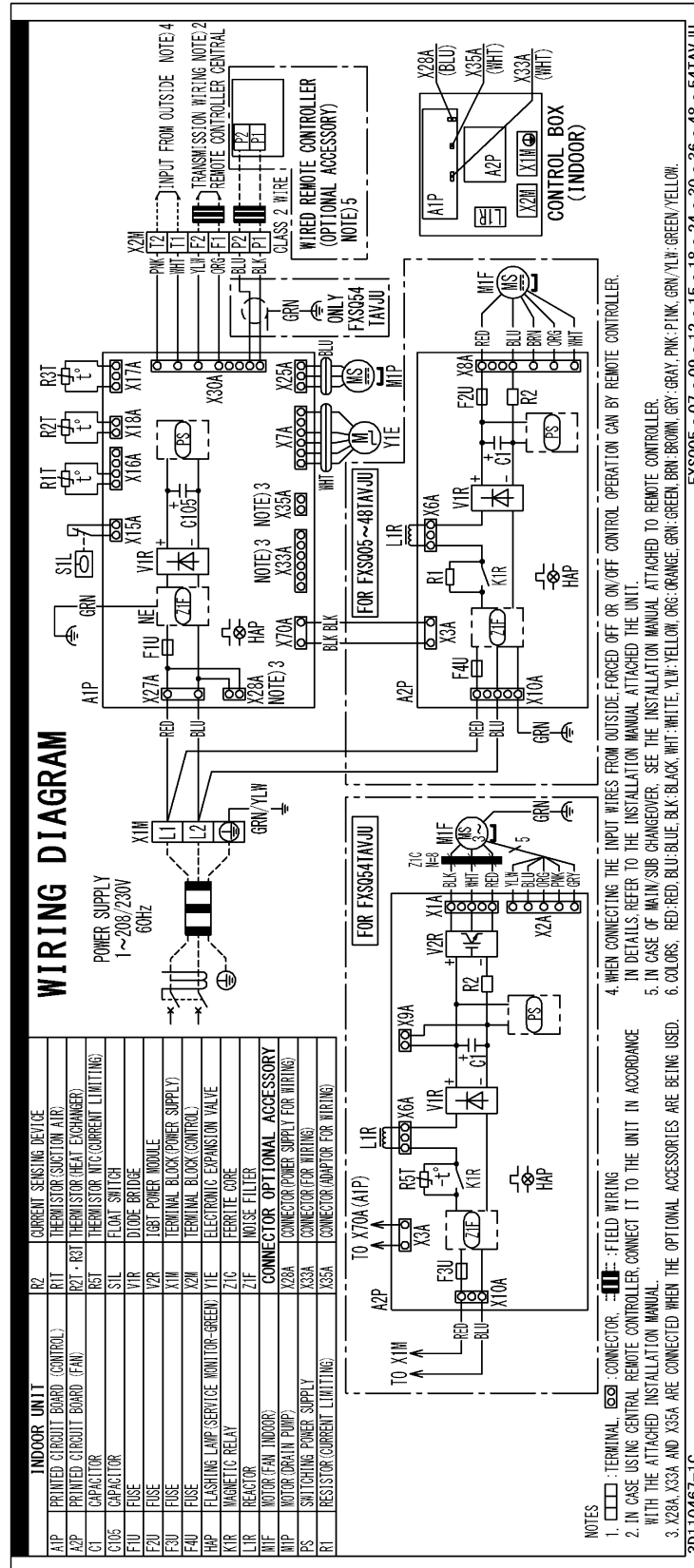

C: 3D110467C

FXSQ05/07/09/12/15/18/24/30/36/48/54TBVJU

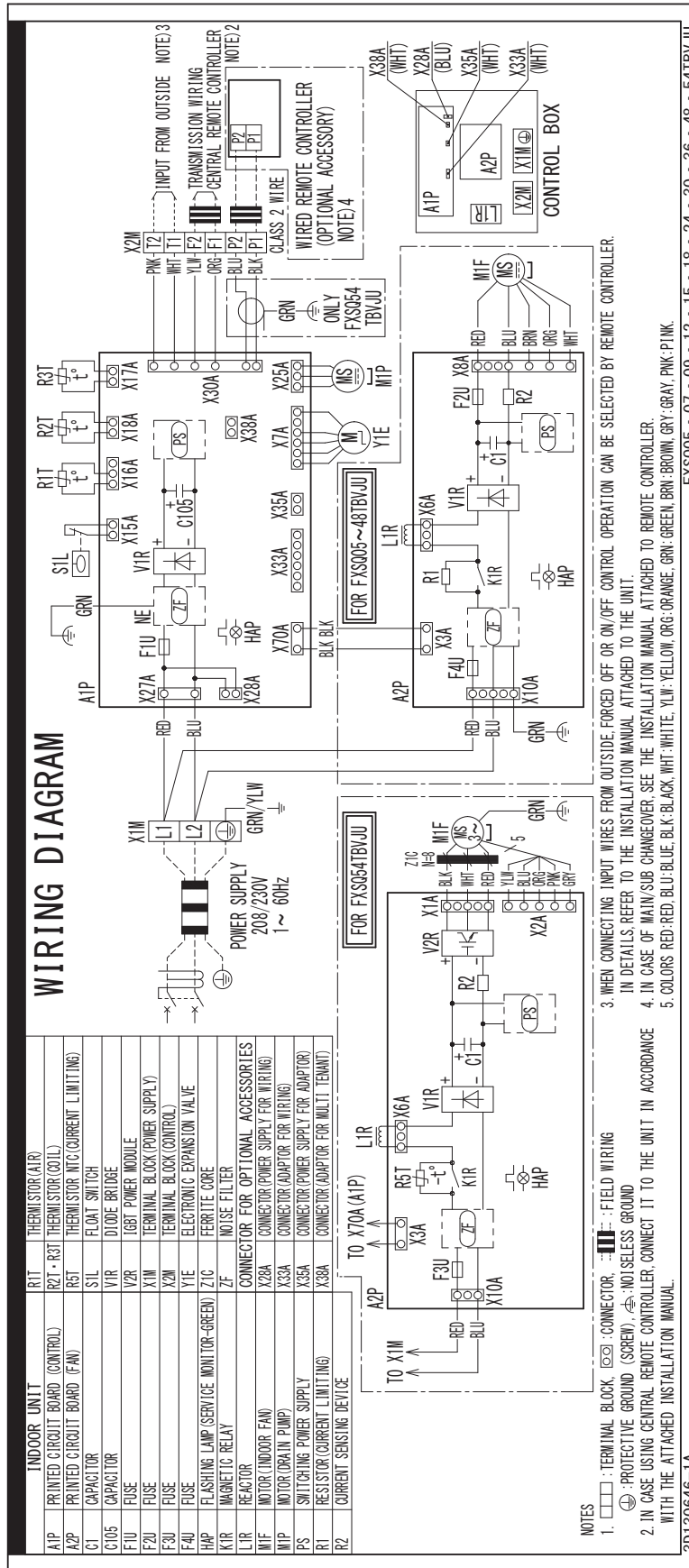

3D130646B



FXMQ07/09/12/15/18/24/30/36/48/54PBVJU

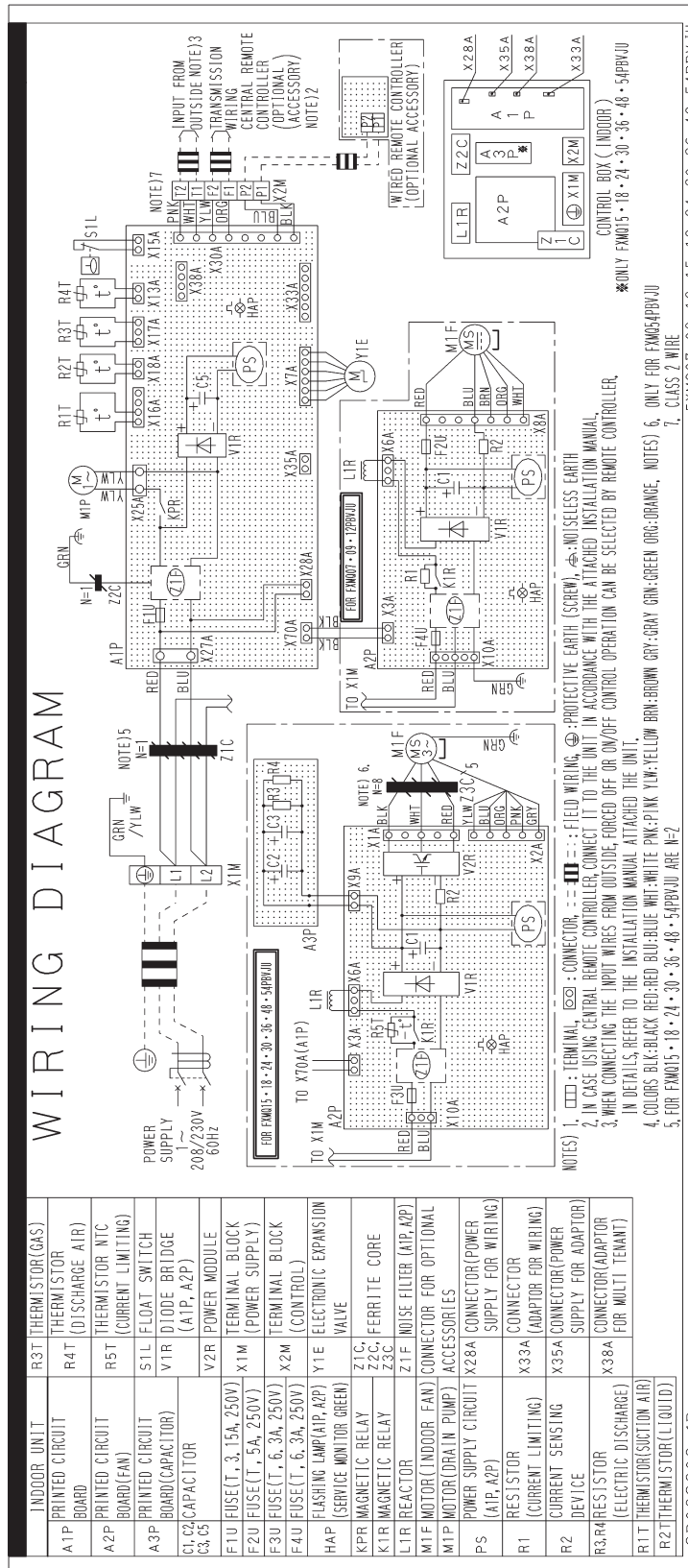

3D093209B

FXMQ15/18/24/30/36/48/54TBVJU

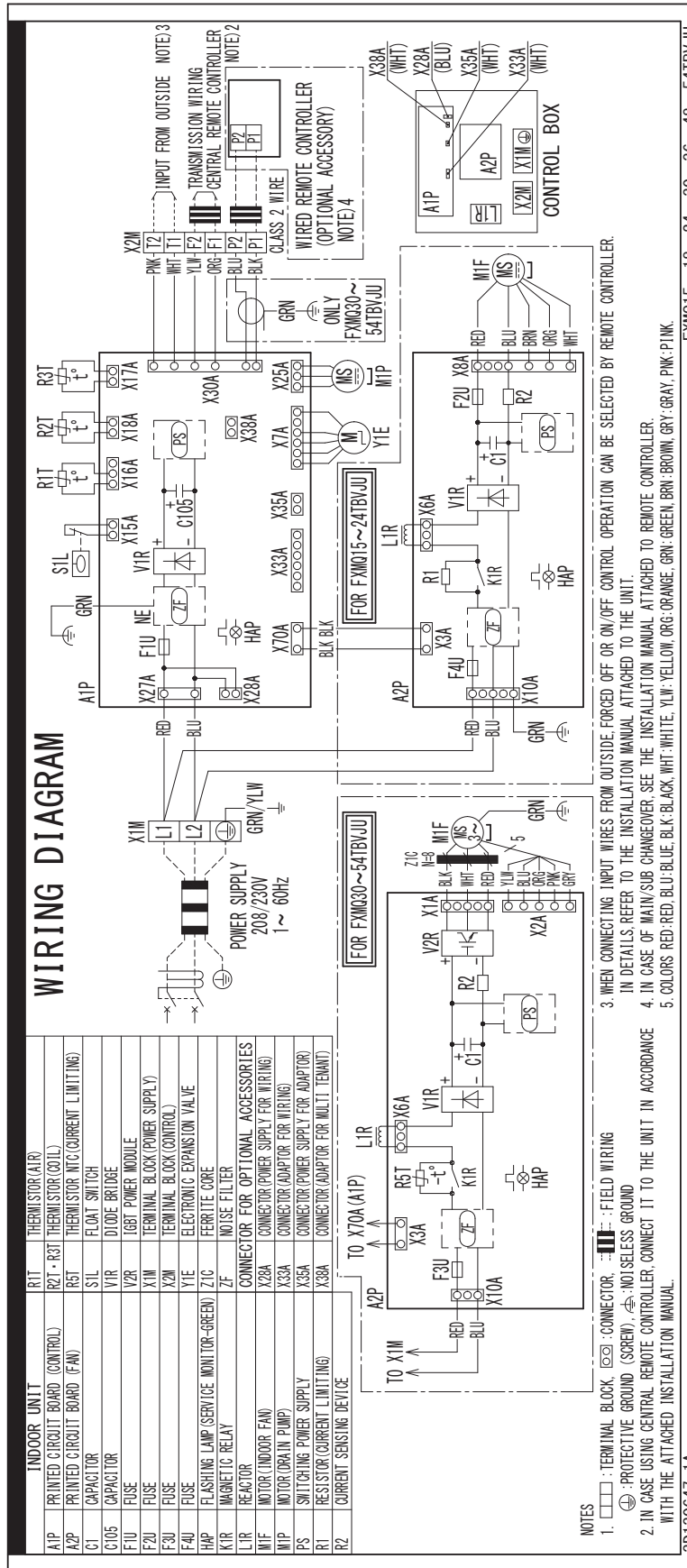

3D130647B



FXAQ07/09/12/18/24PVJU

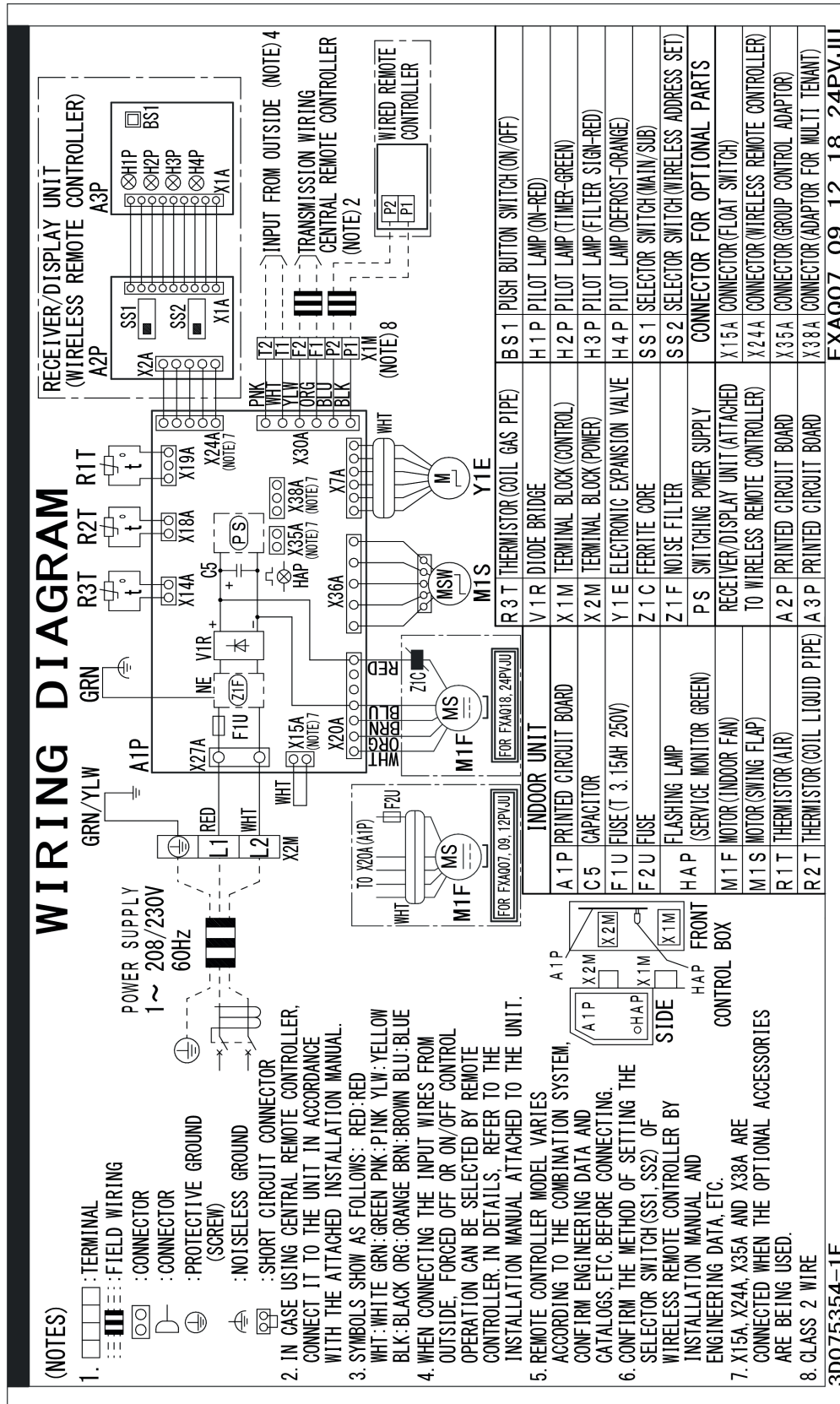

3D075354F



FXTQ09/12/18/24/30/36/42/48/54/60TAVJUA(D)

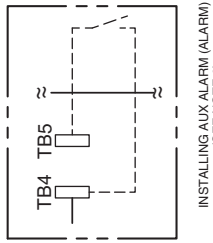
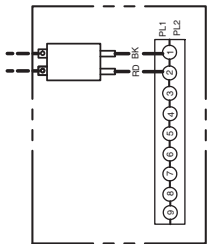
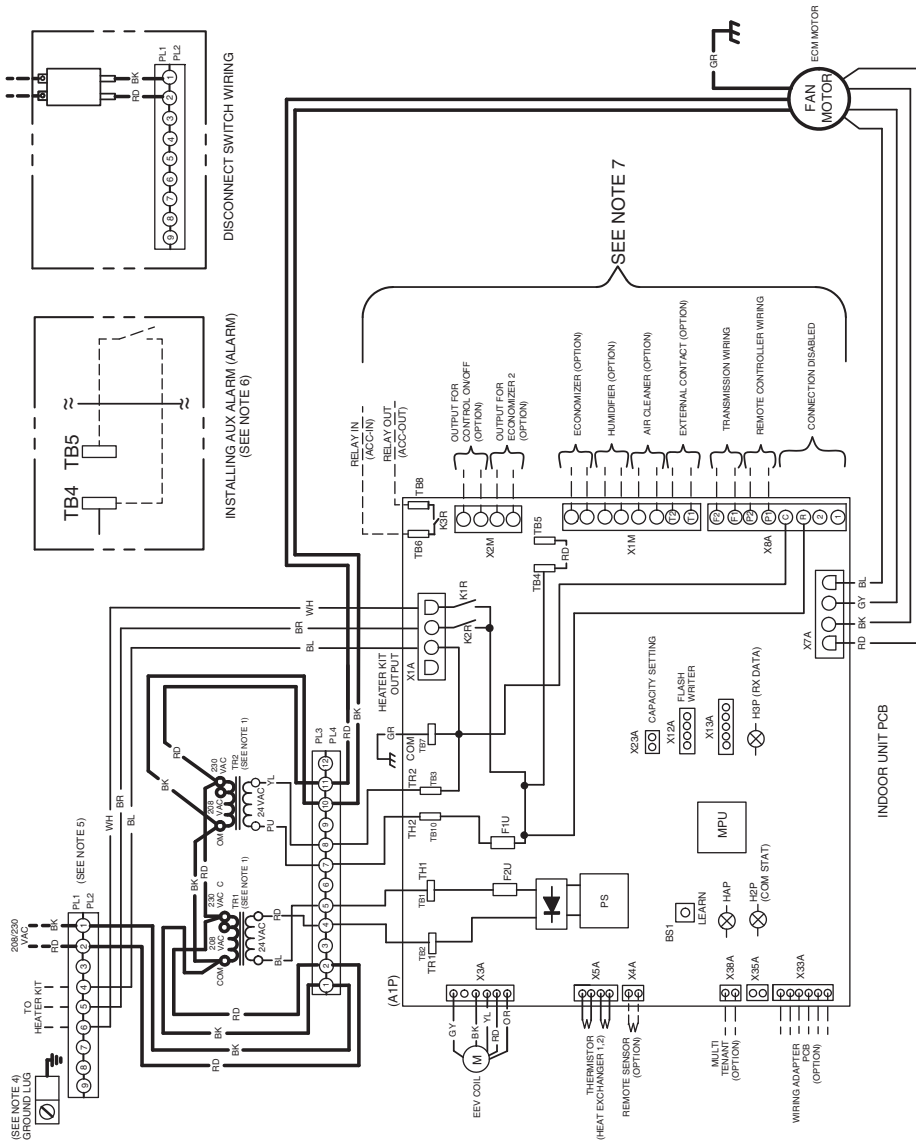

**INTEGRATED CONTROL:**

LOW VOLTAGE ———

LOW VOLTAGE FIELD - - -

HIGH VOLTAGE ———

HIGH VOLTAGE FIELD - - -

JUNCTION —

TERMINAL —

PLUG CONNECTION —

EQUIPMENT GND —

FIELD GROUND —

**COLOR CODES:**

BL - BLUE

RD - RED

YL - YELLOW

OR - ORANGE

BK - BLACK

GY - GREY

BR - BROWN

GR - GREEN

WH - WHITE

PU - PURPLE

**COMPONENT CODES:**

PL1, PL2 — POWER/HEATER KIT/ DISCONNECT SWITCH CONNECTOR

TR1, TR2 — TRANSFORMER

F1U, F2U — FUSE LINK

PL3, PL4 — TRANSFORMER CONNECTOR

- NOTES:**
1. PLACE RED WIRES ON 208 V TERMINAL OF 2-TRANSFORMER (TR1/TR2) FOR 208 VAC OPERATION.
  2. MANUFACTURERS SPECIFIED REPLACEMENT PARTS MUST BE USED WHEN SERVICING.
  3. IF ANY OF THE ORIGINAL WIRES AS SUPPLIED WITH THIS UNIT MUST BE REPLACED, IT MUST BE REPLACED WITH WIRING MATERIAL HAVING A TEMPERATURE RATING OF AT LEAST 105°C. USE COPPER CONDUCTORS ONLY.
  4. UNIT MUST BE PERMANENTLY GROUNDED AND CONFIRM TO N.E.C AND LOCAL CODES.
  5. DISCARD CONNECTOR PL1 WHEN INSTALLING OPTIONAL HEAT KIT.
  6. REMOVE SHORT RED CIRCUITING WIRE AND PUT AUX ALARM SWITCH WHEN INSTALLING AUX. ALARM SWITCH.
  7. USE N.E.C CLASS 2 WIRE.

C: 0140A00500A

CXTQ24/36/48/60TASBLU

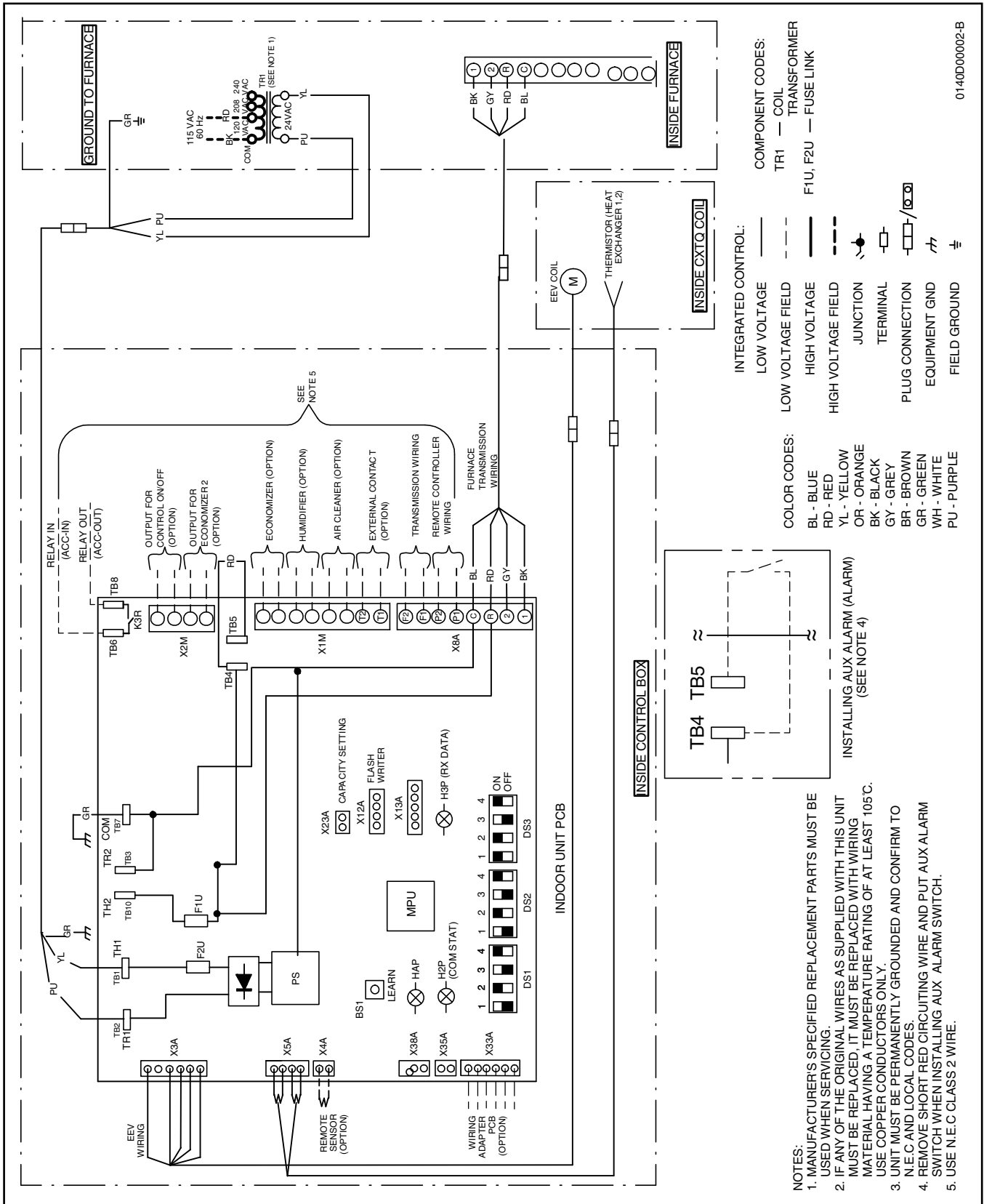

0140D00002-B

# 1.3 Air Treatment Equipment

## 1.3.1 Outdoor-Air Processing Unit

FXMQ48/72MFVJU

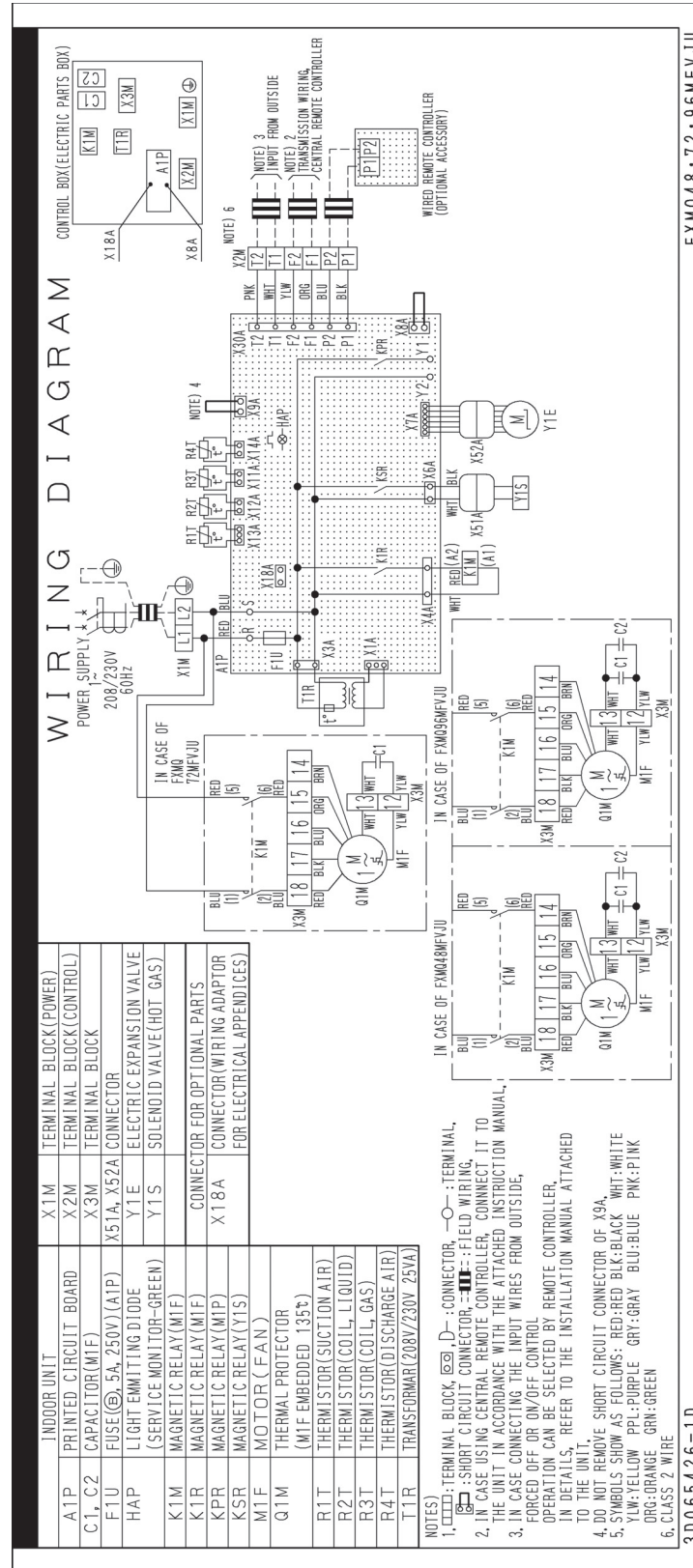

FXMQ48 • 72 • 96MFVJU

3D065426D





VAM1200GVJU

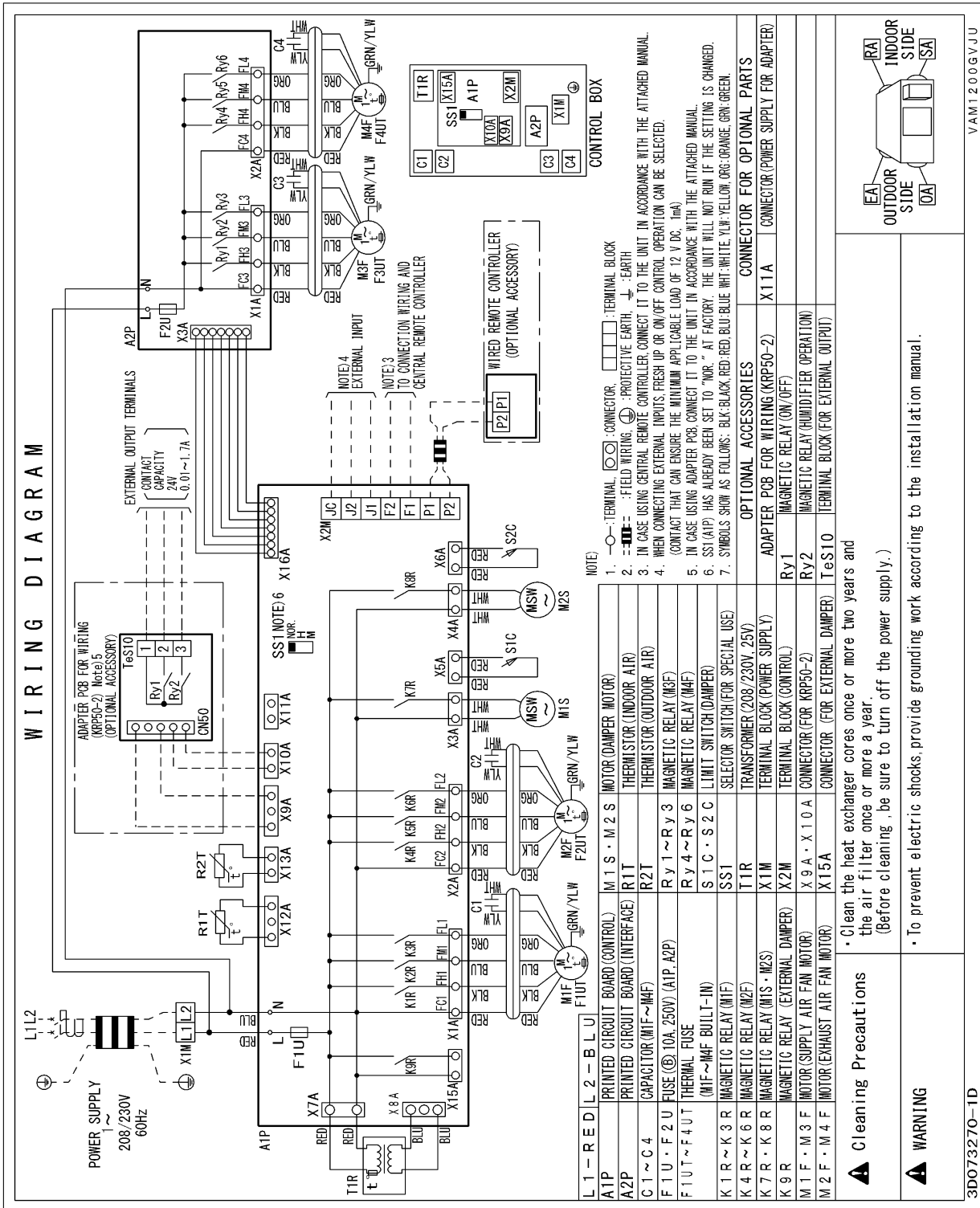

3D073270D

VAM1200GVJU

**Warning**

- Daikin products are manufactured for export to numerous countries throughout the world. Prior to purchase, please confirm with your local authorized importer, distributor and/or retailer whether this product conforms to the applicable standards, and is suitable for use, in the region where the product will be used. This statement does not purport to exclude, restrict or modify the application of any local legislation.
- Ask a qualified installer or contractor to install this product. Do not try to install the product yourself. Improper installation can result in water or refrigerant leakage, electrical shock, fire or explosion.
- Use only those parts and accessories supplied or specified by Daikin. Ask a qualified installer or contractor to install those parts and accessories. Use of unauthorized parts and accessories or improper installation of parts and accessories can result in water or refrigerant leakage, electrical shock, fire or explosion.
- Read the user's manual carefully before using this product. The user's manual provides important safety instructions and warnings. Be sure to follow these instructions and warnings.

If you have any inquiries, please contact your local importer, distributor and/or retailer.

**Cautions on product corrosion**

1. Air conditioners should not be installed in areas where corrosive gases, such as acid gas or alkaline gas, are produced.
2. If the outdoor unit is to be installed close to the sea shore, direct exposure to the sea breeze should be avoided. If you need to install the outdoor unit close to the sea shore, contact your local distributor.

©All rights reserved