

Engineering Data

Wall Mounted Type

FXAQ-PVJU

60 Hz

R-410A



Table of Contents

1. Specifications	2
2. Dimensions.....	5
3. Piping Diagrams	8
4. Wiring Diagrams.....	9
5. Electric Characteristics.....	11
6. Safety Devices Setting	12
7. Capacity Tables	13
7.1 Cooling Capacity at Te: 43°F (6°C).....	13
7.2 Heating Capacity.....	13
7.3 Correction Factor for Cooling Capacity at Te: 48°F (9°C).....	13
8. Air Velocity and Temperature Distributions (Reference Data)	14
8.1 Cooling Mode.....	14
8.2 Heating Mode.....	19
9. Sound Levels (Reference Data).....	24

1. Specifications

Wall mounted type

Model		FXAQ07PVJU		FXAQ09PVJU	
Power supply		1 phase, 208/230 V, 60 Hz		1 phase, 208/230 V, 60 Hz	
★1, ★3 Cooling capacity	Btu/h	7,500		9,500	
★2, ★3 Heating capacity	Btu/h	8,500		10,500	
Casing/Color		White (3.0Y8.5/0.5)		White (3.0Y8.5/0.5)	
Dimensions: (H × W × D)		in.	11-3/8 × 31-1/4 × 9-1/4		11-3/8 × 31-1/4 × 9-1/4
Coil (cross fin coil)	Rows × Stages × FPI	2 × 14 × 17		2 × 14 × 17	
	Face area	ft ²	1.73	1.73	
Fan	Model		QCL9661M	QCL9661M	
	Type		Cross flow fan	Cross flow fan	
	Motor output	W	40	40	
	Air flow rate (H/L)	cfm	260/160	280/175	
	Drive		Direct drive	Direct drive	
Temperature control		Microprocessor thermostat for cooling and heating		Microprocessor thermostat for cooling and heating	
Sound absorbing thermal insulation material		Foamed polystyrene / Foamed polyethylene		Foamed polystyrene / Foamed polyethylene	
Air filter		Resin net (washable)		Resin net (washable)	
★4 Sound pressure level (reference data) (H/L)	dB(A)	36/31		37/31	
Weight		lbs	26	26	
Piping connections	Liquid pipes	in.	φ1/4 (flare connection)	φ1/4 (flare connection)	
	Gas pipes	in.	φ1/2 (flare connection)	φ1/2 (flare connection)	
	Drain pipe	in.	VP13 (external dia. 11/16, internal dia. 1/2)	VP13 (external dia. 11/16, internal dia. 1/2)	
Safety devices		Fuse		Fuse	
Refrigerant control		Electronic expansion valve		Electronic expansion valve	
Connectable outdoor unit		R410A VRV series		R410A VRV series	
Standard accessories		Operation manual, Installation manual, Installation panel, Paper pattern for installation, Insulation tape, Insulation tube, Clamps, Screws		Operation manual, Installation manual, Installation panel, Paper pattern for installation, Insulation tape, Insulation tube, Clamps, Screws	

Note:

- ★1. Nominal cooling capacities are based on the following conditions:
 Return air temperature: 80°FDB, 67°FWB
 Outdoor temperature: 95°FDB
 Equivalent refrigerant piping length: 25 ft (horizontal)
- ★2. Nominal heating capacities are based on the following conditions:
 Return air temperature: 70°FDB.
 Outdoor temperature: 47°FDB, 43°FWB
 Equivalent refrigerant piping length: 25 ft (horizontal)
- ★3. Capacities are net, including a deduction for cooling (an addition for heating) for indoor fan motor heat.
- ★4. Anechoic chamber conversion value, measured under JIS conditions. During actual operation, these values may be higher as a result of installation conditions.

C: 3D075572A

Wall mounted type

Model		FXAQ12PVJU		FXAQ18PVJU		
Power supply		1 phase, 208/230 V, 60 Hz		1 phase, 208/230 V, 60 Hz		
★1, ★3 Cooling capacity	Btu/h	12,000		18,000		
★2, ★3 Heating capacity	Btu/h	13,500		20,000		
Casing/Color		White (3.0Y8.5/0.5)		White (3.0Y8.5/0.5)		
Dimensions: (H × W × D)		in.	11-3/8 × 31-1/4 × 9-1/4	11-3/8 × 41-3/8 × 9-1/4		
Coil (cross fin coil)	Rows × Stages × FPI		2 × 14 × 17		2 × 14 × 17	
	Face area	ft ²	1.73		2.29	
Fan	Model		QCL9661M		QCL9686M	
	Type		Cross flow fan		Cross flow fan	
	Motor output	W	40		43	
	Air flow rate (H/L)	cfm	290/180		500/400	
	Drive		Direct drive		Direct drive	
Temperature control		Microprocessor thermostat for cooling and heating		Microprocessor thermostat for cooling and heating		
Sound absorbing thermal insulation material		Foamed polystyrene / Foamed polyethylene		Foamed polystyrene / Foamed polyethylene		
Air filter		Resin net (washable)		Resin net (washable)		
★4 Sound pressure level (reference data) (H/L)	dB(A)	38/31		43/37		
Weight		lbs	26		31	
Piping connections	Liquid pipes	in.	ϕ1/4 (flare connection)		ϕ1/4 (flare connection)	
	Gas pipes	in.	ϕ1/2 (flare connection)		ϕ1/2 (flare connection)	
	Drain pipe	in.	VP13 (external dia. 11/16, internal dia. 1/2)		VP13 (external dia. 11/16, internal dia. 1/2)	
Safety devices		Fuse		Fuse		
Refrigerant control		Electronic expansion valve		Electronic expansion valve		
Connectable outdoor unit		R410A VRV series		R410A VRV series		
Standard accessories		Operation manual, Installation manual, Installation panel, Paper pattern for installation, Insulation tape, Insulation tube, Clamps, Screws		Operation manual, Installation manual, Installation panel, Paper pattern for installation, Insulation tape, Insulation tube, Clamps, Screws		

Note:

- ★1. Nominal cooling capacities are based on the following conditions:
Return air temperature: 80°FDB, 67°FWB
Outdoor temperature: 95°FDB
Equivalent refrigerant piping length: 25 ft (horizontal)
- ★2. Nominal heating capacities are based on the following conditions:
Return air temperature: 70°FDB.
Outdoor temperature: 47°FDB, 43°FWB
Equivalent refrigerant piping length: 25 ft (horizontal)
- ★3. Capacities are net, including a deduction for cooling (an addition for heating) for indoor fan motor heat.
- ★4. Anechoic chamber conversion value, measured under JIS conditions. During actual operation, these values may be higher as a result of installation conditions.

C: 3D075572A

Wall mounted type

Model			FXAQ24PVJU
Power supply			1 phase, 208/230 V, 60 Hz
★1, ★3 Cooling capacity	Btu/h		24,000
★2, ★3 Heating capacity	Btu/h		26,500
Casing/Color			White (3.0Y8.5/0.5)
Dimensions: (H × W × D)		in.	11-3/8 × 41-3/8 × 9-1/4
Coil (cross fin coil)	Rows × Stages × FPI		2 × 14 × 17
	Face area	ft ²	2.29
Fan	Model		QCL9686M
	Type		Cross flow fan
	Motor output	W	43
	Air flow rate (H/L)	cfm	635/470
	Drive		Direct drive
Temperature control			Microprocessor thermostat for cooling and heating
Sound absorbing thermal insulation material			Foamed polystyrene / Foamed polyethylene
Air filter			Resin net (washable)
★4 Sound pressure level (reference data) (H/L)	dB(A)		47/41
Weight		lbs	31
Piping connections	Liquid pipes	in.	ϕ3/8 (flare connection)
	Gas pipes	in.	ϕ5/8 (flare connection)
	Drain pipe	in.	VP13 (external dia. 11/16, internal dia. 1/2)
Safety devices			Fuse
Refrigerant control			Electronic expansion valve
Connectable outdoor unit			R410A VRV series
Standard accessories			Operation manual, Installation manual, Installation panel, Paper pattern for installation, Insulation tape, Insulation tube, Clamps, Screws

Note:

- ★1. Nominal cooling capacities are based on the following conditions:
Return air temperature: 80°FDB, 67°FWB
Outdoor temperature: 95°FDB
Equivalent refrigerant piping length: 25 ft (horizontal)
- ★2. Nominal heating capacities are based on the following conditions:
Return air temperature: 70°FDB.
Outdoor temperature: 47°FDB, 43°FWB
Equivalent refrigerant piping length: 25 ft (horizontal)
- ★3. Capacities are net, including a deduction for cooling (an addition for heating) for indoor fan motor heat.
- ★4. Anechoic chamber conversion value, measured under JIS conditions. During actual operation, these values may be higher as a result of installation conditions.

C: 3D075572A

2. Dimensions

FXAQ07-12PVJU

Unit: in.

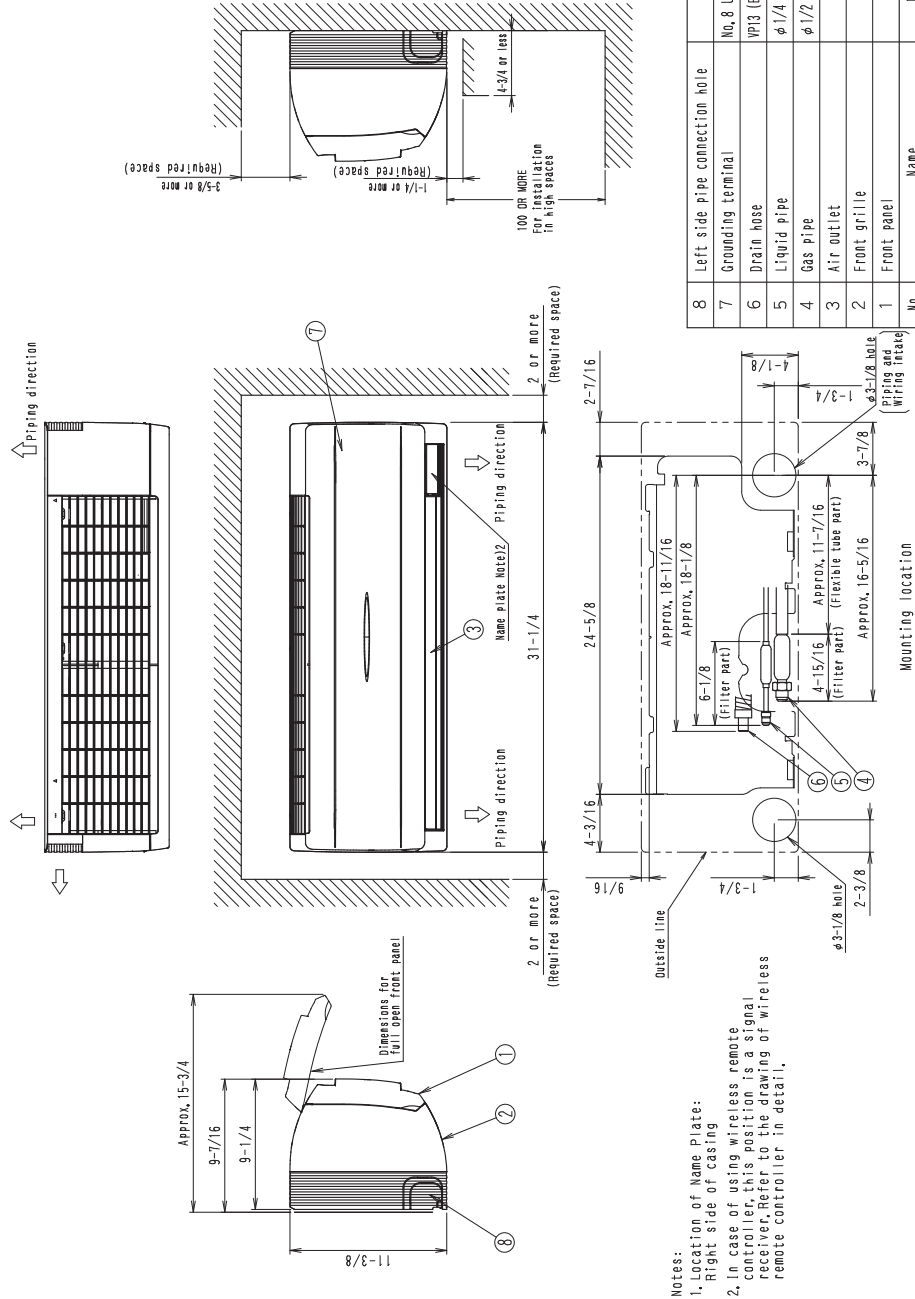

No.	Name	Description
8	Left side pipe connection hole	No. 8 UNC
7	Grounding terminal	WPS (External dia. φ11/16)
6	Drain hose	φ1/4 Flare connection
5	Liquid pipe	φ1/2 Flare connection
4	Gas pipe	
3	Air outlet	
2	Front grille	
1	Front panel	

3D075388A

FXAQ18PVJU

Unit: in.

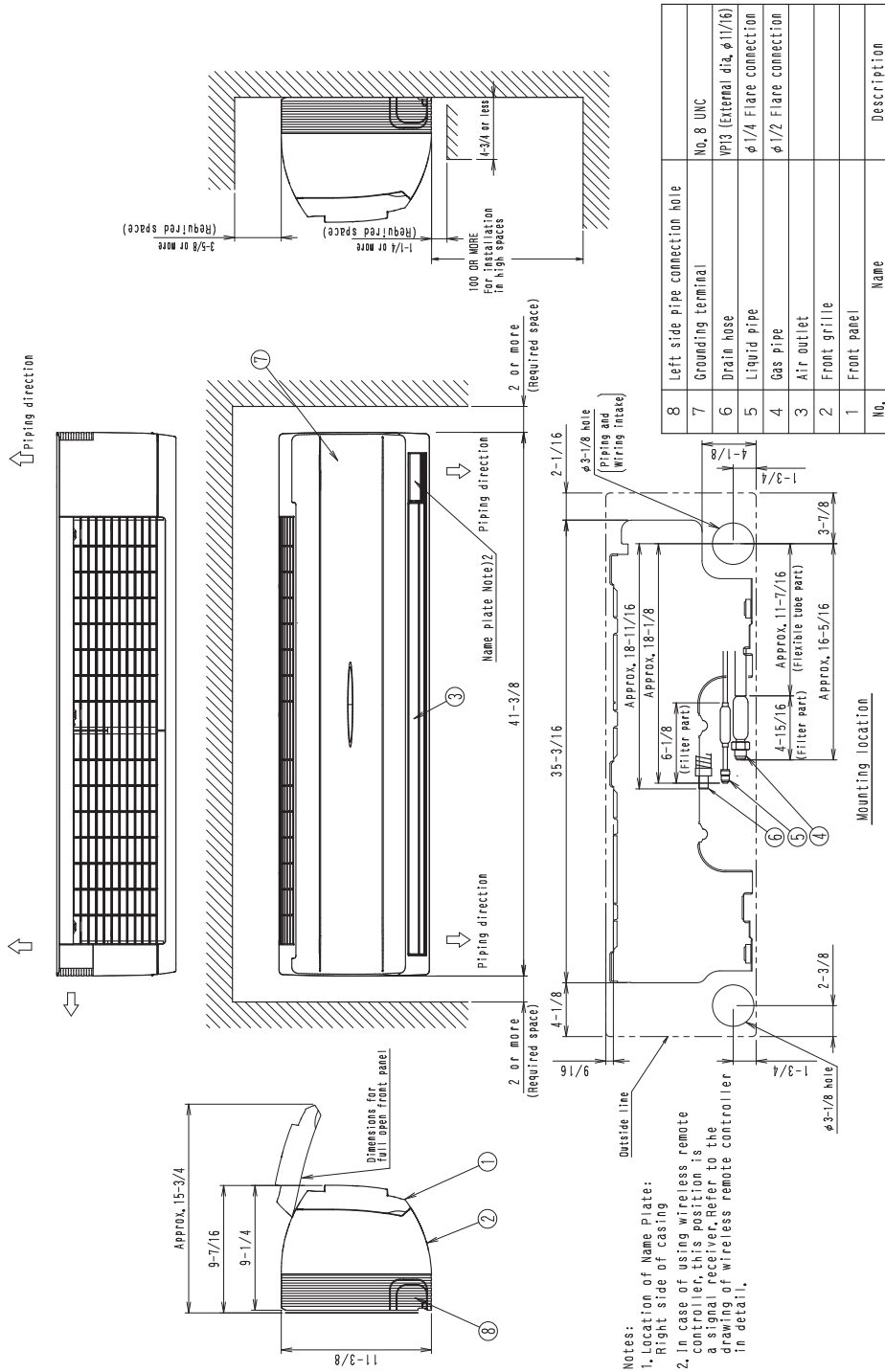

Notes:
 1. Location of Name Plate:
 Right side of casing
 2. In case of using wireless remote controller, this position is a signal receiver. Refer to the drawing of wireless remote controller in detail.

No.	Name	Description
8	Left side pipe connection hole	No. 8 UNC
7	Grounding terminal	WP13 (External dia. ϕ 11/16)
6	Drain hose	ϕ 1/4 Flare connection
5	Liquid pipe	ϕ 1/2 Flare connection
4	Gas pipe	
3	Air outlet	
2	Front grille	
1	Front panel	

3D075389A

FXAQ24PVJU

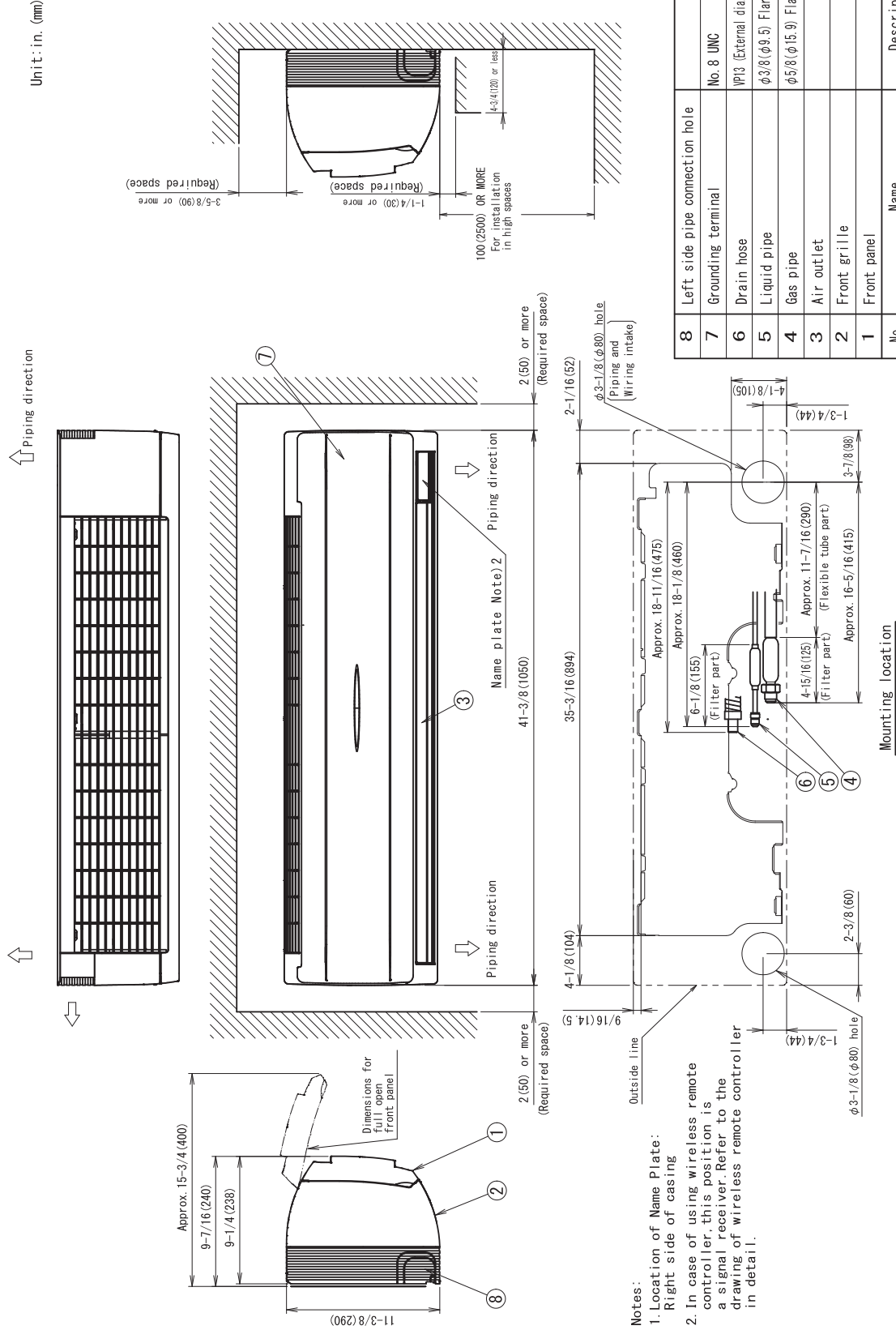

Notes:

1. Location of Name Plate: Right side of casing
2. In case of using wireless remote controller, this position is a signal receiver. Refer to the drawing of wireless remote controller in detail.

No.	Name	Description
8	Left side pipe connection hole	No. 8 UNC
7	Grounding terminal	No. 8 UNC
6	Drain hose	VP13 (External dia. φ11/16 (φ18))
5	Liquid pipe	φ3/8 (φ9.5) Flare connection
4	Gas pipe	φ5/8 (φ15.9) Flare connection
3	Air outlet	
2	Front grille	
1	Front panel	

3D075390B

3. Piping Diagrams

FXAQ07-24PVJU

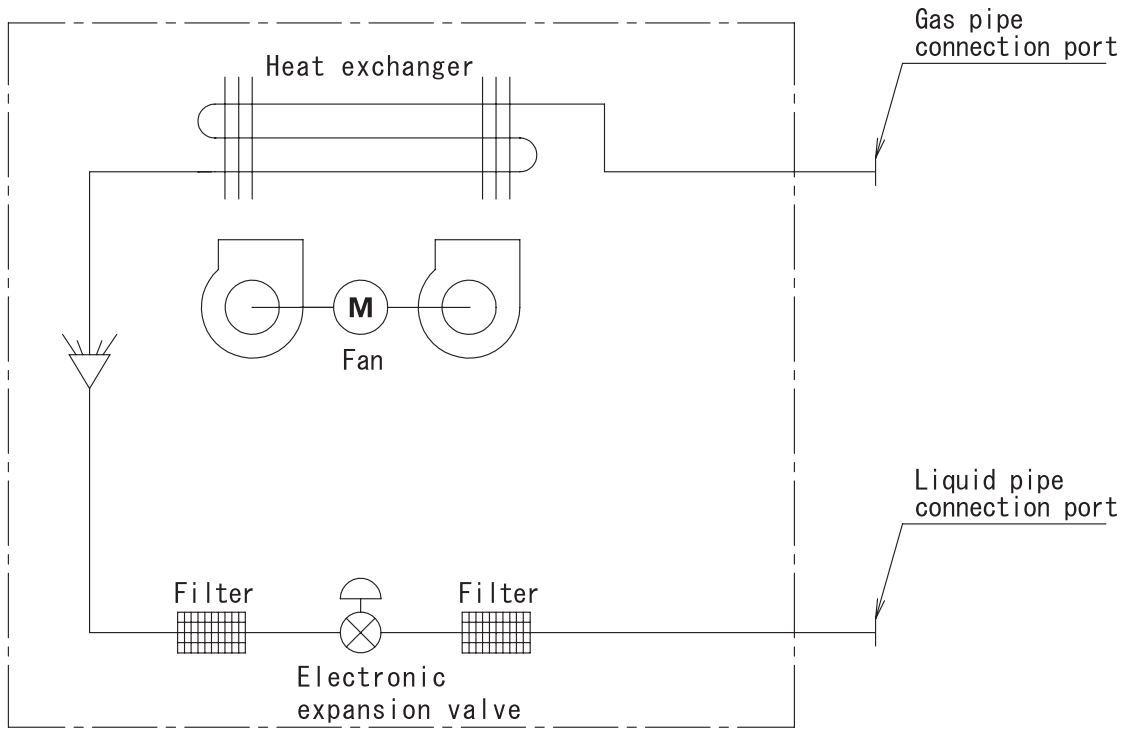

C: 4D034245R

Unit: in. (mm)

Model	Gas	Liquid
FXAQ07PVJU FXAQ09PVJU FXAQ12PVJU FXAQ18PVJU	ϕ 1/2 (ϕ 12.7)	ϕ 1/4 (ϕ 6.4)
FXAQ24PVJU	ϕ 5/8 (ϕ 15.9)	ϕ 3/8 (ϕ 9.5)

4. Wiring Diagrams

FXAQ07-24PVJU

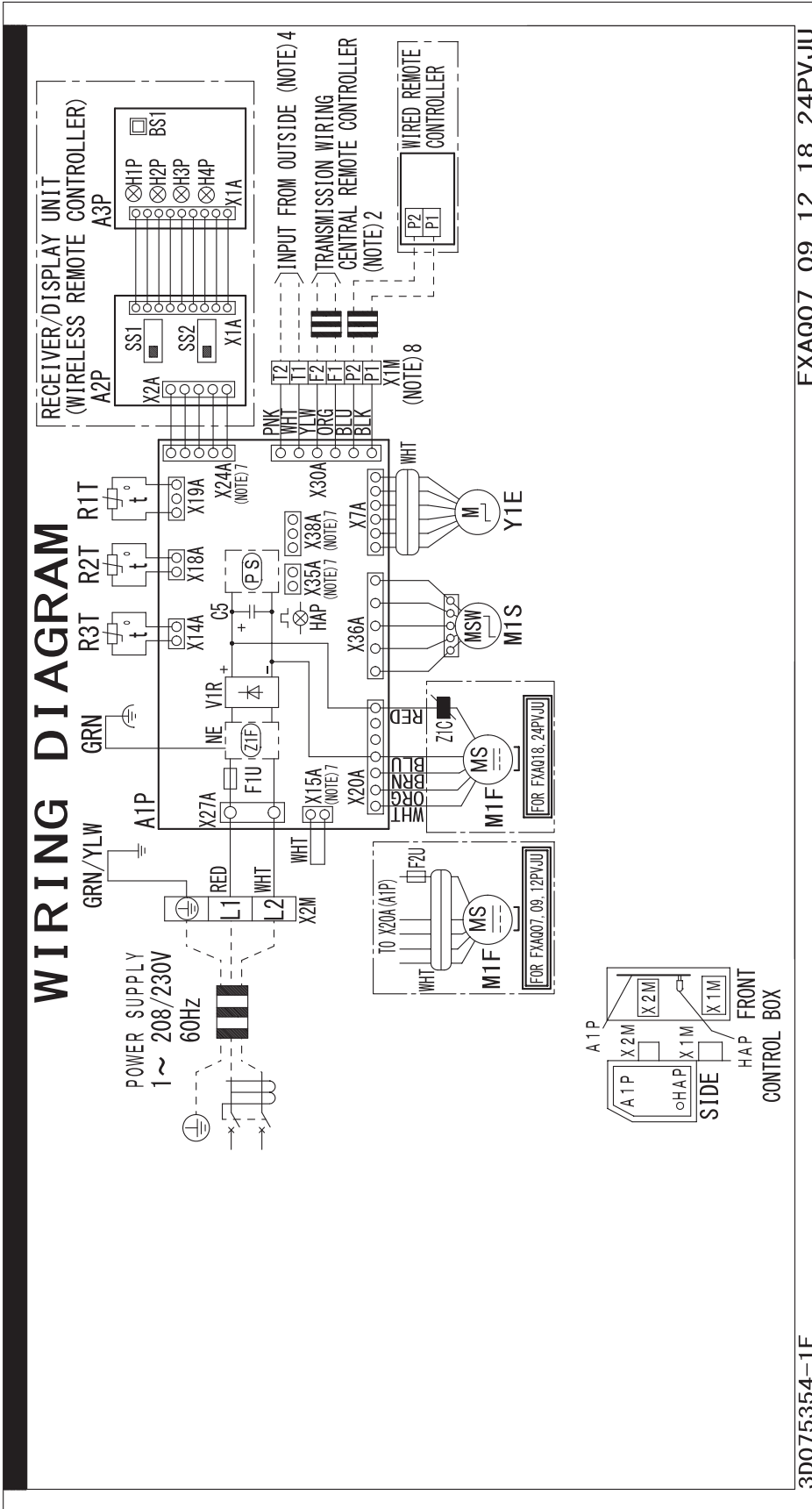

- (NOTES)
1. □ : TERMINAL, ■ : FIELD WIRING, □ : CONNECTOR, D— : CONNECTOR, ⊕ : PROTECTIVE GROUND (SCREW), ⊕ : NOISELESS GROUND, ⊕ : SHORT CIRCUIT CONNECTOR
 2. IN CASE USING CENTRAL REMOTE CONTROLLER, CONNECT IT TO THE UNIT IN ACCORDANCE WITH THE ATTACHED INSTALLATION MANUAL.
 3. SYMBOLS SHOW AS FOLLOWS: RED: WHT; WHITE: GRN; GREEN: PNK; PINK: YLW; YELLOW: BLK; BLACK: ORG; ORANGE: BRN; BROWN: BLU; BLUE
 4. WHEN CONNECTING THE INPUT WIRES FROM OUTSIDE, FORCED OFF OR ON/OFF CONTROL OPERATION CAN BE SELECTED BY REMOTE CONTROLLER. IN DETAILS, REFER TO THE INSTALLATION MANUAL ATTACHED TO THE UNIT.
 5. REMOTE CONTROLLER MODEL VARIES ACCORDING TO THE COMBINATION SYSTEM, CONFIRM ENGINEERING DATA AND CATALOGS, ETC. BEFORE CONNECTING.
 6. CONFIRM THE METHOD OF SETTING THE SELECTOR SWITCH (SS1, SS2) OF WIRELESS REMOTE CONTROLLER BY INSTALLATION MANUAL AND ENGINEERING DATA, ETC.
 7. X15A, X24A, X35A AND X38A ARE CONNECTED WHEN THE OPTIONAL ACCESSORIES ARE BEING USED.
 8. CLASS 2 WIRE

C: 3D075354F

FXAQ07-24PVJU

INDOOR UNIT	
A1P	PRINTED CIRCUIT BOARD
C5	CAPACITOR
F1U	FUSE (T, 3.15 AH, 250 V)
F2U	FUSE
HAP	FLASHING LAMP (SERVICE MONITOR GREEN)
M1F	MOTOR (INDOOR FAN)
M1S	MOTOR (SWING FLAP)
R1T	THERMISTOR (AIR)
R2T	THERMISTOR (COIL LIQUID PIPE)
R3T	THERMISTOR (COIL GAS PIPE)
V1R	DIODE BRIDGE
X1M	TERMINAL BLOCK (CONTROL)
X2M	TERMINAL BLOCK (POWER)
Y1E	ELECTRONIC EXPANSION VALVE
Z1C	FERRITE CORE
Z1F	NOISE FILTER
PS	SWITCHING POWER SUPPLY
RECEIVER/DISPLAY UNIT (ATTACHED TO WIRELESS REMOTE CONTROLLER)	
A2P	PRINTED CIRCUIT BOARD
A3P	PRINTED CIRCUIT BOARD
BS1	PUSH BUTTON SWITCH (ON/OFF)
H1P	PILOT LAMP (ON-RED)
H2P	PILOT LAMP (TIMER-GREEN)
H3P	PILOT LAMP (FILTER SIGN-RED)
H4P	PILOT LAMP (DEFROST-ORANGE)
SS1	SELECTOR SWITCH (MAIN/SUB)
SS2	SELECTOR SWITCH (WIRELESS ADDRESS SET)
CONNECTOR FOR OPTIONAL PARTS	
X15A	CONNECTOR (FLOAT SWITCH)
X24A	CONNECTOR (WIRELESS REMOTE CONTROLLER)
X35A	CONNECTOR (GROUP CONTROL ADAPTOR)
X38A	CONNECTOR (ADAPTOR FOR MULTI TENANT)

C: 3D075354F

5. Electric Characteristics

FXAQ07-24PVJU

Model	Power supply				IFM		Input (W)		
	Hz	Volts	Voltage range	MCA	MOP	kW	FLA	Cooling	Heating
FXAQ07PVJU	60	208/230 V	Max. 253 V Min. 187 V	0.4	15	0.040	0.3	19	29
FXAQ09PVJU				0.4	15	0.040	0.3	28	34
FXAQ12PVJU				0.4	15	0.040	0.3	30	35
FXAQ18PVJU				0.5	15	0.043	0.4	33	39
FXAQ24PVJU				0.6	15	0.043	0.5	50	60

Symbol:

MCA: Minimum Circuit Ampacity (A)
 MOP: Maximum Overcurrent Protective Device (A)
 kW: Fan Motor Rated Output (kW)
 FLA: Full Load Ampacity (A)
 IFM: Indoor Fan Motor

Note:

1. Voltage range
 Units are suitable for use on electrical systems where voltage supplied to unit terminals is not below or above listed range limits.
2. Maximum allowable voltage unbalance between phases is 2%.
3. MCA/MOP
 $MCA = 1.25 \times FLA$
 $MOP \leq 4 \times FLA$
 (Next lower standard fuse rating. Minimum 15 A)
4. Select wire size based on the value of MCA.
5. Either a fuse or a circuit breaker is acceptable.

C: 4D075550

6. Safety Devices Setting

Model		FXAQ07PVJU	FXAQ09PVJU	FXAQ12PVJU	FXAQ18PVJU	FXAQ24PVJU
PC board fuse		250 V, 3.15 A	250 V, 3.15 A	250 V, 3.15 A	250 V, 3.15 A	250 V, 3.15 A
Fan motor thermal fuse	°F	—	—	—	—	—
Fan motor thermal protector	°F	—	—	—	—	—

C: 4D047085D

7. Capacity Tables

7.1 Cooling Capacity at Te: 43°F (6°C)

Model	Indoor air temp. °FWB (°CWB) (Te: 43°F (6°C))											
	61 (16.1)		64 (17.8)		67 (19.4)		70 (21.1)		72 (22.2)		75 (23.9)	
	TC	SHC	TC	SHC	TC	SHC	TC	SHC	TC	SHC	TC	SHC
	MBH	MBH	MBH	MBH	MBH	MBH	MBH	MBH	MBH	MBH	MBH	MBH
FXAQ07PVJU	5.9	5.6	6.7	6.1	7.5	6.4	8.0	6.5	8.1	6.3	8.2	6.0
FXAQ09PVJU	7.5	6.5	8.5	7.2	9.5	7.3	10.1	7.4	10.2	7.4	10.4	7.0
FXAQ12PVJU	9.5	7.9	10.7	8.3	12.0	8.9	12.7	8.9	12.9	8.8	13.1	8.5
FXAQ18PVJU	14.2	11.7	16.1	12.7	18.0	13.7	19.1	13.6	19.3	13.3	19.7	12.4
FXAQ24PVJU	18.9	15.3	21.5	16.5	24.0	18.0	25.5	17.8	25.8	17.6	26.3	16.2

TC: Total capacity: MBH
 SHC: Sensible heat capacity: MBH

Note:

1. These capacity tables can be used when selecting a **VRV** indoor unit. The actual capacity of the **VRV** system depends on factors such as the selected model of outdoor units, outdoor air temperature and piping length. Please confirm that the corrected capacity of the **VRV** system satisfies the required heat load.
2. shows rated condition.

7.2 Heating Capacity

Model	Indoor air temp. °FDB (°CDB) (Tc: 115°F (46°C))											
	62 (16.7)		65 (18.3)		68 (20.0)		70 (21.1)		72 (22.2)		75 (23.9)	
	TC	TC	TC	TC	TC	TC	TC	TC	TC	TC	TC	
	MBH	MBH	MBH	MBH	MBH	MBH	MBH	MBH	MBH	MBH	MBH	
FXAQ07PVJU	9.3	9.2	8.7	8.5	8.1	7.7						
FXAQ09PVJU	11.8	11.7	11.1	10.5	10.3	9.7						
FXAQ12PVJU	14.9	14.7	14.0	13.5	13.0	12.3						
FXAQ18PVJU	22.3	22.1	21.0	20.0	19.5	18.4						
FXAQ24PVJU	29.2	29.0	27.5	26.5	25.5	24.0						

TC: Total capacity: MBH

Note:

1. These capacity tables can be used when selecting a **VRV** indoor unit. The actual capacity of the **VRV** system depends on factors such as the selected model of outdoor units, outdoor air temperature and piping length. Please confirm that the corrected capacity of the **VRV** system satisfies the required heat load.
2. shows rated condition.

7.3 Correction Factor for Cooling Capacity at Te: 48°F (9°C)

Refer to the correction factor table below when a mini-split indoor unit is connected to a **VRV** Heat Pump system using a Branch Port box.

Model	Indoor air temp. °FWB (°CWB) (Te: 48°F (9°C))													
	57 (13.9)		61 (16.1)		64 (17.8)		67 (19.4)		70 (21.1)		72 (22.2)		75 (23.9)	
	TC	SHF	TC	SHF	TC	SHF	TC	SHF	TC	SHF	TC	SHF	TC	SHF
	TC	SHF	TC	SHF	TC	SHF	TC	SHF	TC	SHF	TC	SHF	TC	SHF
FXAQ07PVJU	0.69	1.13	0.69	1.19	0.74	1.14	0.77	1.11	0.80	1.08	0.82	1.06	0.83	1.05
FXAQ09PVJU	0.69	1.12	0.69	1.19	0.74	1.15	0.77	1.11	0.80	1.07	0.82	1.06	0.83	1.05
FXAQ12PVJU	0.70	1.10	0.69	1.19	0.73	1.15	0.77	1.09	0.80	1.07	0.82	1.06	0.83	1.05
FXAQ18PVJU	0.69	1.12	0.69	1.18	0.75	1.13	0.78	1.09	0.82	1.06	0.83	1.05	0.85	1.05
FXAQ24PVJU	0.69	1.10	0.69	1.18	0.75	1.13	0.79	1.09	0.82	1.06	0.84	1.05	0.85	1.05

TC: Total capacity
 SHF: Sensible heat factor

8. Air Velocity and Temperature Distributions (Reference Data)

8.1 Cooling Mode

FXAQ07PVJU <Cooling mode>

AIRFLOW DISTRIBUTIONS

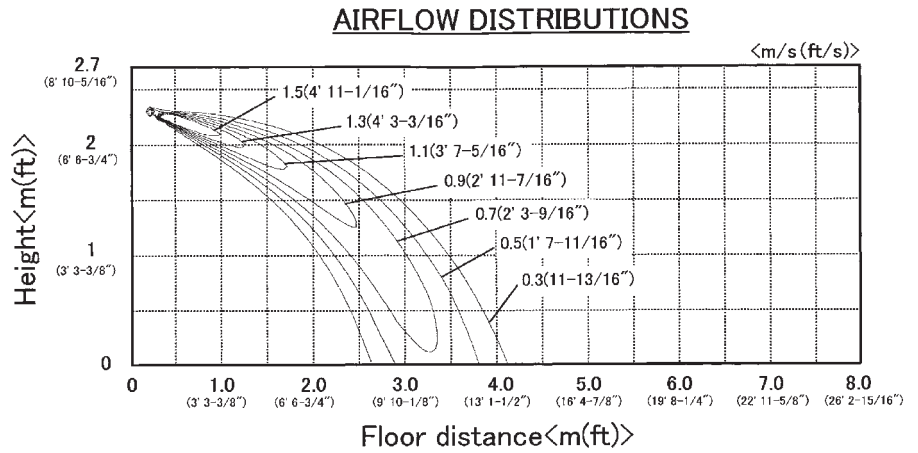

TEMPERATURE DISTRIBUTIONS

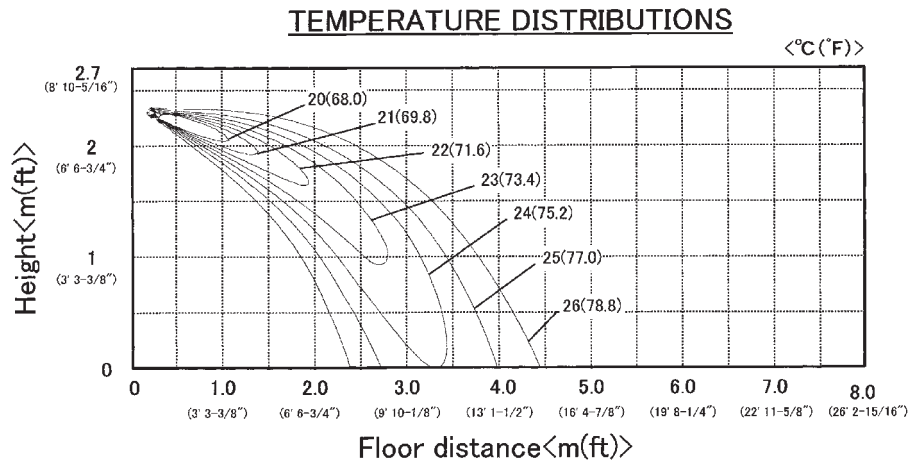

C: 3D053942

FXAQ09PVJU <Cooling mode>

AIRFLOW DISTRIBUTIONS

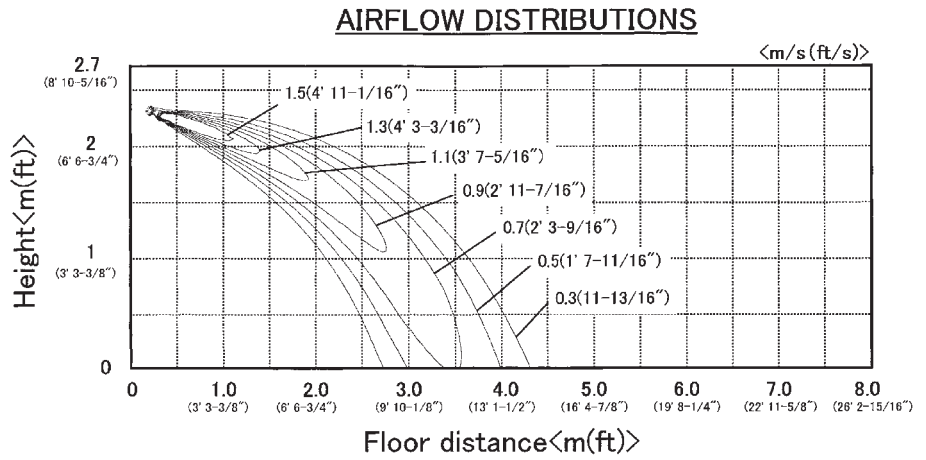

TEMPERATURE DISTRIBUTIONS

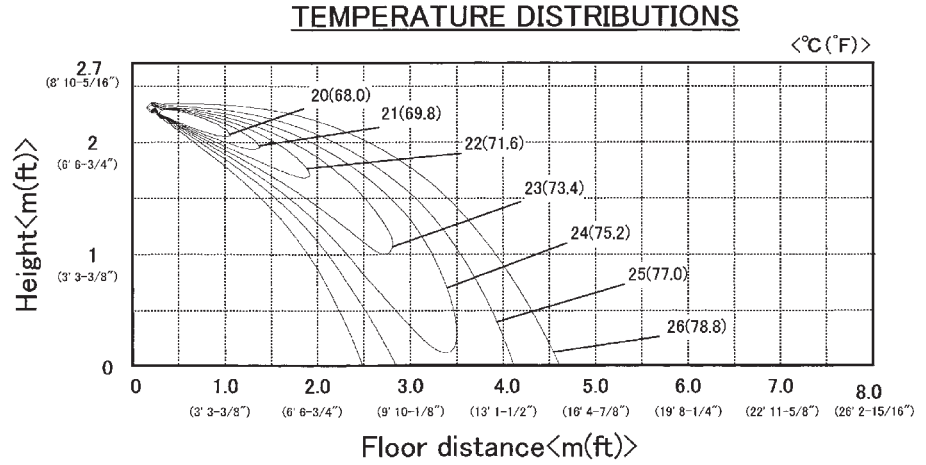

C: 3D053943

FXAQ12PVJU <Cooling mode>

AIRFLOW DISTRIBUTIONS

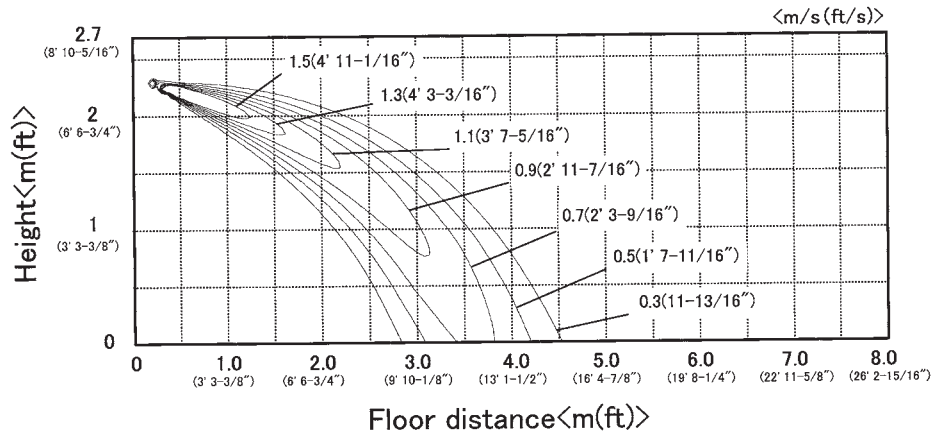

TEMPERATURE DISTRIBUTIONS

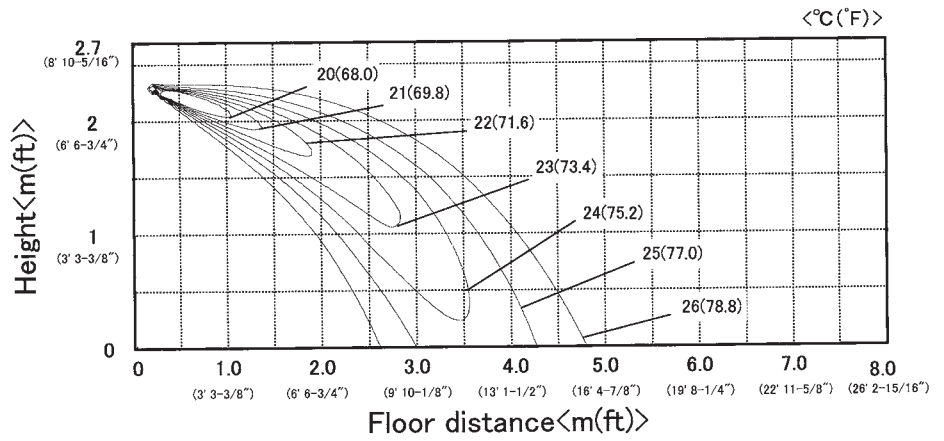

C: 3D052935

FXAQ18PVJU <Cooling mode>

AIRFLOW DISTRIBUTIONS

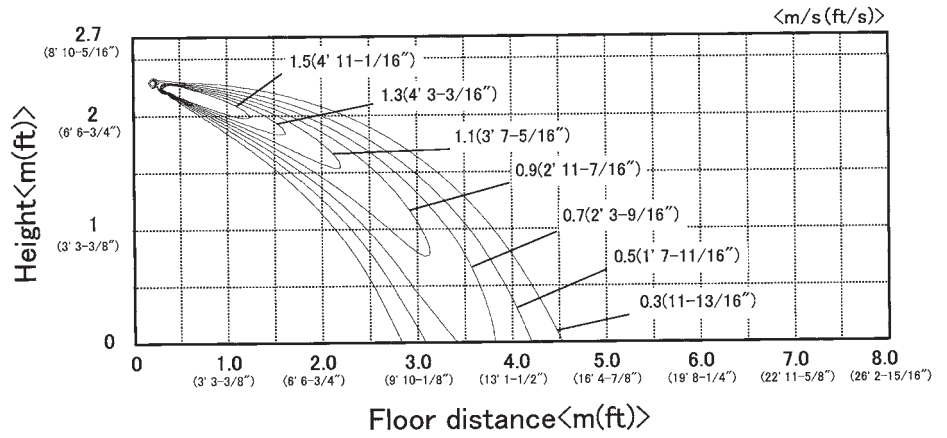

TEMPERATURE DISTRIBUTIONS

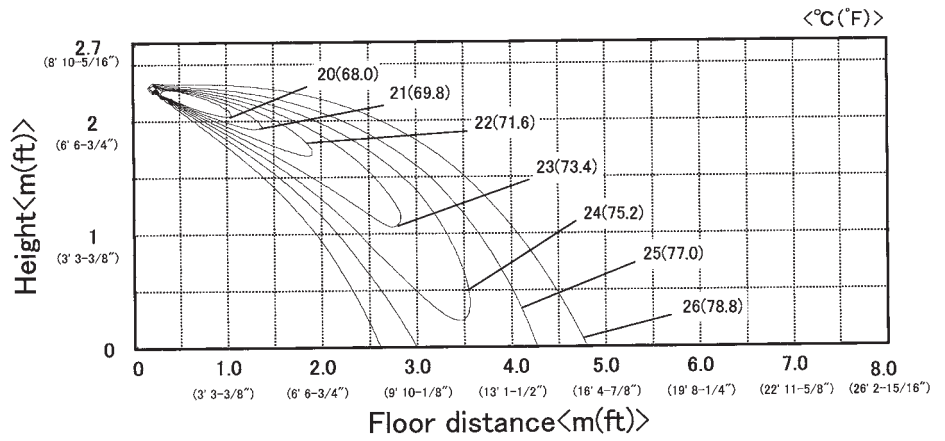

C: 3D052936

FXAQ24PVJU <Cooling mode>

AIRFLOW DISTRIBUTIONS

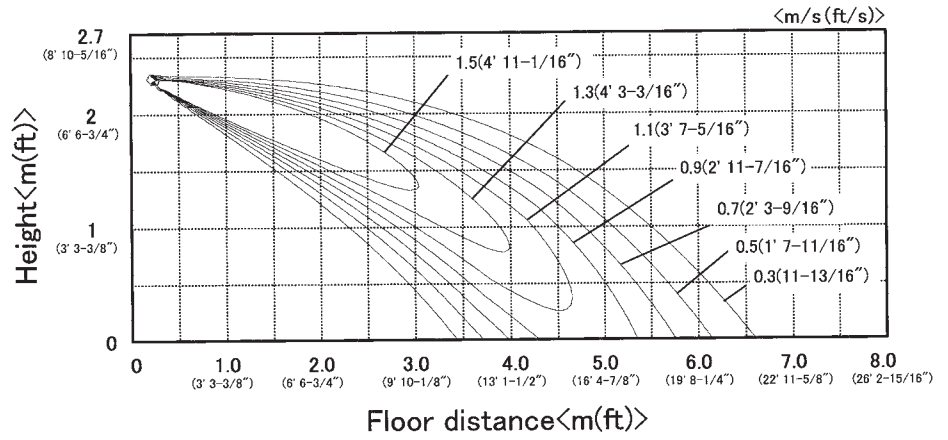

TEMPERATURE DISTRIBUTIONS

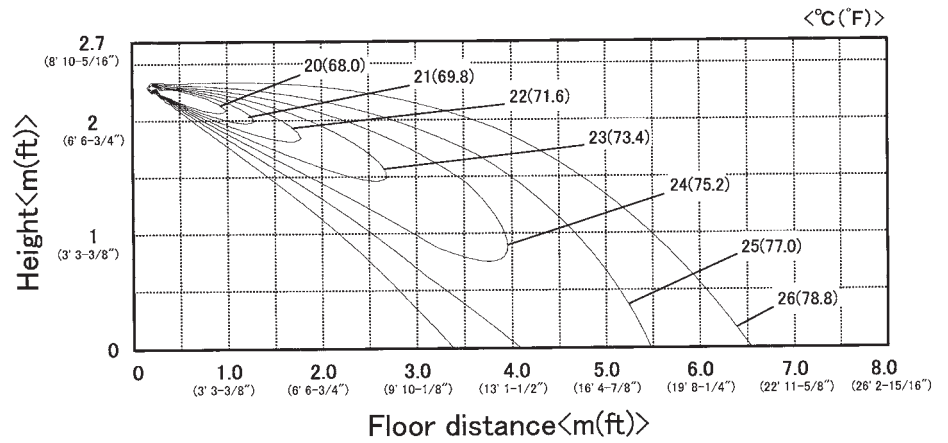

C: 3D052937

8.2 Heating Mode
FXAQ07PVJU <Heating mode>

AIRFLOW DISTRIBUTIONS

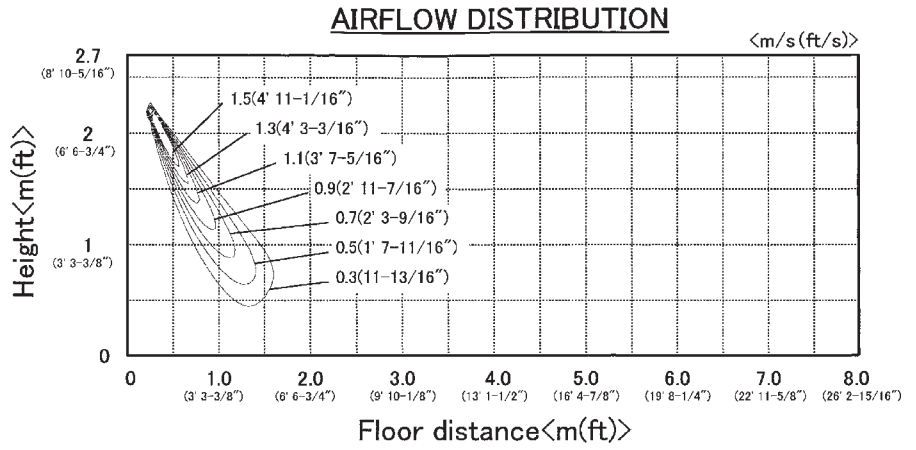

TEMPERATURE DISTRIBUTIONS

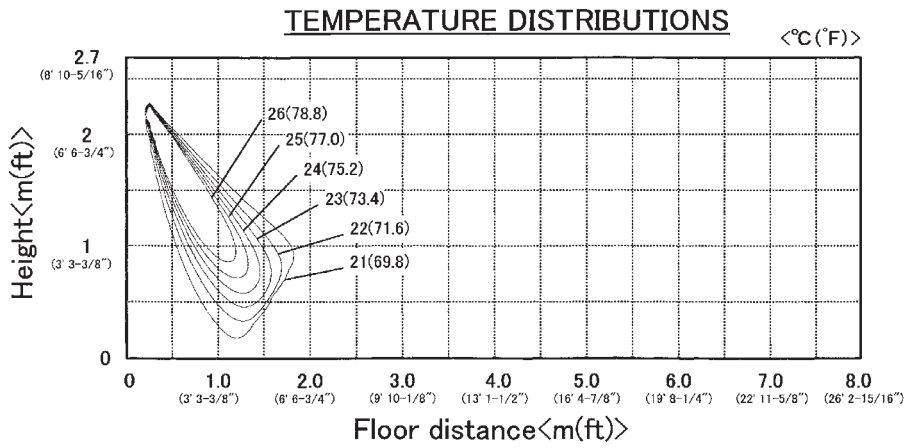

C: 3D053942

FXAQ09PVJU <Heating mode>

AIRFLOW DISTRIBUTIONS

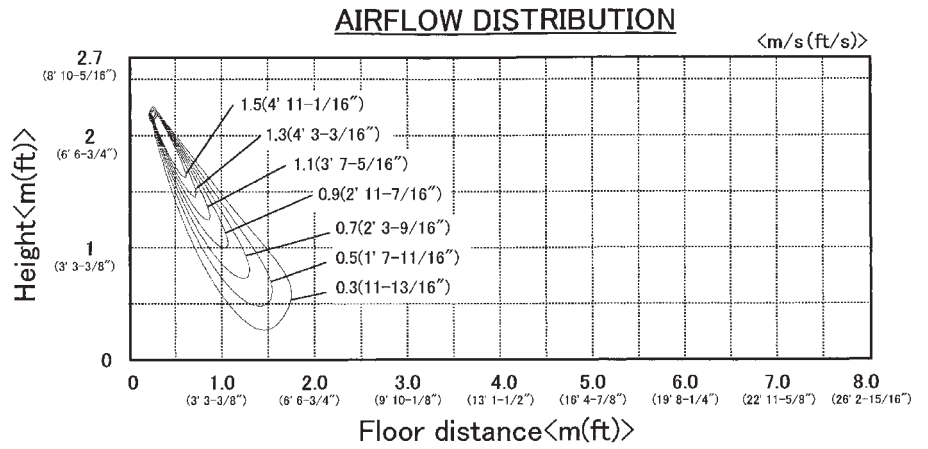

TEMPERATURE DISTRIBUTIONS

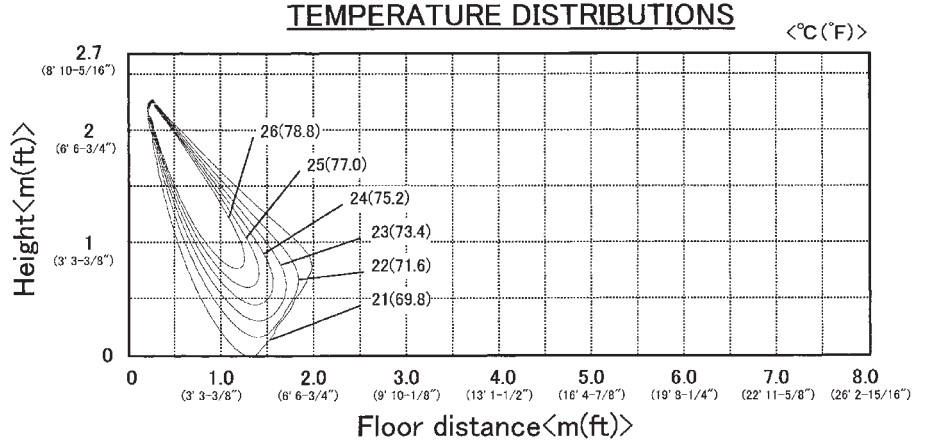

C: 3D053943

FXAQ12PVJU <Heating mode>

AIRFLOW DISTRIBUTIONS

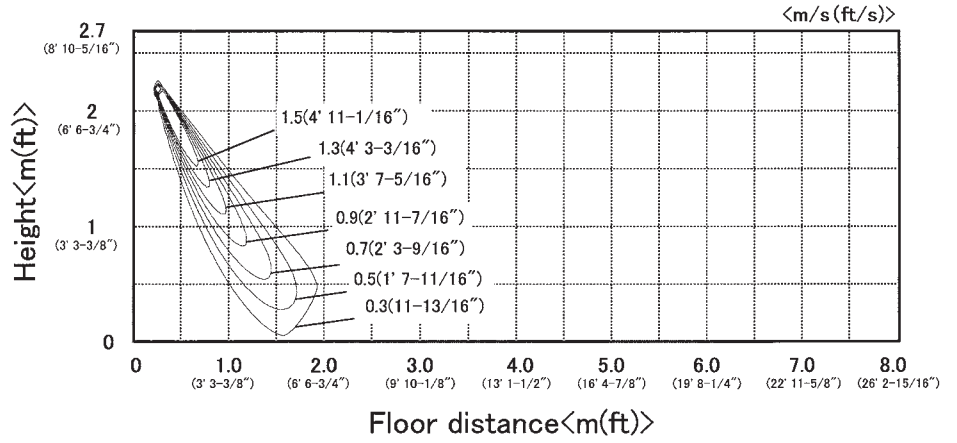

TEMPERATURE DISTRIBUTIONS

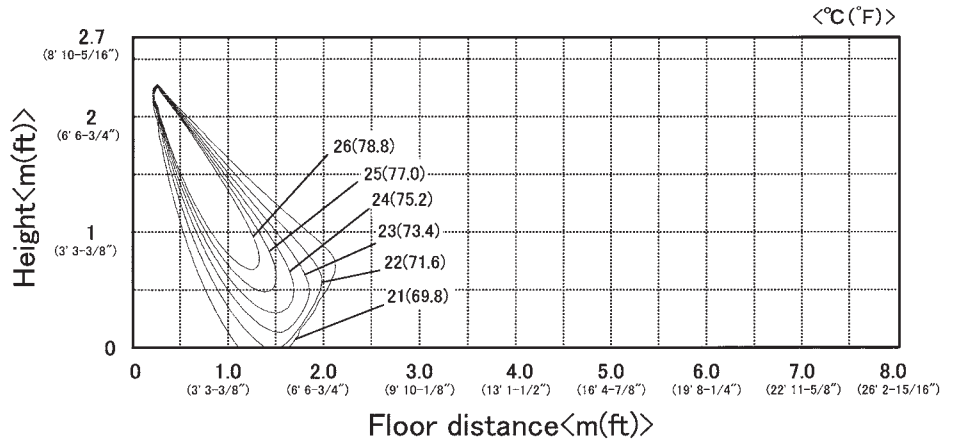

C: 3D052935

FXAQ18PVJU <Heating mode>

AIRFLOW DISTRIBUTIONS

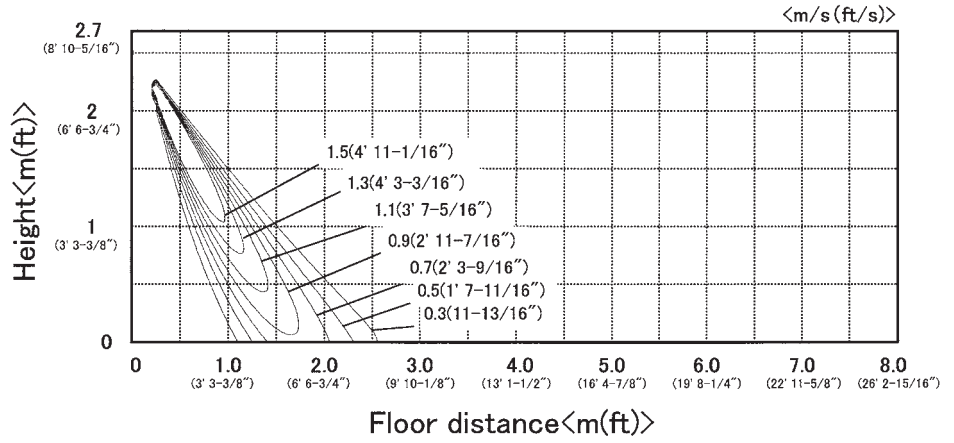

TEMPERATURE DISTRIBUTIONS

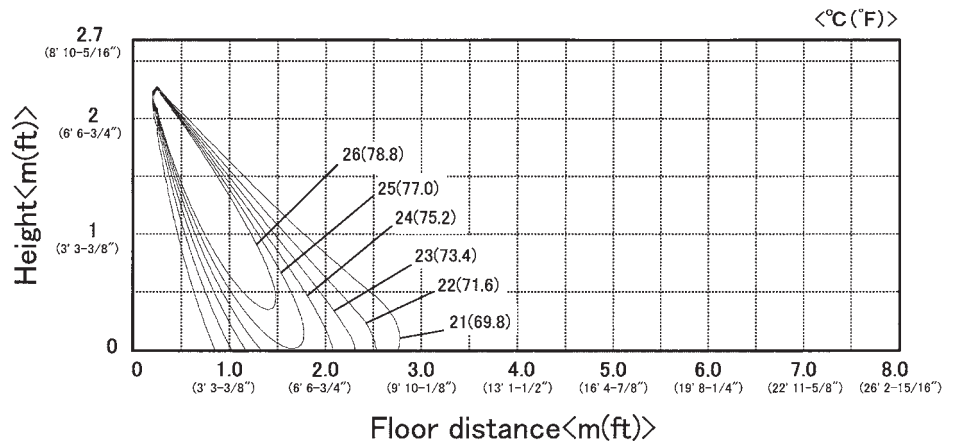

C: 3D052936

FXAQ24PVJU <Heating mode>

AIRFLOW DISTRIBUTIONS

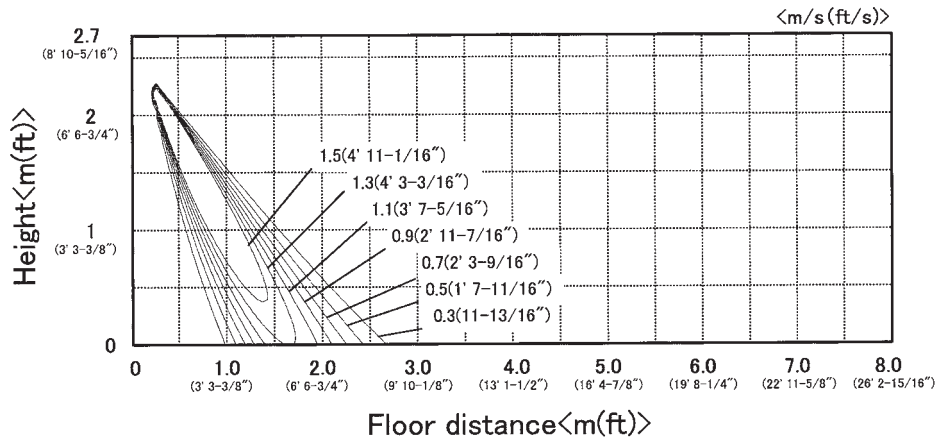

TEMPERATURE DISTRIBUTIONS

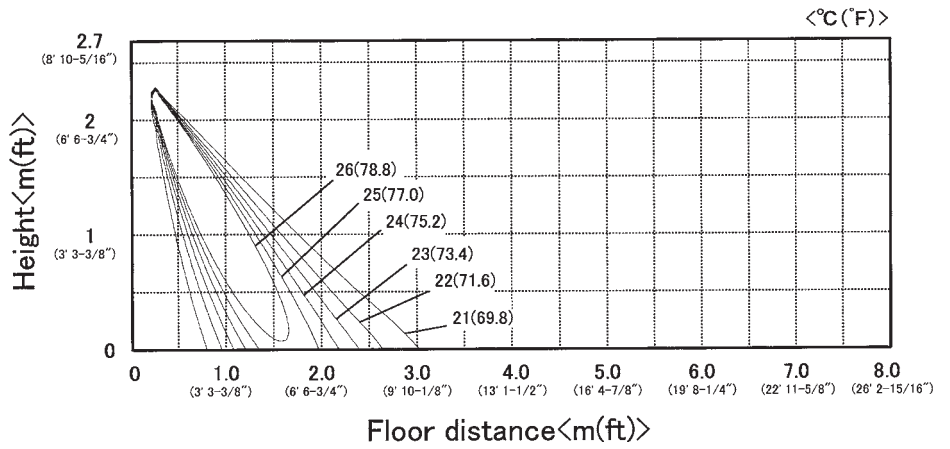

C: 3D052937

9. Sound Levels (Reference Data)

FXAQ07PVJU

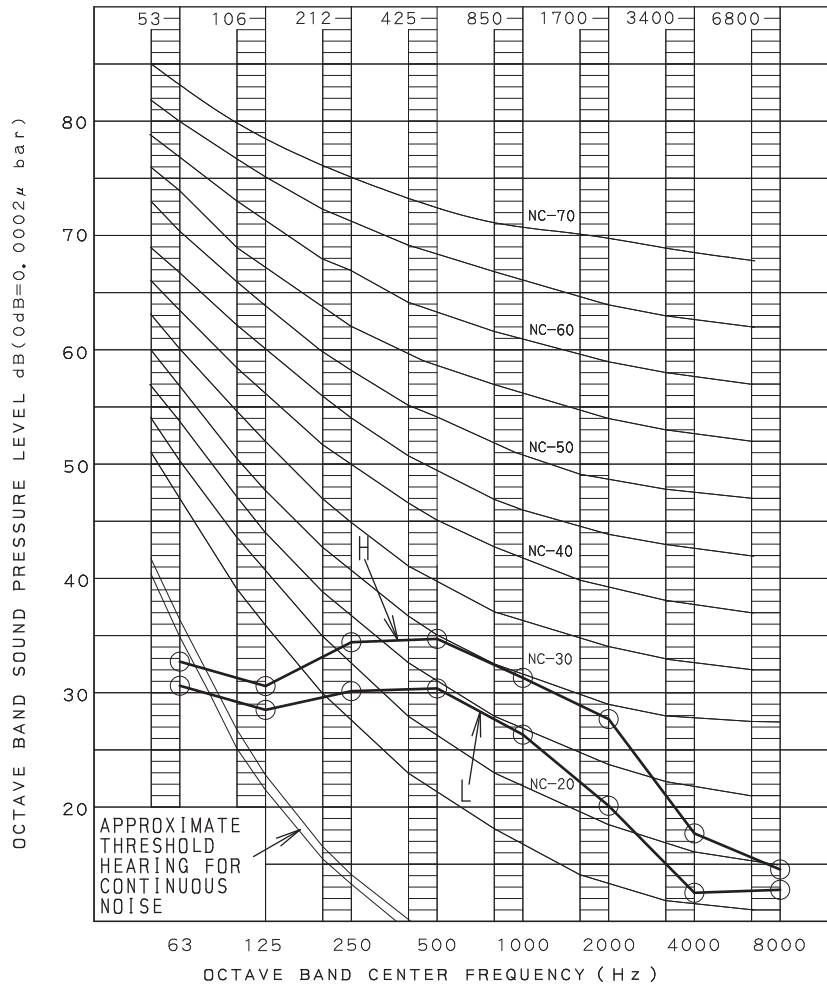

OVER ALL (dB)

SCALE	M O D E	
	H	L
A	36.0	31.0

(B. G. N IS ALREADY RECTIFIED)

MEASURING PLACE

MEASURE IN ANECHOIC ROOM

OPERATING CONDITIONS

POWER SOURCE 208/230V, 60Hz

STANDARD CONDITION (JIS)

LOCATION OF MICROPHONE

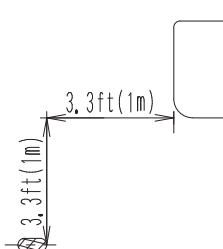

MICROPHONE

NOTE: Operation noise differs with operation and ambient conditions.

FXAQ09PVJU

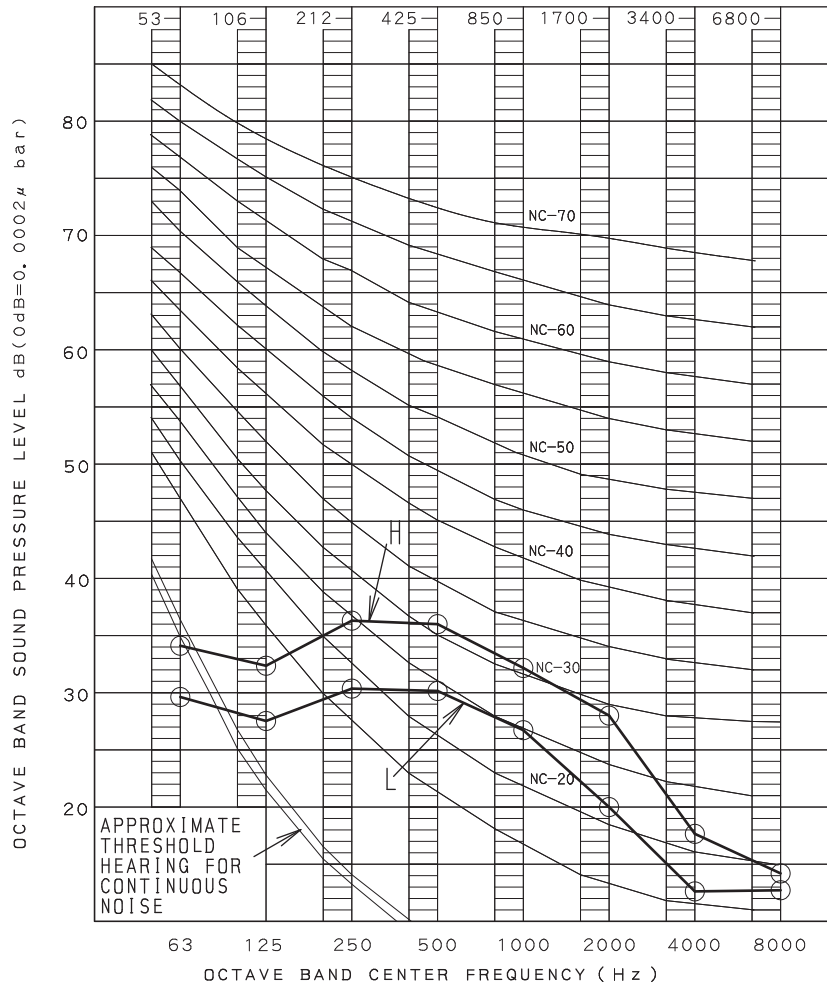

OVER ALL (dB)

SCALE	M O D E	
	H	L
A	37.0	31.0

(B. G. N IS ALREADY RECTIFIED)

MEASURING PLACE

MEASURE IN ANECHOIC ROOM

OPERATING CONDITIONS

POWER SOURCE 208/230V, 60Hz

STANDARD CONDITION (JIS)

LOCATION OF MICROPHONE

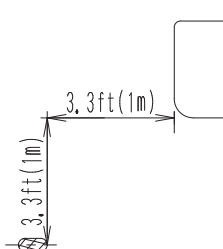

MICROPHONE

NOTE: Operation noise differs with operation and ambient conditions.

FXAQ12PVJU

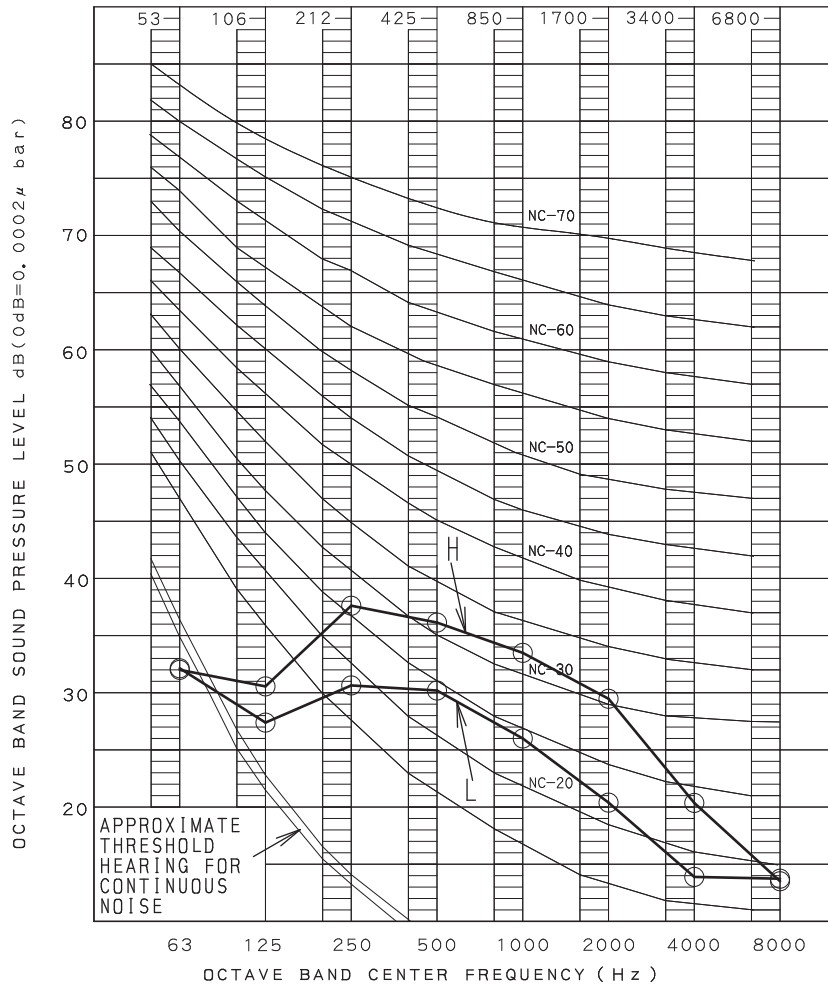

OVER ALL (dB)

SCALE	M O D E	
	H	L
A	38.0	31.0

(B, G, N IS ALREADY RECTIFIED)

MEASURING PLACE

MEASURE IN ANECHOIC ROOM

OPERATING CONDITIONS

POWER SOURCE 208/230V, 60Hz

STANDARD CONDITION (JIS)

LOCATION OF MICROPHONE

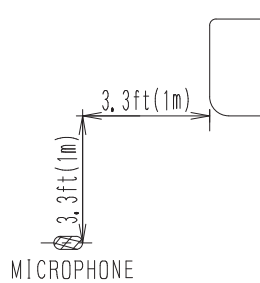

MICROPHONE

NOTE: Operation noise differs with operation and ambient conditions.

FXAQ18PVJU

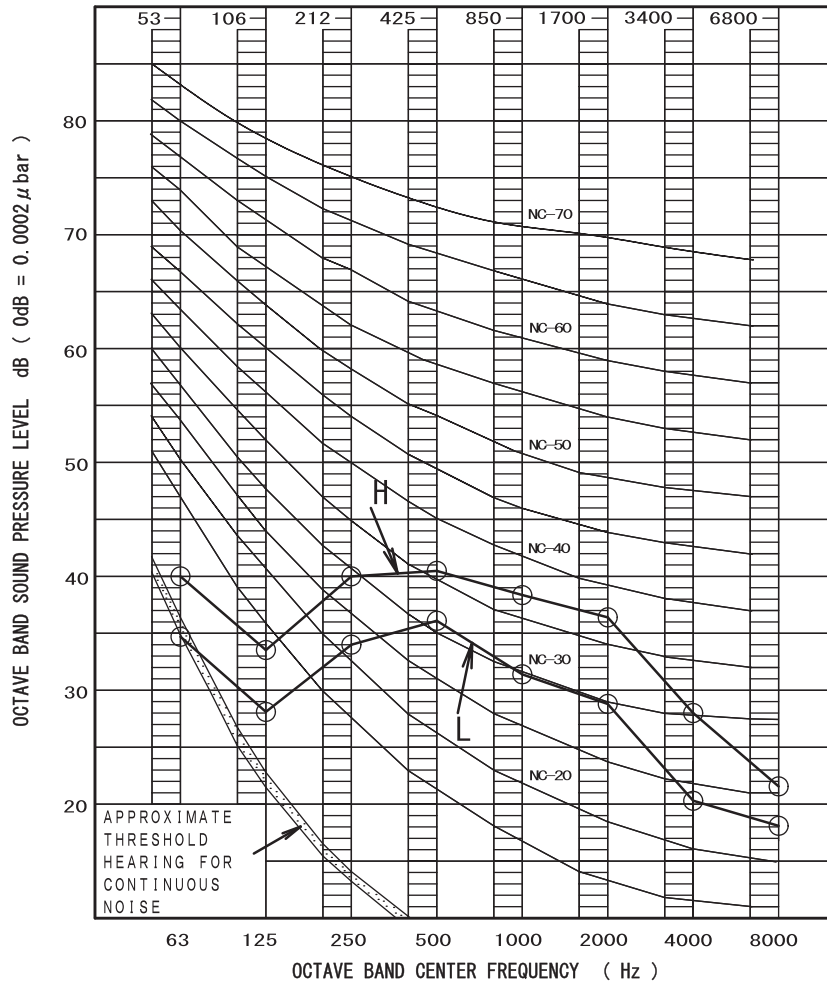

OVER ALL (dB)

SCALE	M O D E	
	H	L
A	43.0	37.0

(B. G. N IS ALREADY RECTIFIED)

MEASURING PLACE

MEASURE IN ANECHOIC ROOM

OPERATING CONDITIONS

POWER SOURCE 208/230V, 60Hz

STANDARD CONDITION (JIS)

LOCATION OF MICROPHONE

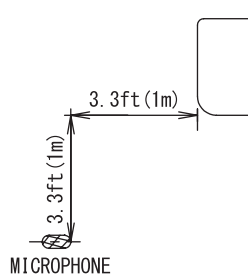

NOTE: Operation noise differs with operation and ambient conditions.

FXAQ24PVJU

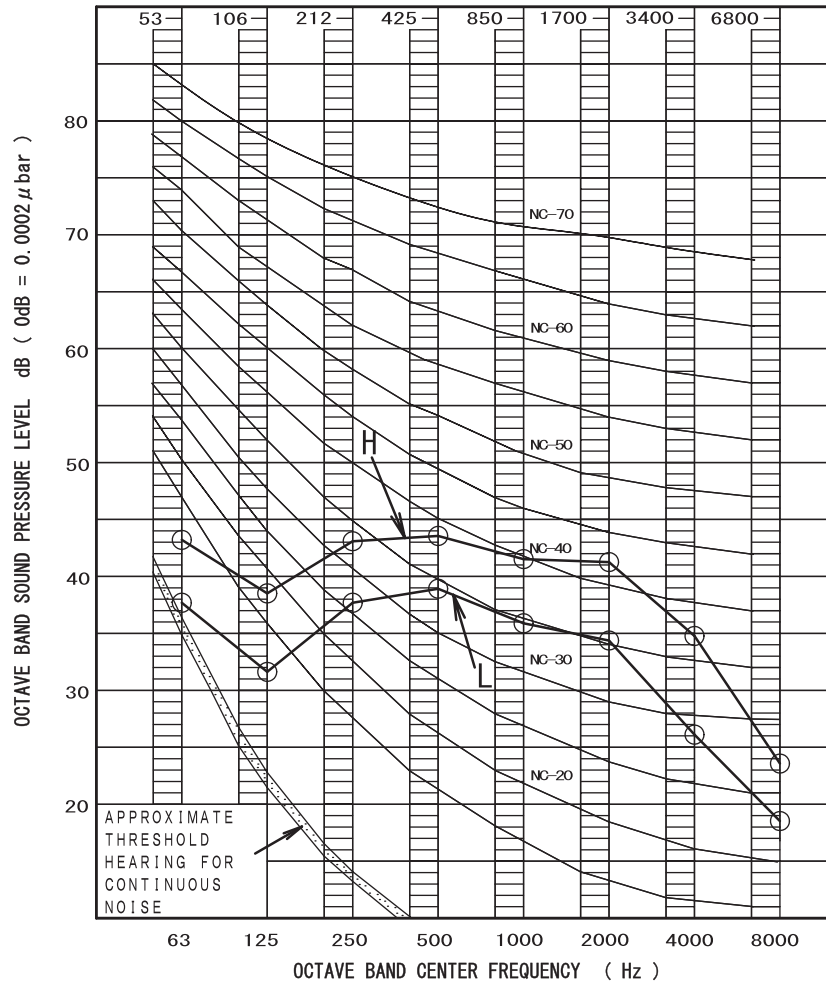

OVER ALL (dB)

SCALE	M O D E	
	H	L
A	47.0	41.0

(B. G. N IS ALREADY RECTIFIED)

OPERATING CONDITIONS

POWER SOURCE 208/230V, 60Hz

STANDARD CONDITION (JIS)

LOCATION OF MICROPHONE

MEASURING PLACE

MEASURE IN ANECHOIC ROOM

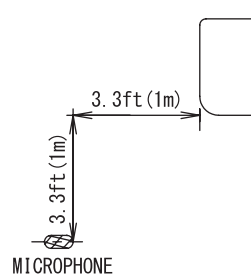

NOTE: Operation noise differs with operation and ambient conditions.



Warning ● Ask a qualified installer or contractor to install this product. Do not try to install the product yourself.



Improper installation can result in water or refrigerant leakage, electrical shock, fire or explosion.

- Use only those parts and accessories supplied or specified by Daikin. Ask a qualified installer or contractor to install those parts and accessories. Use of unauthorised parts and accessories or improper installation of parts and accessories can result in water or refrigerant leakage, electrical shock, fire or explosion.
- Read the user's manual carefully before using this product. The user's manual provides important safety instructions and warnings. Be sure to follow these instructions and warnings.

If you have any inquiries, please contact your local importer, distributor and/or retailer.

Cautions on product corrosion

1. Air conditioners should not be installed in areas where corrosive gases, such as acid gas or alkaline gas, are produced.
2. If the outdoor unit is to be installed close to the sea shore, direct exposure to the sea breeze should be avoided. If you need to install the outdoor unit close to the sea shore, contact your local distributor.